

# OPENING SYSTEMS FOR LIFT UP AND DROP DOWN DOORS

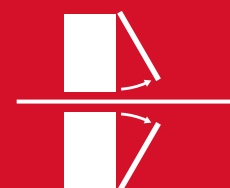

## Table of contents

KRABY SYSTEM LIFT UP	8.1
KRABY SYSTEM DROP DOWN	8.6
KRABY BRACKETS	8.13
KRABY ADAPTERS FOR ALUMINIUM FRAME DOOR	8.15
KRABY FOR WRITING DESK	8.18
COMPACT SYSTEM LIFT UP	8.23
COMPACT SYSTEM DROP DOWN	8.28
COMPACT BRACKETS	8.35
COMPACT ADAPTERS FOR ALUMINIUM FRAME DOOR	8.37
K12 SYSTEM LIFT UP	8.40
K12 SYSTEM ADJ LIFT UP	8.41
K12 SYSTEM DROP DOWN	8.46
K12 SYSTEM ADJ DROP DOWN	8.47
K12 SYSTEM & K12 SYSTEM ADJ BRACKETS	8.55
K12 SYSTEM ADAPTERS FOR ALUMINIUM FRAME DOOR	8.57
LINK	8.60
KIARO	8.67
KIARO LED	8.77
KIARO WITH SCREW FIXING DOOR BRACKET WITHOUT MILLING ON THE DOOR	8.89
KIARO FOX	8.94
KIARO SKIN	8.99
KIARO DECK - Alternative applications of Kiaro	8.107
KIARO EASY	8.111



## KRABY SYSTEM LIFT UP



PATENTED  
Certificates available  
on request.



### INSTALLATION



#### VERY IMPORTANT

The door bracket has to be placed in vertical position with the slot facing forwards.

recommended fixing countersunk head wood screws  $\varnothing 3,5 \times 16$  mm or Euro thread screws.

#### VERY IMPORTANT

The side bracket has to be placed with the slot in horizontal position and the open end facing the wall.

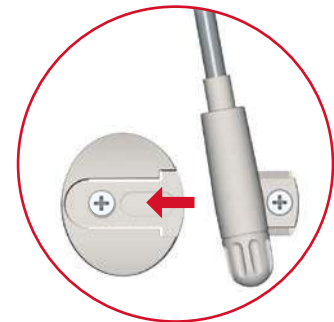
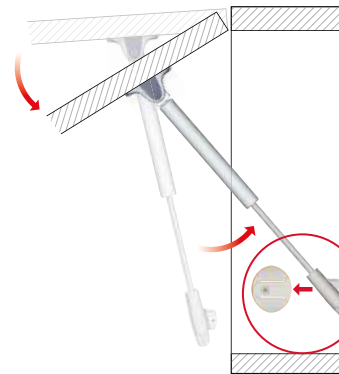
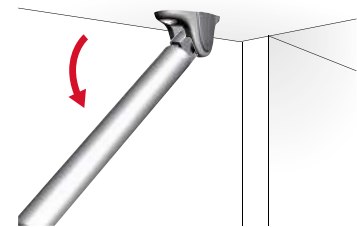
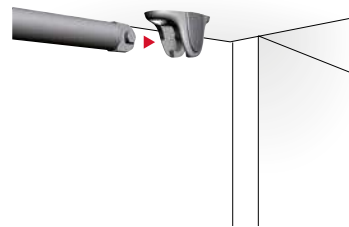
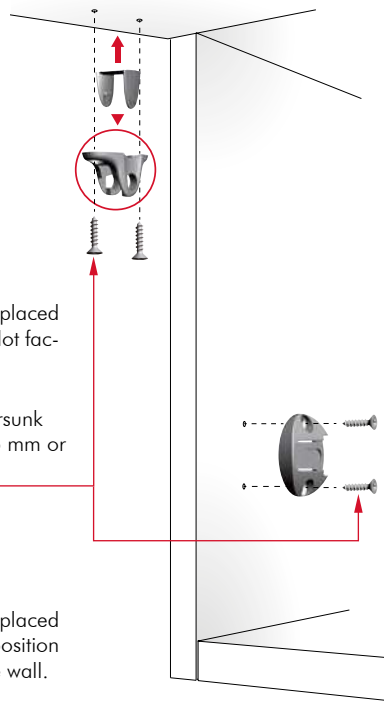

### ADJUSTMENTS

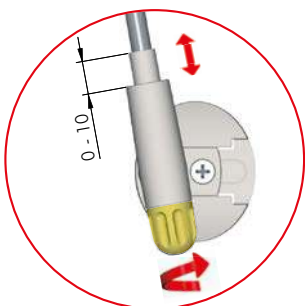

#### INCREASE OPENING ANGLE

Rotate the rotary knob.

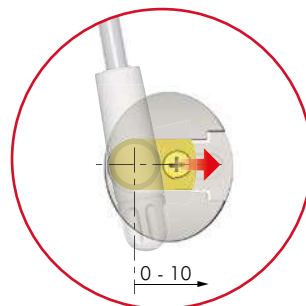

#### REDUCE OPENING ANGLE

Move forward and backward the piston base plate in the bracket slot.

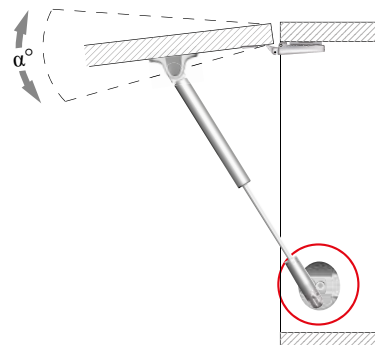

### LOCKING

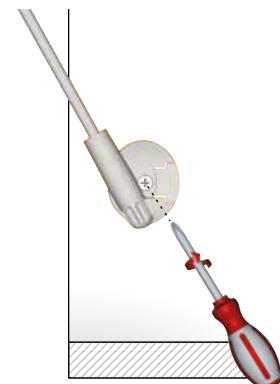

## LIFT UP

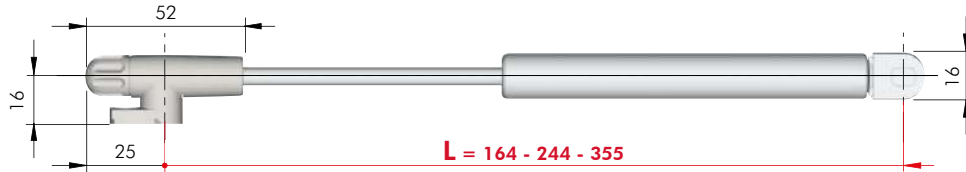
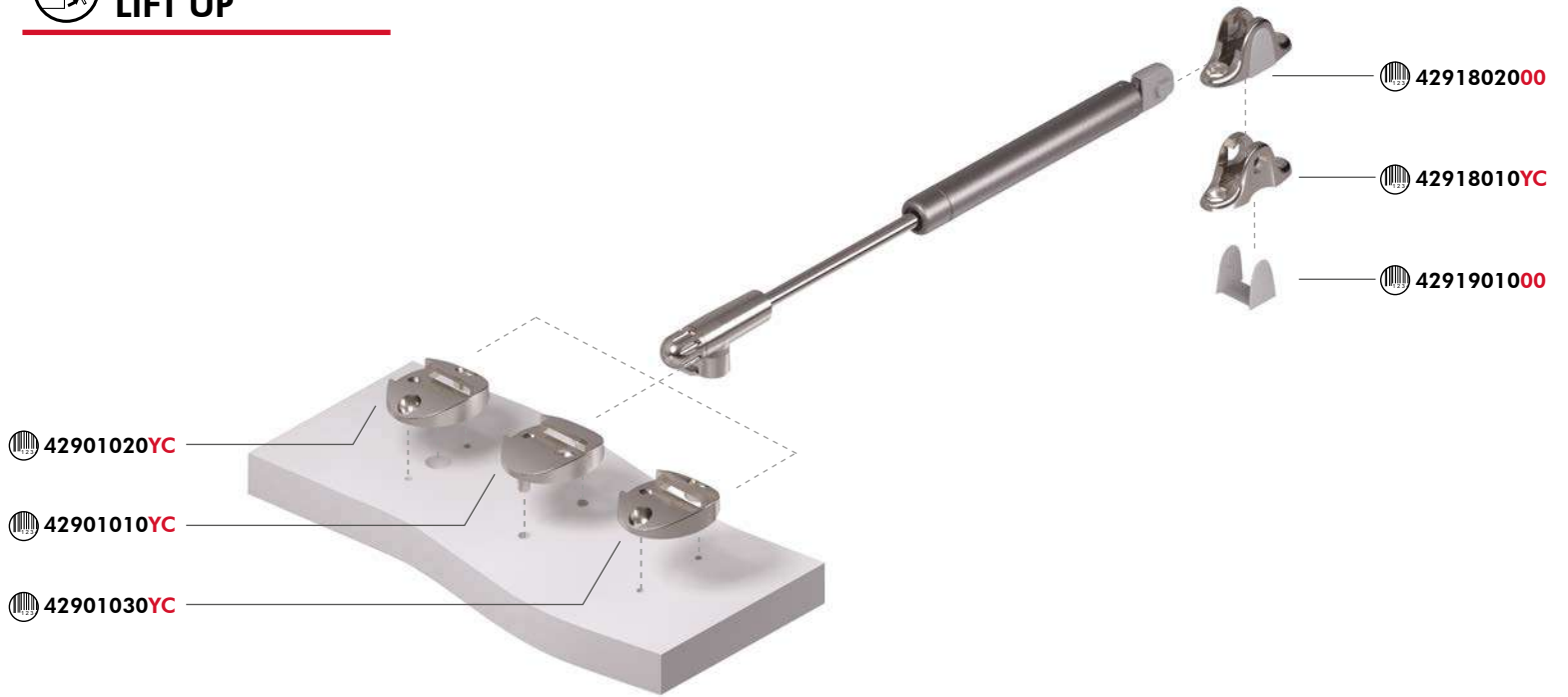

ZAnk EP ST

= 100 pcs.

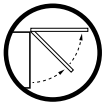

### KRABY FRICTION VERSION

Further newton strengths available on request.

L			N
164	42001010UZ		45
	42002010UZ		60

L			N
244	42011010UZ		45
	42012010UZ		60
	42013010UZ		90
	42014010UZ		120

L			N
355	42030010UZ		45
	42031010UZ		60
	42032010UZ		90
	42033010UZ		120

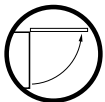

### KRABY AUTOMATIC VERSION

Further newton strengths available on request.

L			N
164	42101010UZ		50
	42102010UZ		80
	42103010UZ		120

L			N
244	42110010UZ		50
	42111010UZ		80
	42112010UZ		100
	42113010UZ		120
	42114010UZ		140

L			N
355	42130010UZ		50
	42131010UZ		80
	42132010UZ		100
	42133010UZ		120

8





## Number of stays chart - L 164 mm

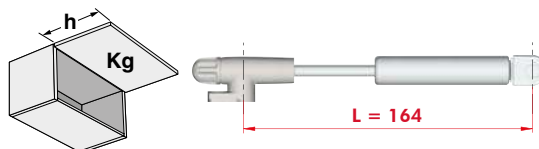

Rev. 02

h	Krabby version	Door weight (Kg)										Krabby version
		1	2	3	4	5	6	7	8	9	10	
230 - 274	Automatic	1x80N	2x80N		2x120N		3x120N			4x120N		Automatic
	Friction	1x45N	2x45N			2x60N			3x60N			Friction
275 - 325	Automatic	1x80N	2x80N	2x120N		3x120N		4x120N			Automatic	
	Friction	1x60N	2x45N		2x60N	3x60N	4x60N			Friction		

## Number of stays chart - L 244 mm

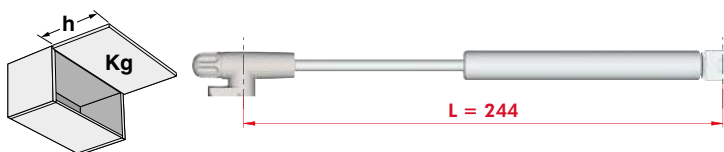

Rev. 02

h	Krabby version	Door weight (Kg)													Krabby version
		1	2	3	4	5	6	7	8	9	10	11	12	13	
300 - 324	Automatic	1x80N		2x50N		2x80N		2x100N		2x120N		2x140N	2x160N*		Automatic
	Friction	1x45N		1x60N	2x45N			2x60N			2x90N			Friction	
325 - 374	Automatic	1x80N	2x50N	2x80N		2x100N	2x120N	2x140N	2x160N*		2x180N*		2x180N*	Automatic	
	Friction	1x45N	1x60N	2x45N		2x60N			2x90N			2x120N		Friction	
375 - 424	Automatic	1x80N	2x50N	2x80N		2x100N	2x120N	2x140N	2x160N*		2x180N*	2x240N*		Automatic	
	Friction	1x45N	1x60N	2x45N		2x60N			2x90N		2x120N			Friction	
425 - 474	Automatic	2x50N		2x80N		2x100N	2x120N	2x140N	2x160N*		2x180N*		3x160N*	Automatic	
	Friction	1x60N		2x45N		2x60N			2x90N			2x120N	3x90N	Friction	
475 - 524	Automatic	2x80N		2x100N		2x120N	2x140N	2x160N*		2x180N*		3x160N*		Automatic	
	Friction	2x45N		2x60N			2x90N	2x120N	3x90N		3x120N		Friction		

\* Strengths available on request.

## Number of stays chart - L 355 mm

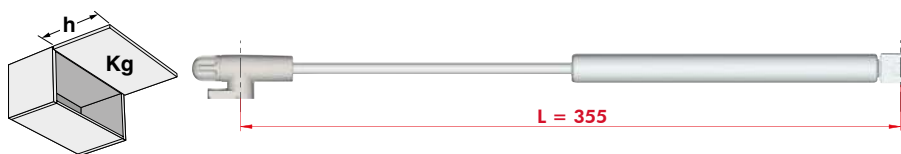

Rev. 02

h	Krabby version	Door weight (Kg)													Krabby version
		1	2	3	4	5	6	7	8	9	10	11	12	13	
400 - 424	Automatic	1x80N		2x50N		2x80N			2x100N	2x120N	2x160N		Automatic		
	Friction	2x45N						2x60N						Friction	
425 - 474	Automatic	1x80N	2x50N	2x80N		2x100N	2x120N	2x160N		Automatic					
	Friction	2x45N						2x60N			2x90N		Friction		
475 - 524	Automatic	1x80N	2x50N	2x80N		2x100N	2x120N	2x160N	2x180N	2x200N	Automatic				
	Friction	2x45N						2x60N			2x90N		Friction		
525 - 574	Automatic	1x80N	2x50N	2x80N		2x100N	2x100N	2x160N		2x180N	2x200N	Automatic			
	Friction	2x45N						2x60N			2x90N		Friction		
575 - 624	Automatic	2x50N		2x80N	2x100N	2x120N	2x160N		2x180N	2x200N		Automatic			
	Friction	2x45N						2x60N			2x90N		Friction		
625 - 700	Automatic	2x50N		2x80N	2x100N	2x120N	2x160N		2x180N	2x200N		Automatic			
	Friction	2x45N			2x60N			2x90N		2x120N		Friction			

These are experimental results to be checked by the customer. Our Technical Department is at your disposal to test further cases out of this charts.

## LIFT UP DRILLING PLANS WITH STANDARD HINGES OPENING WITH HANDLE

KRABY CONFIGURATOR:

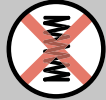
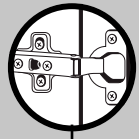
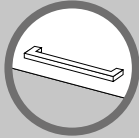

L 164 mm

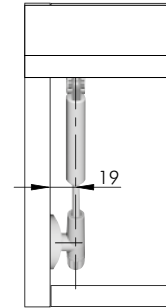
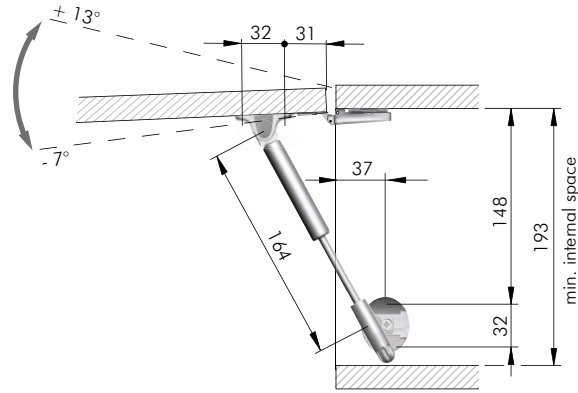

L 244 mm

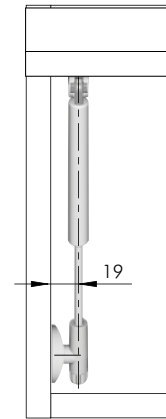
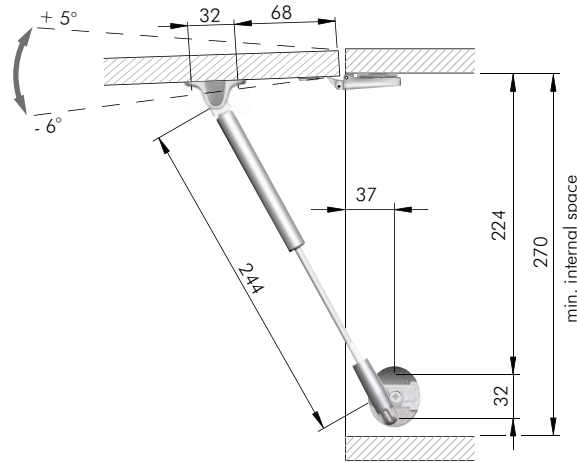

L 355 mm

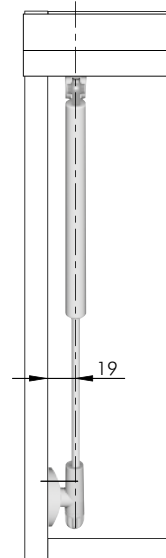
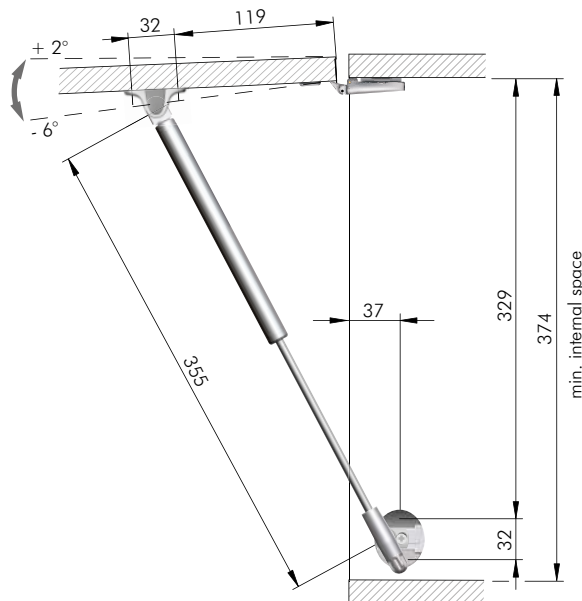

The dimensions of the above drilling plans refer to carcasses which use **standard sprung or unsprung hinges** and mounting plates 0 mm. Please note that the opening angle shown data is purely indicative. It varies with respect to the hinge brand and adjustment carried out.



Please note that in case of use of **unsprung hinges**, magnet K Lock is required. For details refer to section "PUSH CATCHES & MAGNETIC CATCHES".



## LIFT UP DRILLING PLANS WITH STANDARD HINGES PUSH TO OPEN

KRABY CONFIGURATOR:



L 164 mm

K Push Tech 14 mm

- With magnet
- Visible or invisible version

For details refer to section "PUSH CATCHES & MAGNETIC CATCHES".

L 244 mm

K Push Tech 14 mm

- With magnet
- Visible or invisible version

For details refer to section "PUSH CATCHES & MAGNETIC CATCHES".

L 355 mm

K Push Tech 14 mm

- With magnet
- Visible or invisible version

For details refer to section "PUSH CATCHES & MAGNETIC CATCHES".

The dimensions of the above drilling plans refer to carcasses which use **standard unsprung hinges** and mounting plates 0 mm. Please note that the opening angle shown data is purely indicative. It varies with respect to the hinge brand and adjustment carried out.

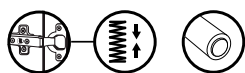

Please note that utilization with **standard sprung hinges** and **K Push Tech with buffer** is also possible. In such case, after the door is initially released by K Push Tech, a manual opening approx. 7cm is required (in order to win the spring resistance). Consequently, the door will automatically open to the fullest.  
For details refer to section "PUSH CATCHES & MAGNETIC CATCHES".

## KRABBY SYSTEM DROP DOWN



PATENTED   
Certificates available on request.

### INSTALLATION

recommended fixing countersunk head wood screws  $\varnothing 3,5 \times 16$  mm or Euro thread screws

#### VERY IMPORTANT

The side bracket has to be placed with the slot in horizontal position and the open end facing the wall.



#### VERY IMPORTANT

The door bracket has to be placed in vertical position with the slot facing forwards.

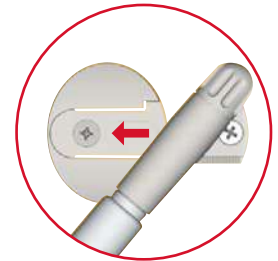
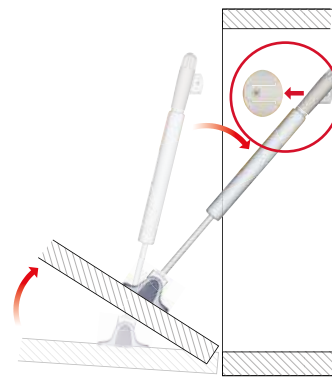
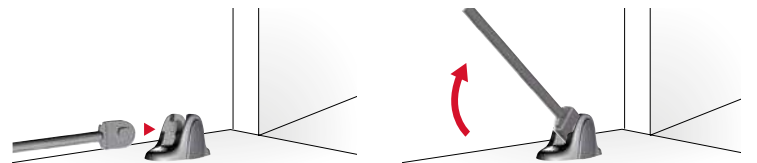
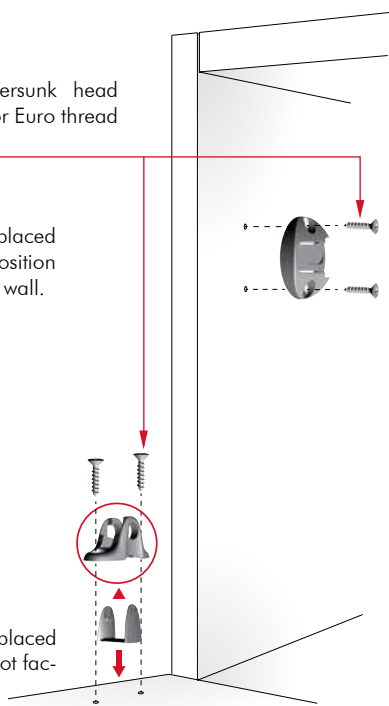

### ADJUSTMENTS

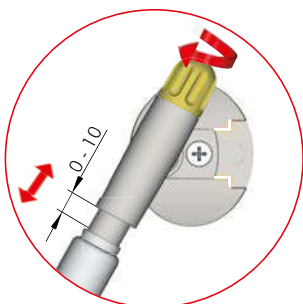

**INCREASE OPENING ANGLE**  
Rotate the rotary knob.

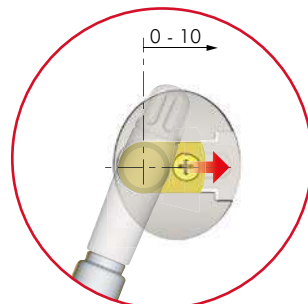

**REDUCE OPENING ANGLE**  
Move forward and backward the piston base plate in the bracket slot.

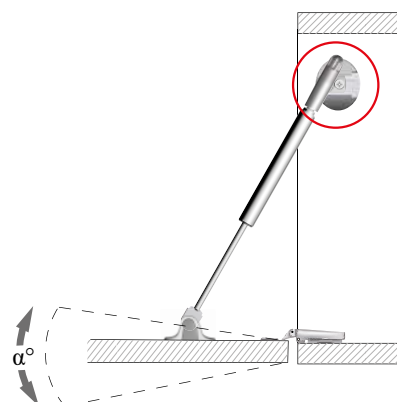

### LOCKING

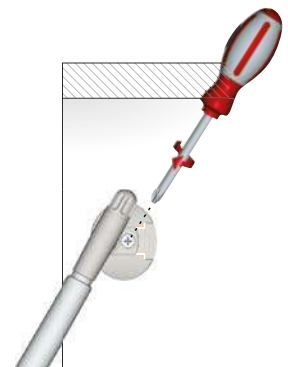



## DROP DOWN

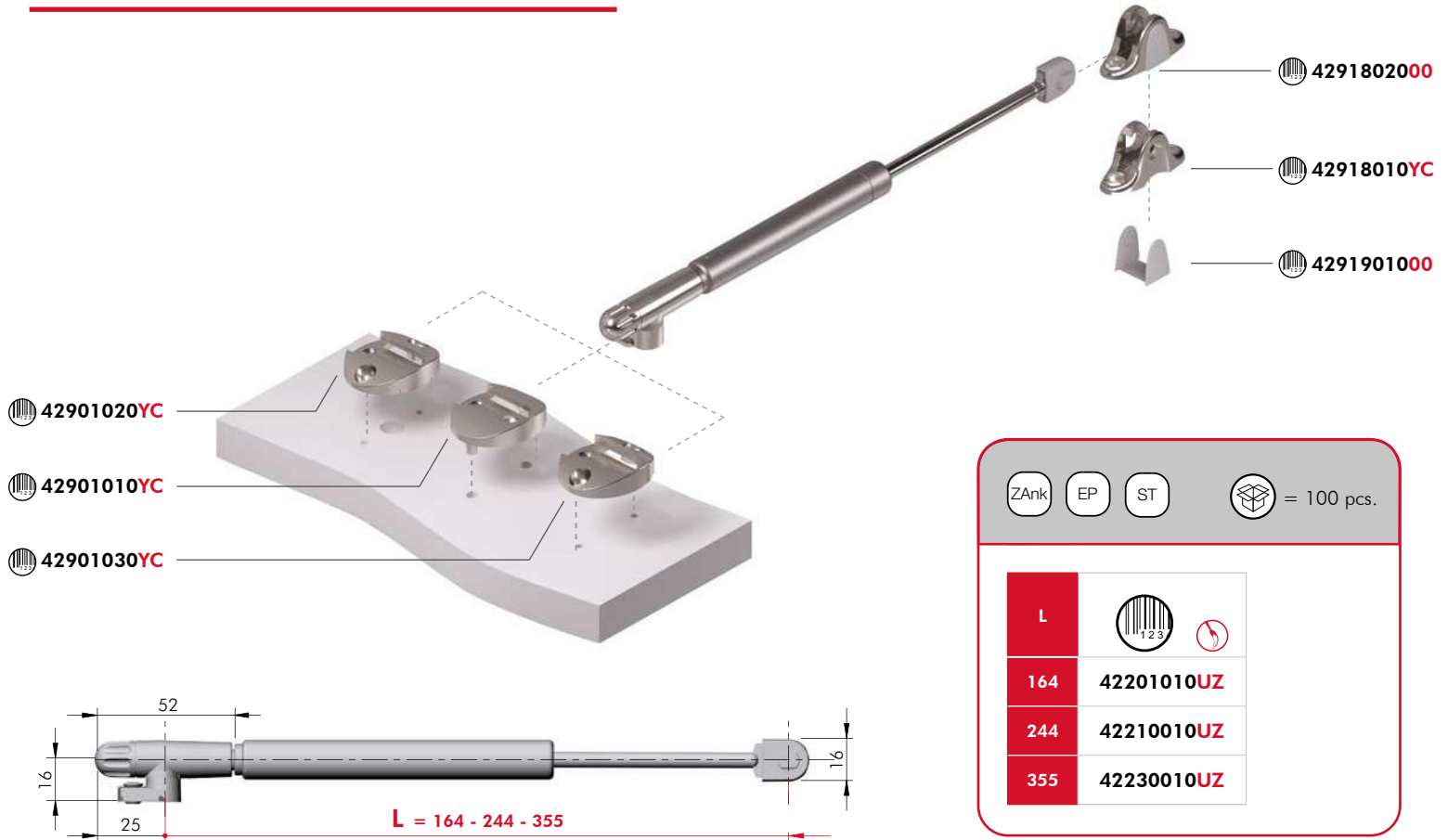

ZAnk	EP	ST	= 100 pcs.
<b>L</b>			
<b>164</b>	<b>42201010UZ</b>		
<b>244</b>	<b>42210010UZ</b>		
<b>355</b>	<b>42230010UZ</b>		

### Number of stays chart - L 164 mm

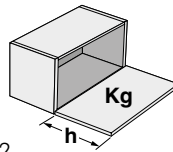

Rev. 02

h	Door weight (Kg)					
	1	2	3	4	5	6
200 - 284	2 x Kraby		3 x Kraby		4 x Kraby	

### Number of stays chart - L 244 mm

Rev. 02

h	Door weight (Kg)												
	1	2	3	4	5	6	7	8	9	10	11	12	13
280 - 324	2 x Kraby						3 x Kraby				4 x Kraby		
325 - 424	2 x Kraby						3 x Kraby				4 x Kraby		
425 - 500	2 x Kraby						3 x Kraby				4 x Kraby		

### Number of stays chart - L 355 mm

Rev. 02

h	Door weight (Kg)												
	1	2	3	4	5	6	7	8	9	10	11	12	13
380 - 500	2 x Kraby										3 x Kraby		
501 - 600	2 x Kraby										3 x Kraby		

These are experimental results to be checked by the customer. **In accordance with the actual European regulation, we suggest to use at least two stays for each door.** Our technical department is at your disposal to test further cases out of this chart.



## DROP DOWN DRILLING PLANS WITH KIMANA HINGE

KRABY CONFIGURATOR:



### L 164 mm



Magnet K Lock  
visible or invisible



K Push Tech 20 mm  
- With magnet  
- Visible or invisible

For details refer to section  
"PUSH CATCHES & MAGNETIC CATCHES".

Overcrossing 90° door opening  
angle, it negatively effects the  
Kimana hinges. 90° max

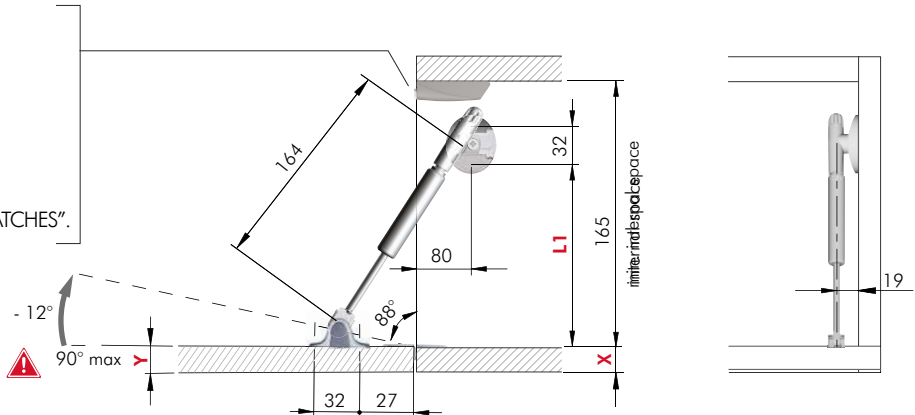

Cabinet (X)		Door (Y)		L1
16 mm	4 mm	16 mm	2 mm	117
16 mm	4 mm	19 mm	-	119
18 mm	2 mm	18 mm	-	117
19 mm	-	16 mm	2 mm	113
19 mm	-	19 mm	-	115
20 mm	-	20 mm	-	115

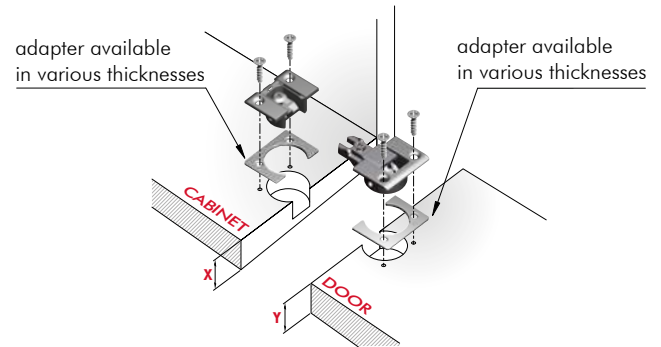

For Kimana and adapter details refer to section "HINGES".

### L 244 mm



Magnet K Lock  
visible or invisible



K Push Tech 20 mm  
- With magnet  
- Visible or invisible

For details refer to section  
"PUSH CATCHES & MAGNETIC CATCHES".

Overcrossing 90° door opening  
angle, it negatively effects the  
Kimana hinges. 90° max

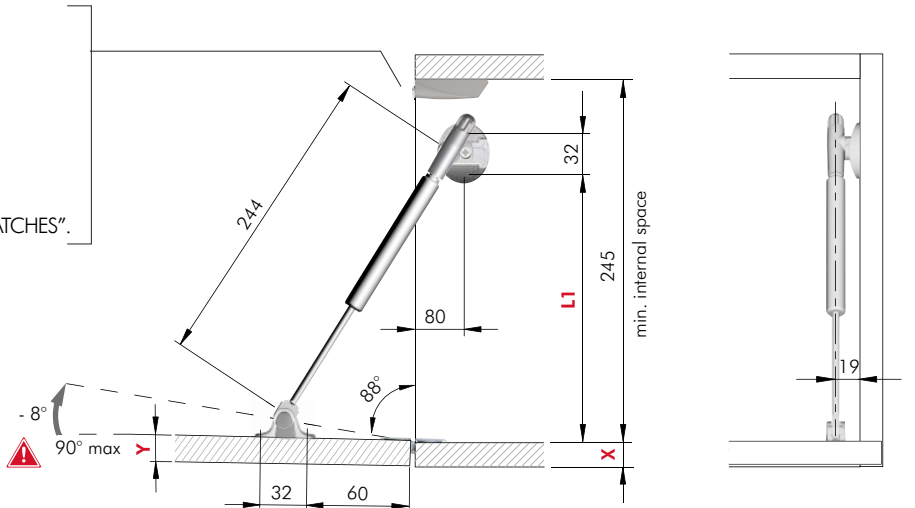

Cabinet (X)		Door (Y)		L1
16 mm	4 mm	16 mm	2 mm	197
16 mm	4 mm	19 mm	-	199
18 mm	2 mm	18 mm	-	197
19 mm	-	16 mm	2 mm	193
19 mm	-	19 mm	-	195
20 mm	-	20 mm	-	195

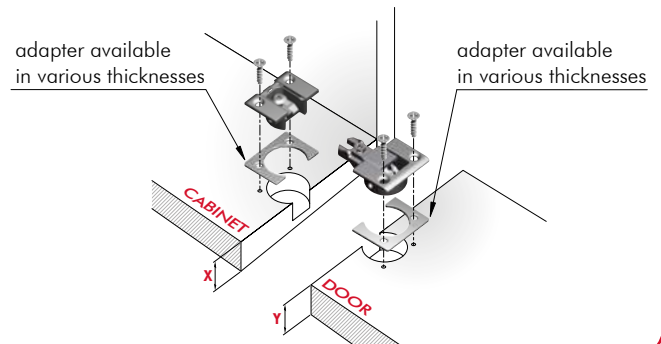

For Kimana and adapter details refer to section "HINGES".





L 355 mm



Magnet K Lock  
visible or invisible



K Push Tech 20 mm  
- With magnet  
- Visible or invisible

For details refer to section  
"PUSH CATCHES & MAGNETIC CATCHES".

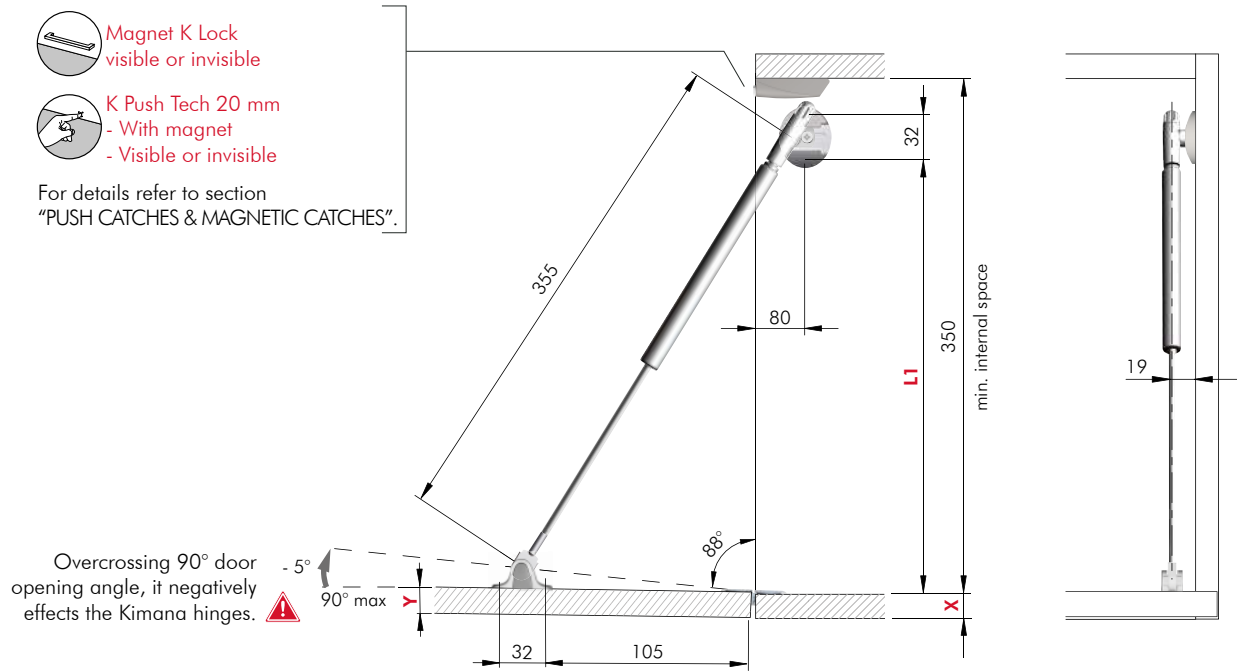

Cabinet (X)		Door (Y)		L1
16 mm	4 mm	16 mm	2 mm	302
16 mm	4 mm	19 mm	-	304
18 mm	2 mm	18 mm	-	302
19 mm	-	16 mm	2 mm	298
19 mm	-	19 mm	-	300
20 mm	-	20 mm	-	300

For Kimana and adapter details refer to section "HINGES".

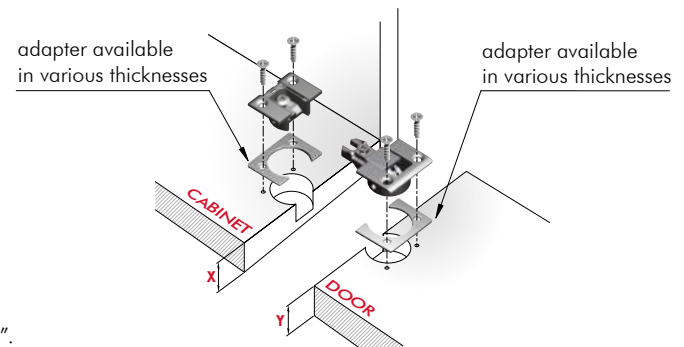



## DROP DOWN DRILLING PLANS WITH STANDARD HINGES OPENING WITH HANDLE

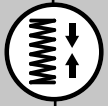
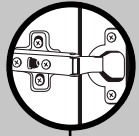
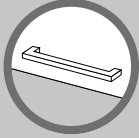

L 164 mm

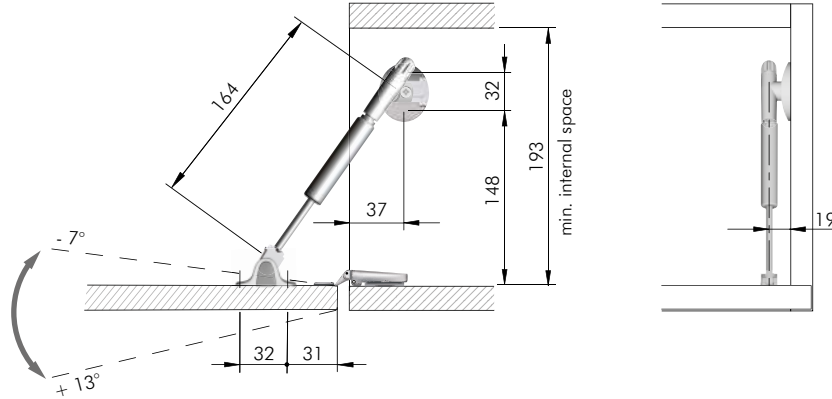

L 244 mm

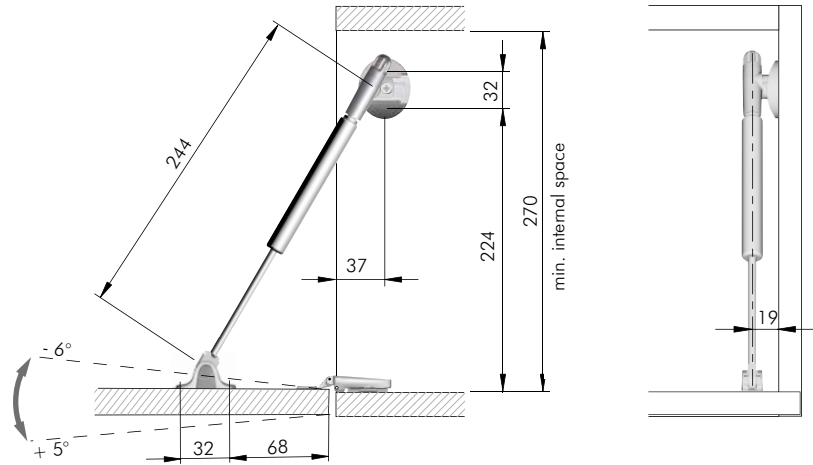

L 355 mm

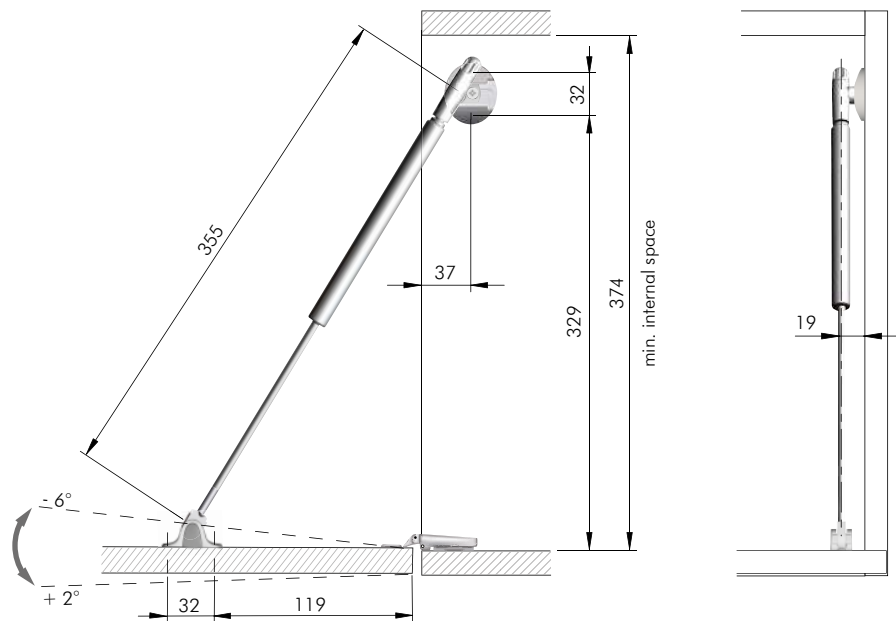

The dimensions of the drilling plans refer to carcasses which use **standard sprung hinges** and mounting plates 0 mm. Please note that the opening angle shown data is purely indicative. It varies with respect to the hinge brand and adjustment carried out.



Please note that in case of use of **unsprung hinges**, **magnet K Lock** is required. For details refer to section "PUSH CATCHES & MAGNETIC CATCHES".



## DROP DOWN DRILLING PLANS WITH STANDARD HINGES PUSH TO OPEN

KRABY CONFIGURATOR:

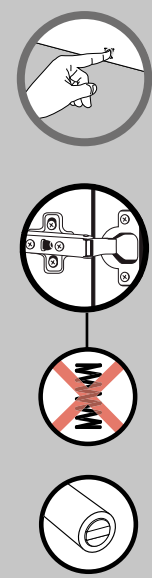

### L 164 mm



K Push Tech 14 mm  
- With magnet  
- Visible or invisible

For details refer to section  
"PUSH CATCHES & MAGNETIC CATCHES".

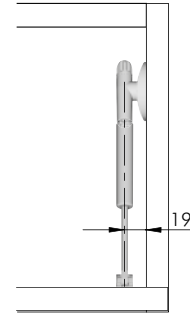
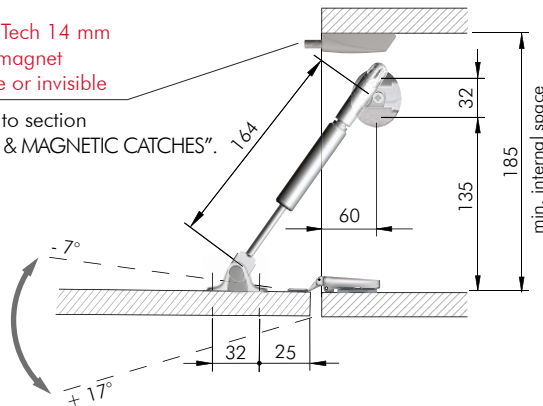

### L 244 mm



K Push Tech 14 mm  
- With magnet  
- Visible or invisible

For details refer to section  
"PUSH CATCHES & MAGNETIC CATCHES".

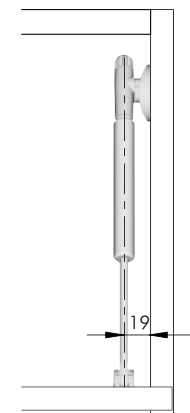
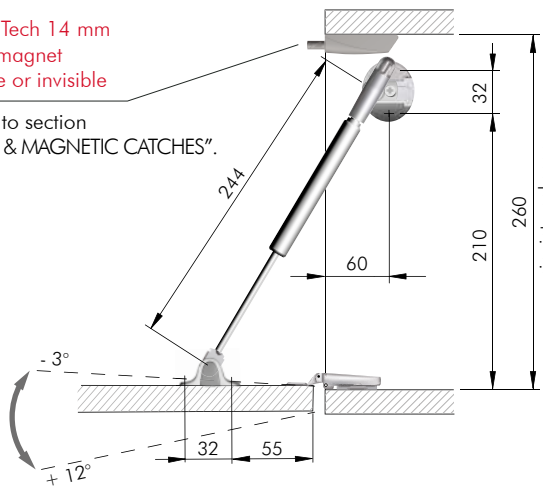

### L 355 mm



K Push Tech 14 mm  
- With magnet  
- Visible or invisible

For details refer to section  
"PUSH CATCHES & MAGNETIC CATCHES".

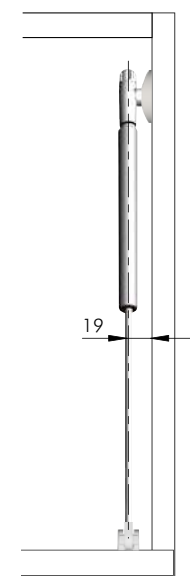
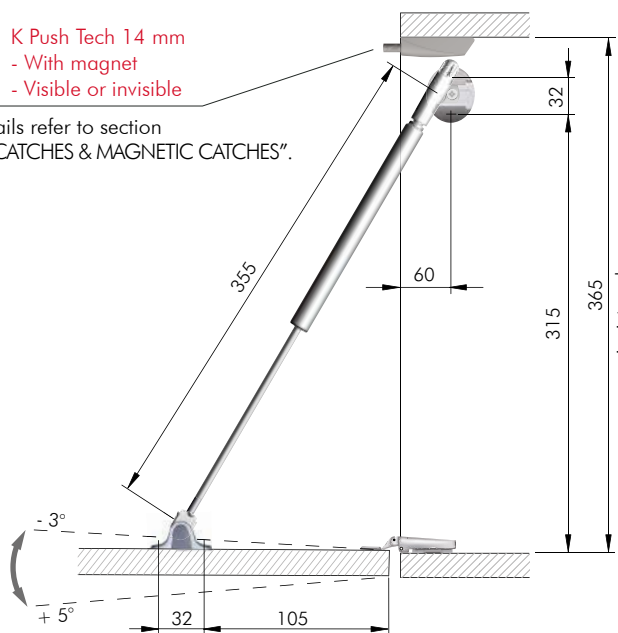

The dimensions of the drilling plan refer to carcasses which use **standard unsprung hinges** and mounting plates 0 mm. Please note that min and max opening angle shown data is purely indicative. It varies with respect to the hinge brand and adjustment carried out.

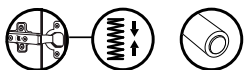

Please note that utilization with **standard sprung hinges** and **K Push Tech with buffer** is also possible. In such case, after the door is initially released by K Push Tech, a manual opening approx. 7cm is required (in order to win the spring resistance). Consequently, the door will automatically open to the fullest. For details refer to section "PUSH CATCHES & MAGNETIC CATCHES".



## DROP DOWN DRILLING PLANS WITH FLAP HINGE

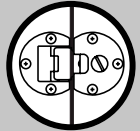
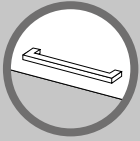

### L 164 mm

Magnet K Lock  
visible or invisible

K Push Tech 20 mm  
- With magnet  
- Visible or invisible

For details refer to section  
"PUSH CATCHES & MAGNETIC CATCHES".

Overcrossing 90° door opening  
angle, it negatively effects the  
flap hinges. ⚠️

- 12°  
90° max

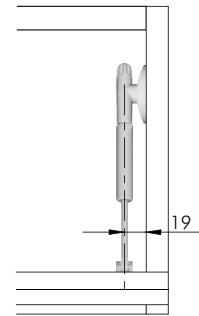
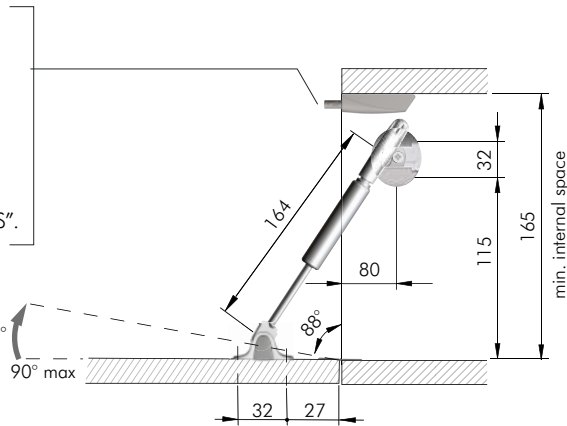

### L 244 mm

Magnet K Lock  
visible or invisible

K Push Tech 20 mm  
- With magnet  
- Visible or invisible

For details refer to section  
"PUSH CATCHES & MAGNETIC CATCHES".

Overcrossing 90° door opening  
angle, it negatively effects the  
flap hinges. ⚠️

- 8°  
90° max

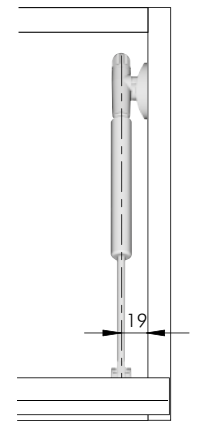
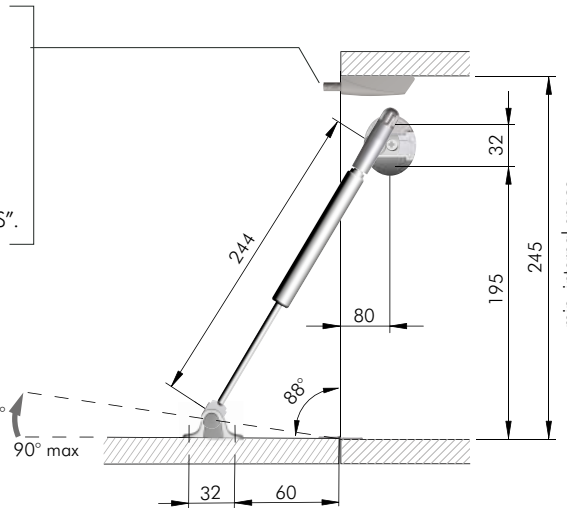

### L 355 mm

Magnet K Lock  
visible or invisible

K Push Tech 20 mm  
- With magnet  
- Visible or invisible

For details refer to section  
"PUSH CATCHES & MAGNETIC CATCHES".

Overcrossing 90°  
door opening  
angle, it negatively effects the  
flap hinges. ⚠️

- 5°  
90° max

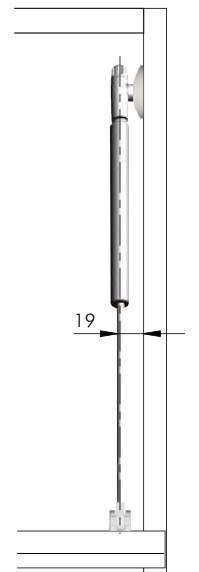
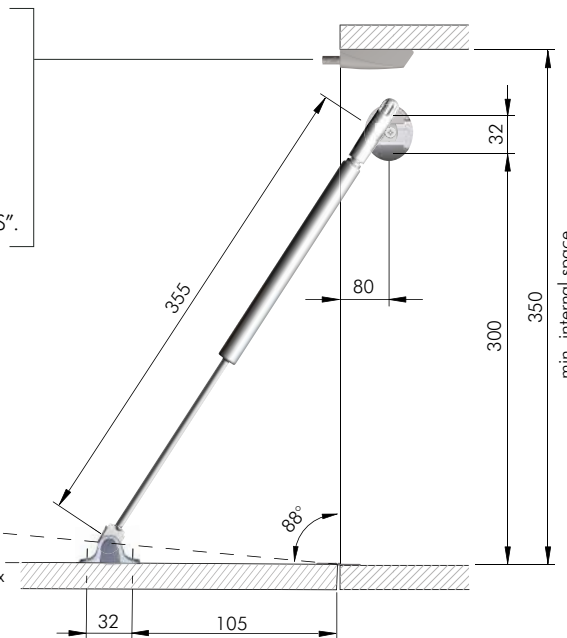



## KRABY BRACKETS

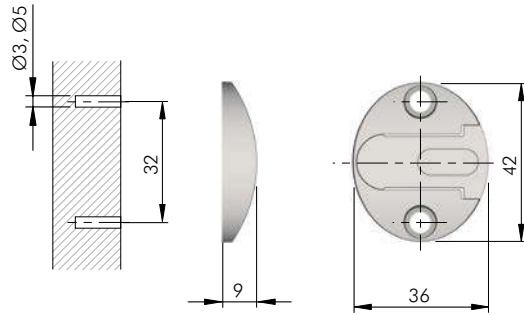

= Ø 3, Ø 5 mm

ZA

= 100 pcs.



**42901030YC**

recommended fixing countersunk  
head wood screw Ø 3,5 x 16 mm

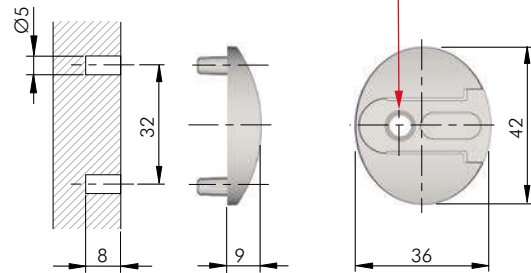

= Ø 5 mm

ZA

= 100 pcs.



**42901010YC**

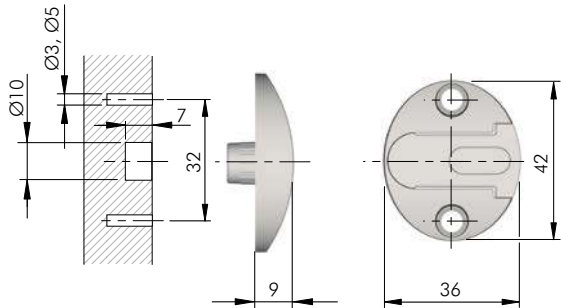

= Ø 3, Ø 5 mm + Ø 10 mm

ZA

= 100 pcs.



**42901020YC**

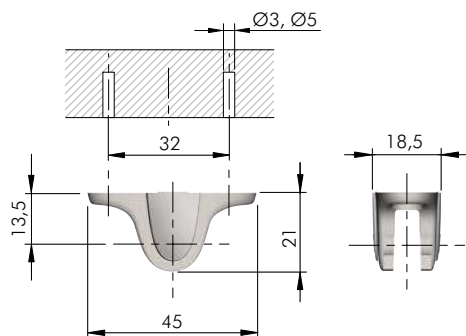

= Ø 3, Ø 5 mm

ZA

= 100 pcs.



**4291802000**

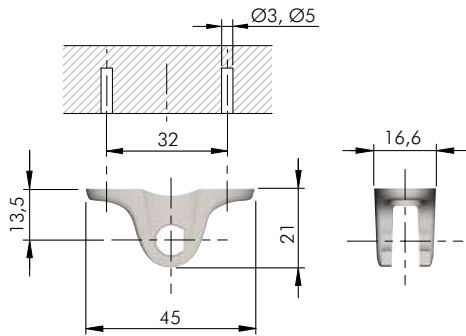

= Ø 3, Ø 5 mm  
 = 100 pcs.  
  
**42918010YC**

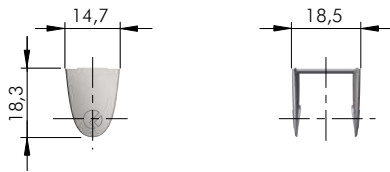

= 100 pcs.  
  
**4291901000**

## KRABY FIXING ACCESSORIES

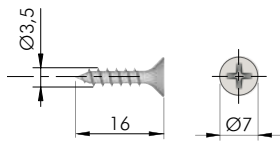

= Ø 2,5 mm +   
 = PZ2  
 = 10.000 pcs.  
  
**60101390YA**

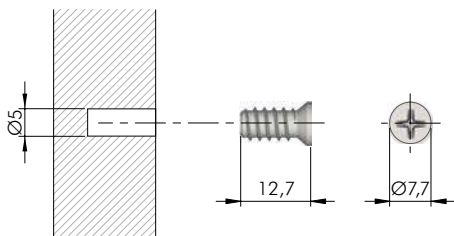

= Ø 5 mm +   
 = PZ2  
 = 5000 pcs.  
  
**60501050YA**

8





## KRABY ADAPTERS FOR ALUMINIUM FRAME DOOR

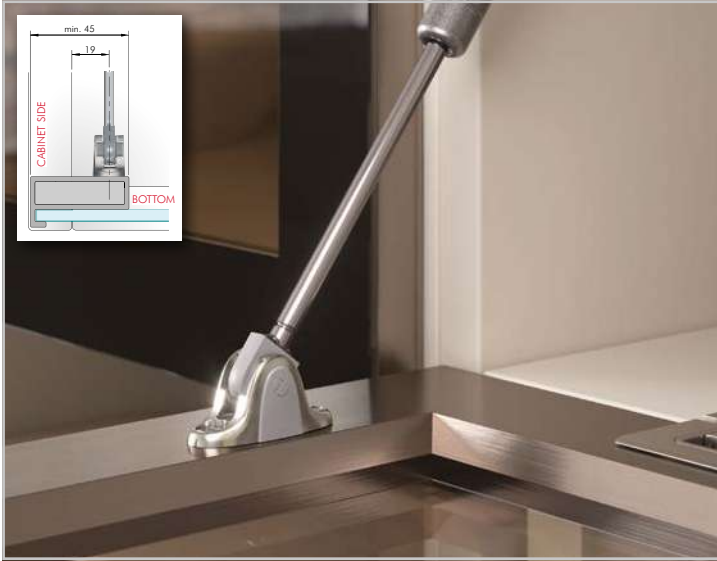

INSTALLATION ON WIDER ALUMINIUM FRAME DOOR



INSTALLATION ON NARROW ALUMINIUM FRAME DOOR

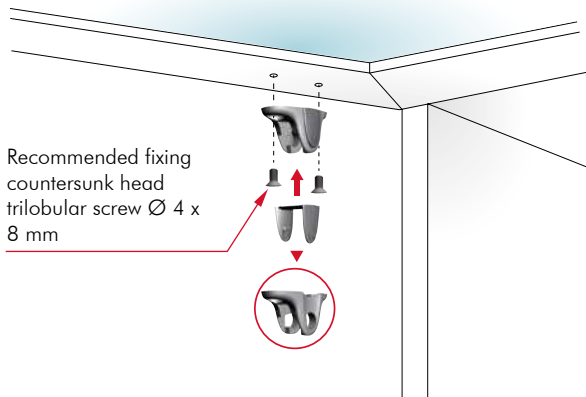

**VERY IMPORTANT**  
The door bracket has to be placed in vertical position with the slot facing forwards.

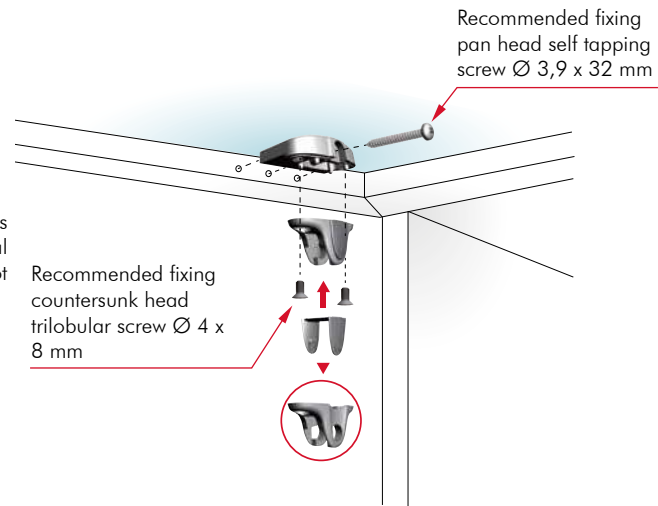

Recommended fixing pan head self tapping screw Ø 3,9 x 32 mm

### WIDER ALUMINIUM FRAME DOOR

Condition A

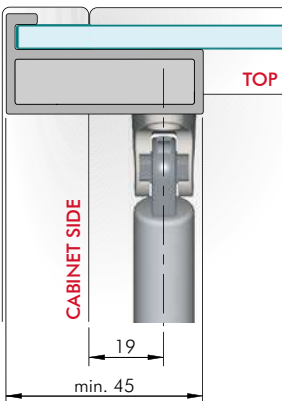

Assembling

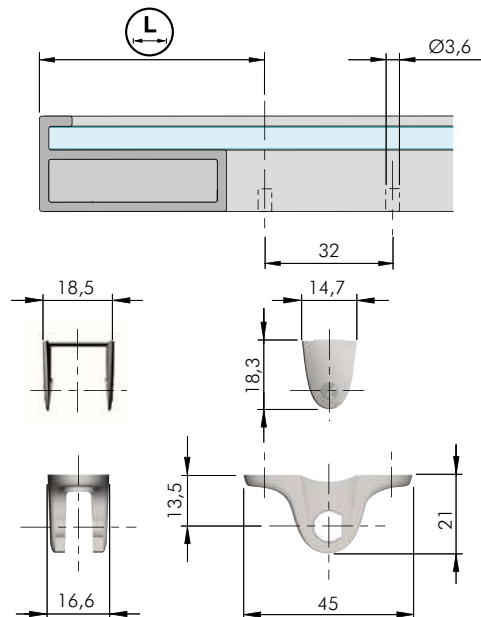

	= Ø 3,6 mm		= 100 pcs.
ZA	EP		
<b>42918010YC</b>			
<b>4291901000</b>			

# OPENING SYSTEMS FOR LIFT UP AND DROP DOWN DOORS

## NARROW ALUMINIUM FRAME DOOR

### Condition B

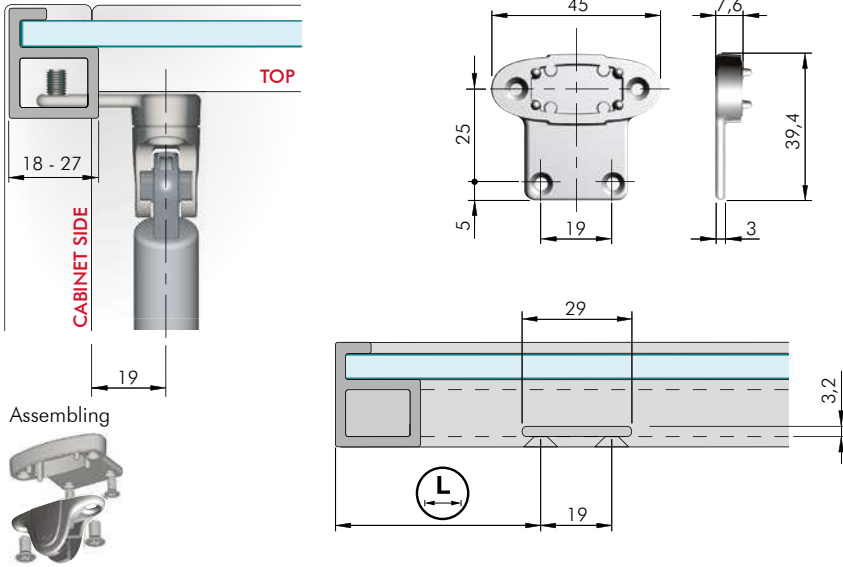

ZA

= 100 pcs.



42903010YC



42918010YC



4291901000



### Condition C

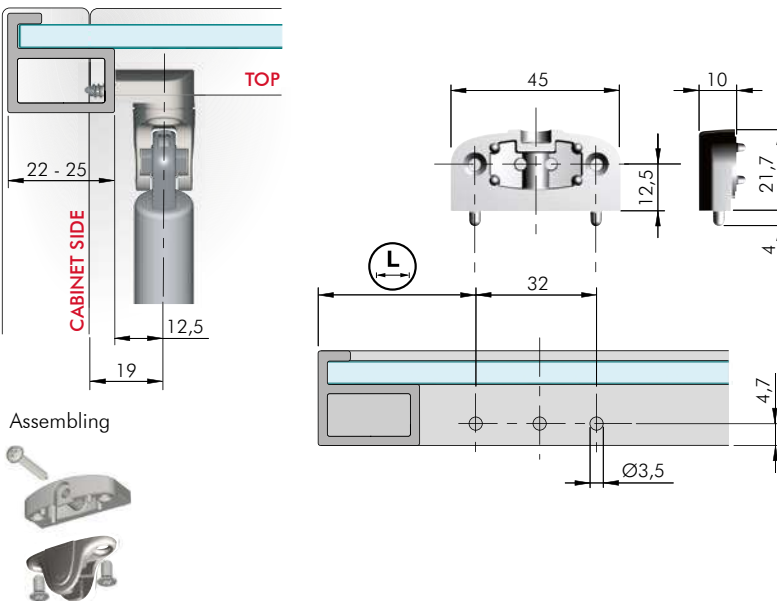

= Ø 3,5 mm

ZA

= 100 pcs.



42904010YC



42918010YC



4291901000



8

### Condition D

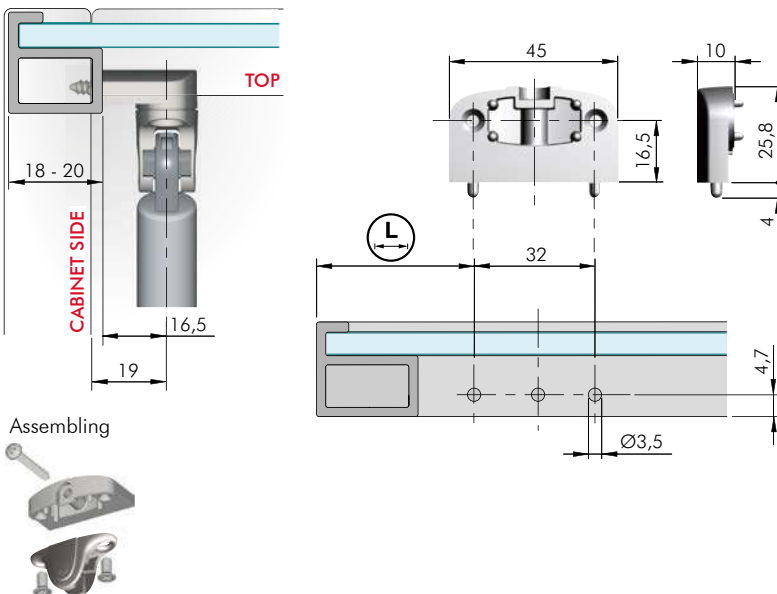

= Ø 3,5 mm

ZA

= 100 pcs.



42905010YC



42918010YC



4291901000



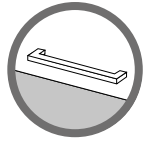

KRABY	L	
164	31	37,5
244	68	74,5
355	119	125,5



KRABY	L	
164	25	31,5
244	55	61,5
355	105	111,5

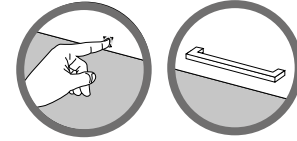

KRABY	L	
164	27	33,5
244	60	66,5
355	105	111,5

For details refer to related sections.

## ALUMINIUM ADAPTERS FIXING ACCESSORIES

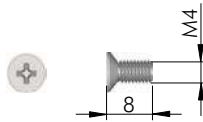

= PZ2  
 ST = on request



**42906010YA**

For wider aluminium frame and for condition A, B, C, D.

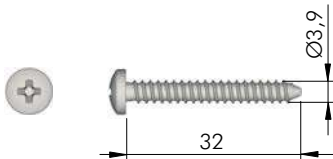

= PZ2  
 ST = on request



**60203410YA**

For condition C and D.



## KRABY FOR WRITING DESK



### INSTALLATION

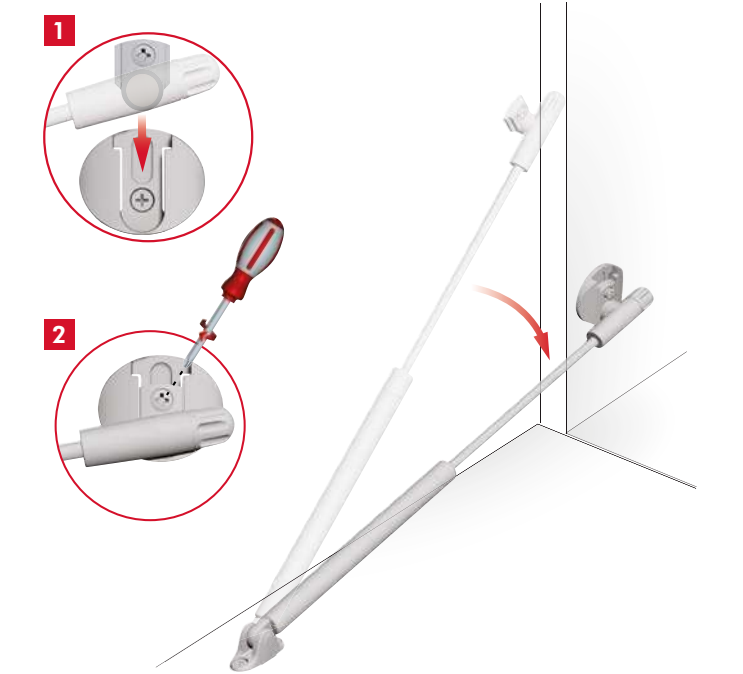
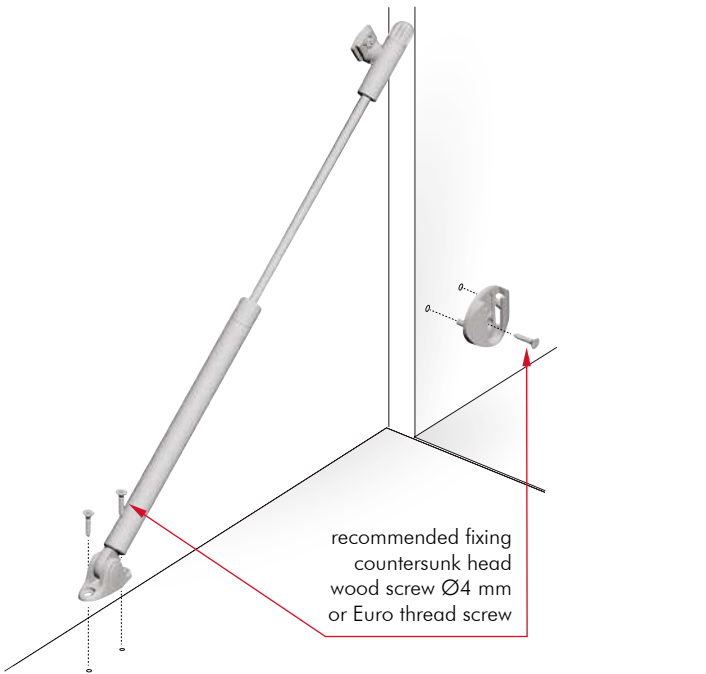

8

### ADJUSTMENTS

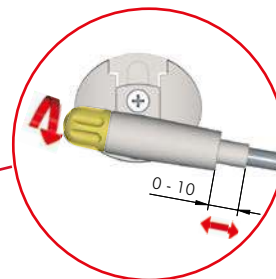
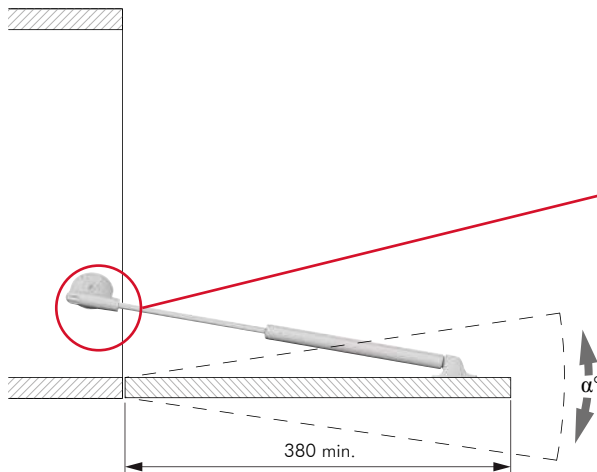
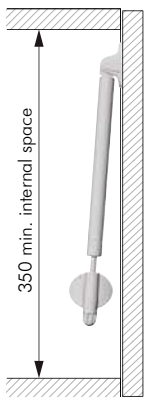

**INCREASE OPENING ANGLE**  
Rotate the rotary knob.

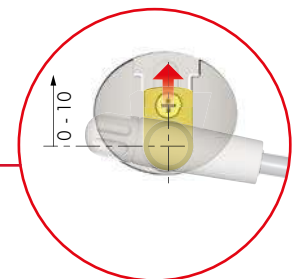

**REDUCE OPENING ANGLE**  
Move forward and backward the piston base plate in the bracket slot.



## DRILLING PLAN WITH KIMANA HINGE

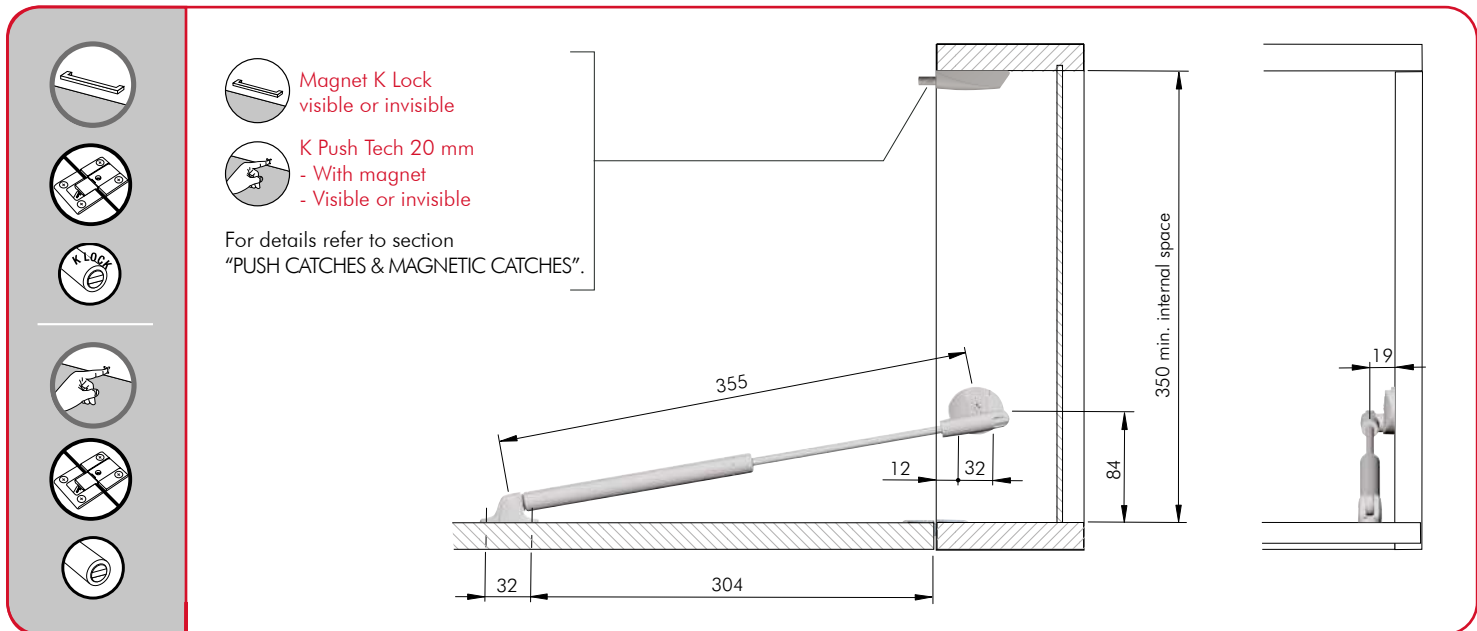

## Number of stays chart

Rev. 00

h	Door weight (Kg)												
	1	2	3	4	5	6	7	8	9	10	11	12	
380 - 450													2 x Kraby
451 - 550													2 x Kraby

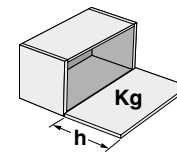

These are experimental results to be checked by the customer. Our technical department is at your disposal to test further cases out of this chart. **In accordance with the actual European regulation, it is necessary to use two lid stays for each door.**

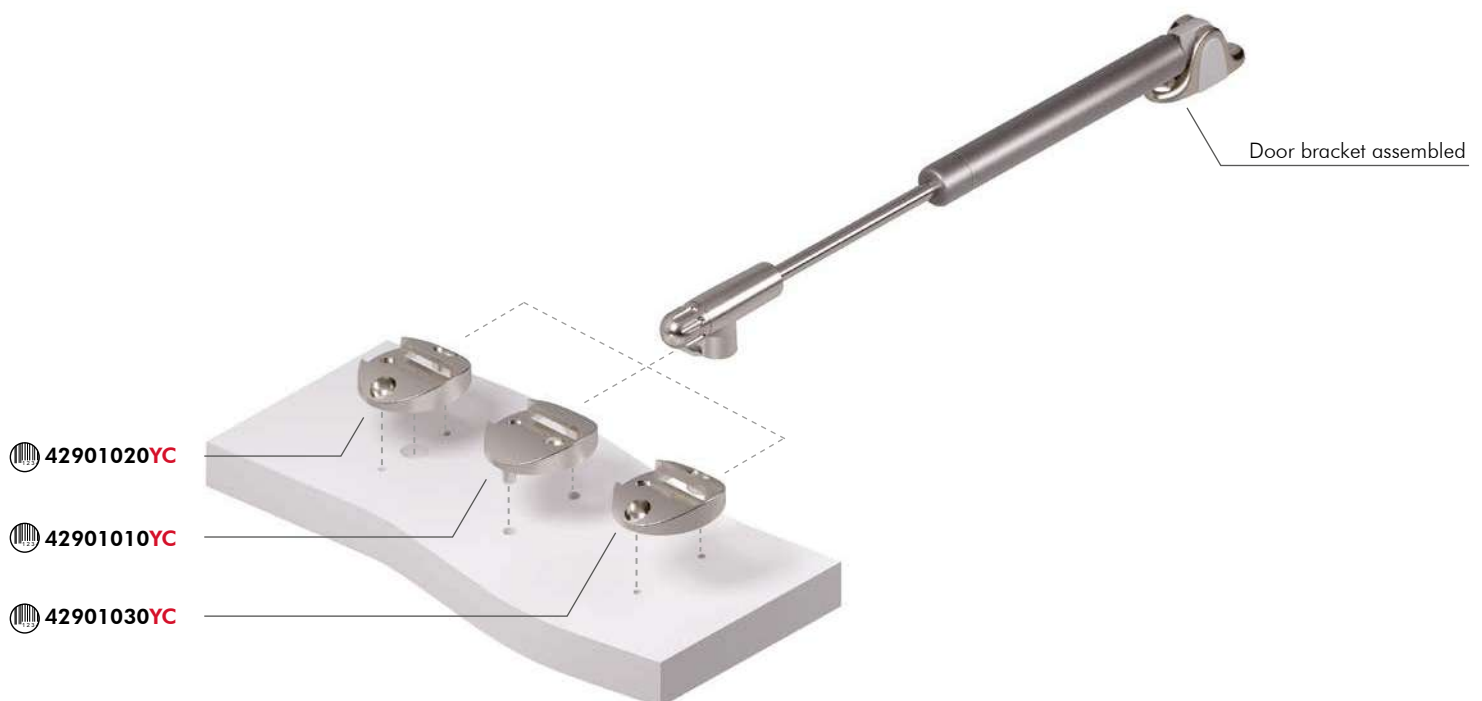



ZAnk EP ST = 50 pcs.

42250030UZ

## SIDE BRACKETS

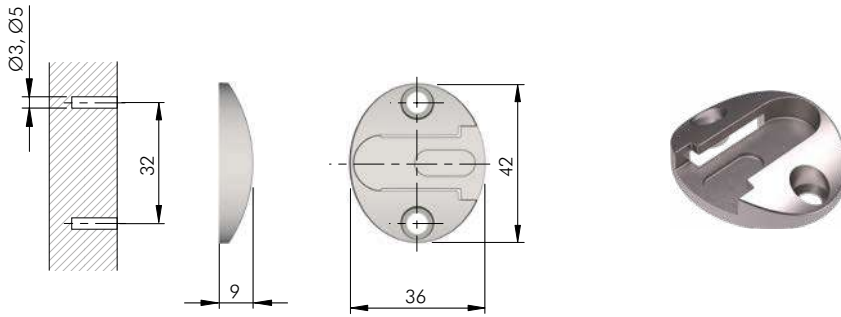

= Ø 3, Ø 5 mm

ZA = 100 pcs.

42901030YC

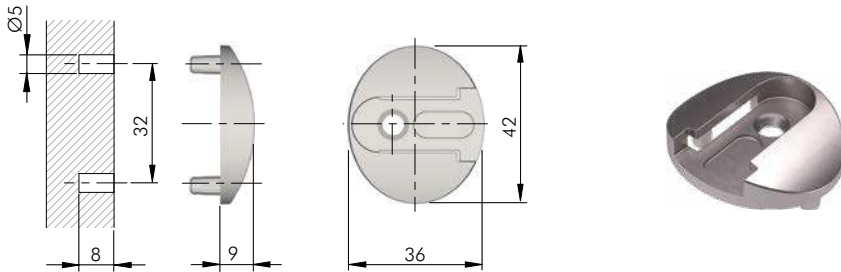

= Ø 5 mm

ZA = 100 pcs.

42901010YC

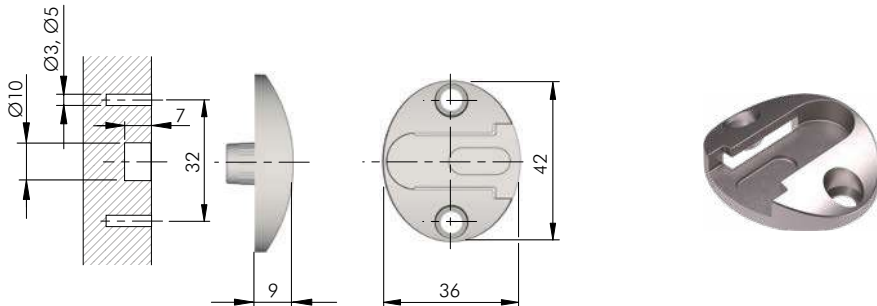

= Ø 3, Ø 5 mm + Ø 10 mm

ZA = 100 pcs.

42901020YC

8





## FIXING ACCESSORIES

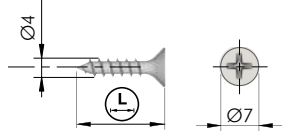

= Ø 2,5 mm +   
 = PZ2  
 = 10.000 pcs.

<b>60101570YA</b>		16
<b>60101580YA</b>		18

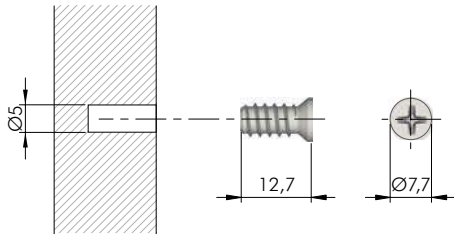

= Ø 5 mm +   
 = PZ2  
 = 5000 pcs.

<b>60501050YA</b>	

# Kraby, Compact and K12 System configurators

MAKE DESIGN EASIER WITH PRACTICAL APPLICATIONS

Use Italiana Ferramenta configurators



**Easy and intuitive configurator** which helps you to identify the right settings and drilling plans for Kraby, Compact and K12 System.

Main advantages are:

- Few guided steps to find the **correct set up of the product**.
- **Immediate response** without consulting any chart or document.
- Installation errors are avoided.
- Quick consultation of drilling plans.
- Possibility to **estimate the door weight**.
- Possibility to **print a report** with the suggested solutions.
- **Wide range of languages available** (Continuously updating).

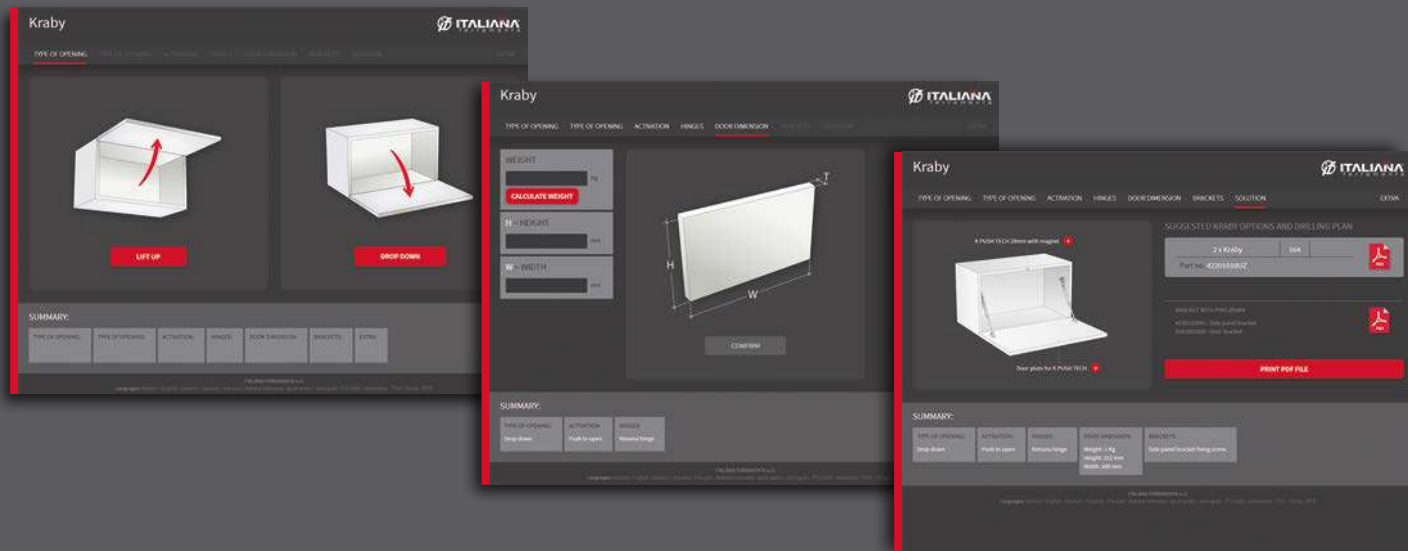



## COMPACT SYSTEM LIFT UP



PATENTED  
Certificates available  
on request.



### INSTALLATION

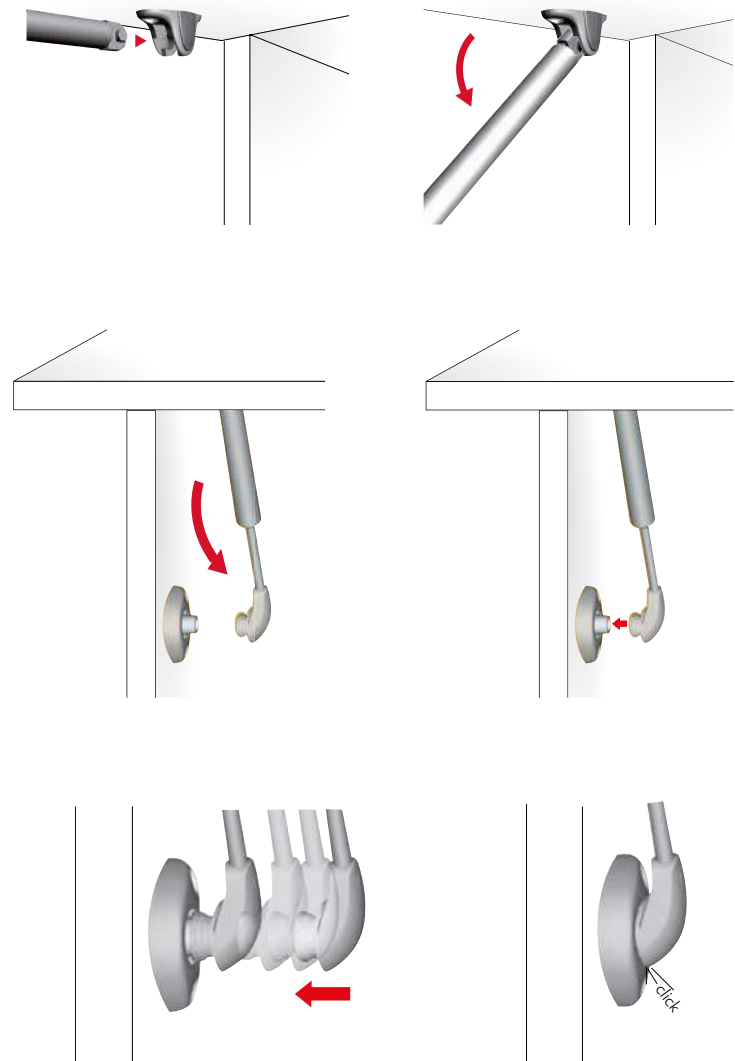
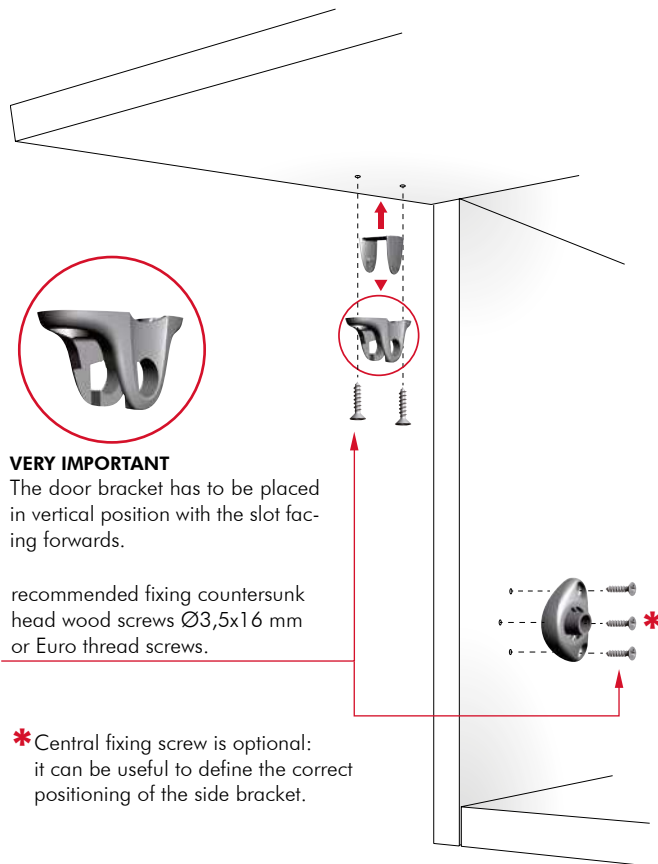

## LIFT UP



ZAnk EP ST

= 100 pcs.

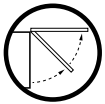

### COMPACT FRICTION VERSION

Further newton strengths available on request.

L			N
164	42301010UZ		45
	42302010UZ		60

L			N
244	42311010UZ		45
	42312010UZ		60
	42313010UZ		90
	42314010UZ		120

L			N
355	42330010UZ		45
	42331010UZ		60
	42332010UZ		90
	42333010UZ		120

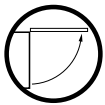

### COMPACT AUTOMATIC VERSION

Further newton strengths available on request.

L			N
164	42401010UZ		50
	42402010UZ		80
	42403010UZ		120

L			N
244	42410010UZ		50
	42412010UZ		80
	42413010UZ		100
	42414010UZ		120
	42415010UZ		140

L			N
355	42430010UZ		50
	42431010UZ		80
	42432010UZ		100
	42433010UZ		120



## Number of stays chart - L 164 mm

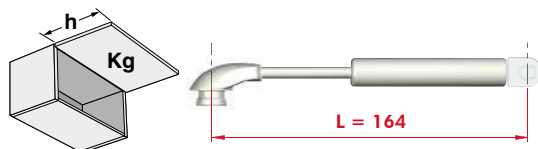

Rev. 02

h	Compact version	Door weight (Kg)										Compact version			
		1	2	3	4	5	6	7	8	9	10				
230 - 274	Automatic	1x80N	2x80N	2x120N	3x120N	4x120N									Automatic
	Friction	1x45N	2x45N	2x60N	3x60N										Friction
275 - 325	Automatic	1x80N	2x80N	2x120N	3x120N	4x120N								Automatic	
	Friction	1x60N	2x45N	2x60N	3x60N	4x60N								Friction	

## Number of stays chart - L 244 mm

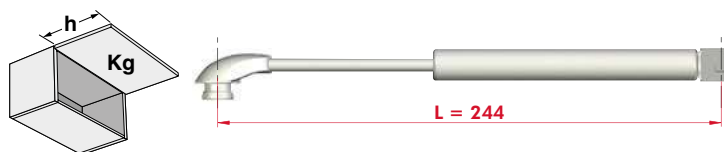

Rev. 02

h	Compact version	Door weight (Kg)													Compact version
		1	2	3	4	5	6	7	8	9	10	11	12	13	
300 - 324	Automatic	1x80N	2x50N	2x80N	2x100N	2x120N	2x140N	2x160N*	2x180N*	2x240N*					Automatic
	Friction	1x45N	1x60N	2x45N	2x60N	2x90N	2x120N	2x160N*	2x180N*	2x240N*					Friction
325 - 374	Automatic	1x80N	2x50N	2x80N	2x100N	2x120N	2x140N	2x160N*	2x180N*	2x240N*				Automatic	
	Friction	1x45N	1x60N	2x45N	2x60N	2x90N	2x120N	2x160N*	2x180N*	2x240N*				Friction	
375 - 424	Automatic	1x80N	2x50N	2x80N	2x100N	2x120N	2x140N	2x160N*	2x180N*	2x240N*				Automatic	
	Friction	1x45N	1x60N	2x45N	2x60N	2x90N	2x120N	2x160N*	2x180N*	2x240N*				Friction	
425 - 474	Automatic	2x50N	2x80N	2x100N	2x120N	2x140N	2x160N*	2x180N*	3x160N*					Automatic	
	Friction	1x60N	2x45N	2x60N	2x90N	2x120N	2x160N*	2x180N*	3x160N*					Friction	
475 - 524	Automatic	2x80N	2x100N	2x120N	2x140N	2x160N*	2x180N*	3x160N*						Automatic	
	Friction	2x45N	2x60N	2x90N	2x120N	3x90N	3x120N							Friction	

\* Strengths available on request.

## Number of stays chart - L 355 mm

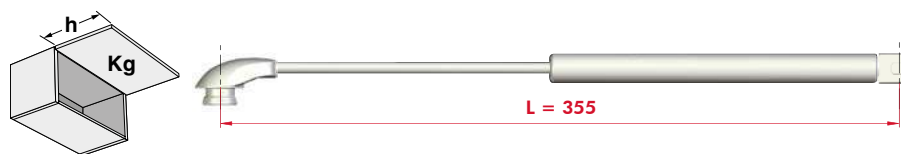

Rev. 02

h	Compact version	Door weight (Kg)													Compact version
		1	2	3	4	5	6	7	8	9	10	11	12	13	
400 - 424	Automatic	1x80N	2x50N	2x80N	2x100N	2x120N	2x160N								Automatic
	Friction	2x45N	2x60N	2x90N											Friction
425 - 474	Automatic	1x80N	2x50N	2x80N	2x100N	2x120N	2x160N	2x180N	2x200N					Automatic	
	Friction	2x45N	2x60N	2x90N										Friction	
475 - 524	Automatic	1x80N	2x50N	2x80N	2x100N	2x120N	2x160N	2x180N	2x200N					Automatic	
	Friction	2x45N	2x60N	2x90N										Friction	
525 - 574	Automatic	1x80N	2x50N	2x80N	2x100N	2x120N	2x160N	2x180N	2x200N					Automatic	
	Friction	2x45N	2x60N	2x90N										Friction	
575 - 624	Automatic	2x50N	2x80N	2x100N	2x120N	2x160N	2x180N	2x200N						Automatic	
	Friction	2x45N	2x60N	2x90N										Friction	
625 - 700	Automatic	2x50N	2x80N	2x100N	2x120N	2x160N	2x180N	2x200N						Automatic	
	Friction	2x45N	2x60N	2x90N	2x120N									Friction	

These are experimental results to be checked by the customer. Our Technical Department is at your disposal to test further cases out of this charts.

## LIFT UP DRILLING PLANS WITH STANDARD HINGES OPENING WITH HANDLE

COMPACT CONFIGURATOR:

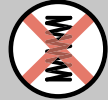
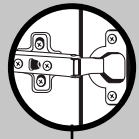
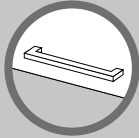

L 164 mm

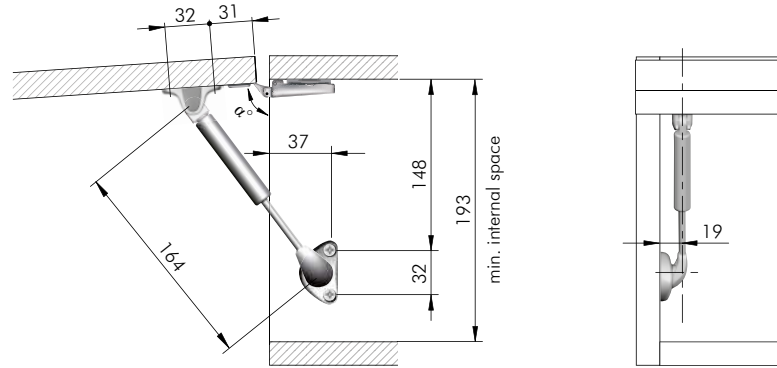

L 244 mm

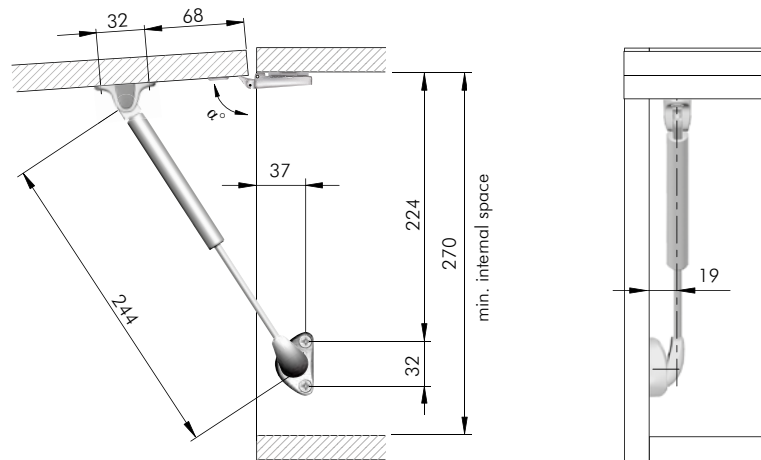

L 355 mm

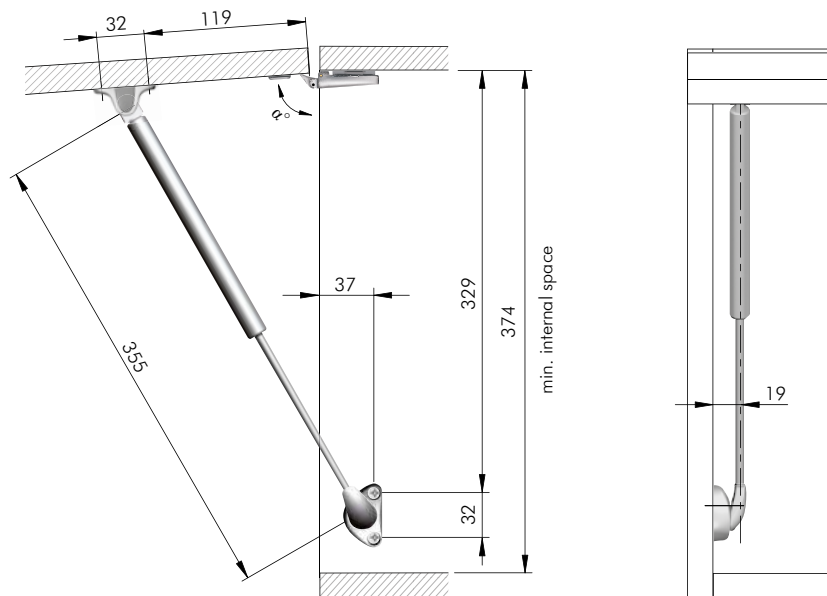

The dimensions of the above drilling plans refer to carcasses which use **standard sprung or unsprung hinges** and mounting plates 0 mm. Please note that the  $\alpha^\circ$  opening angle shown data is purely indicative. It varies with respect to the hinge brand and adjustment carried out.



Please note that in case of use of **unsprung hinges**, **magnet K Lock** is required. For details refer to section "PUSH CATCHES & MAGNETIC CATCHES".





## LIFT UP DRILLING PLANS WITH STANDARD HINGES PUSH TO OPEN

COMPACT CONFIGURATOR:



L 164 mm

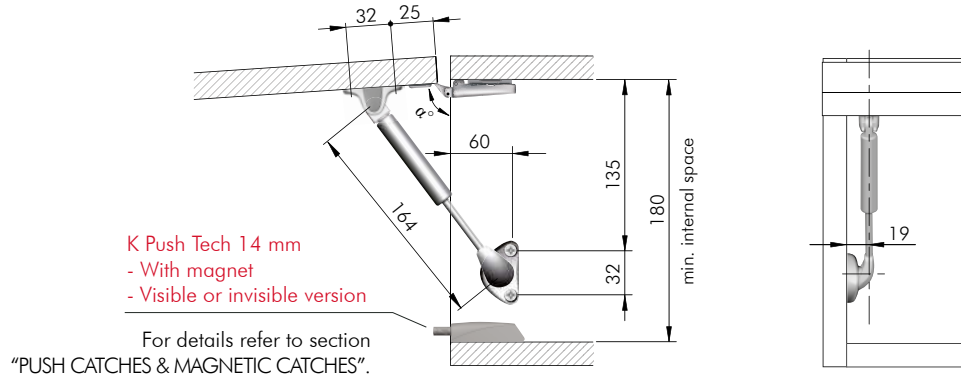

L 244 mm

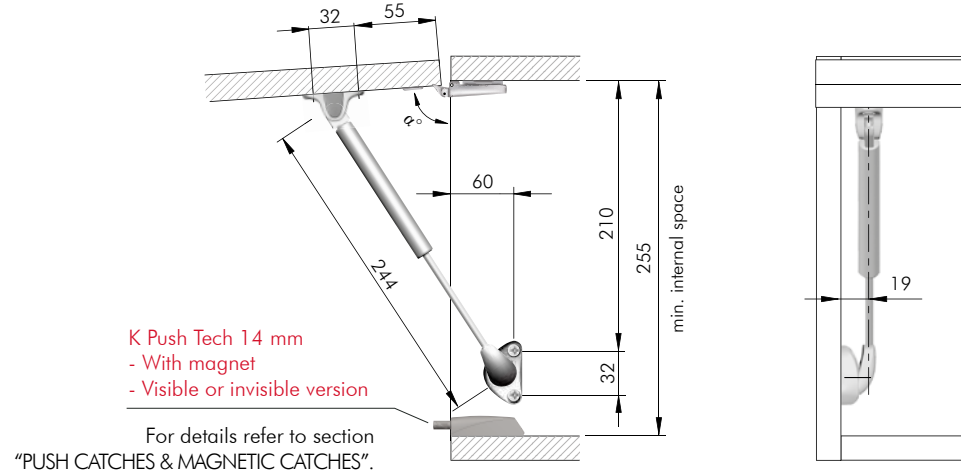

L 355 mm

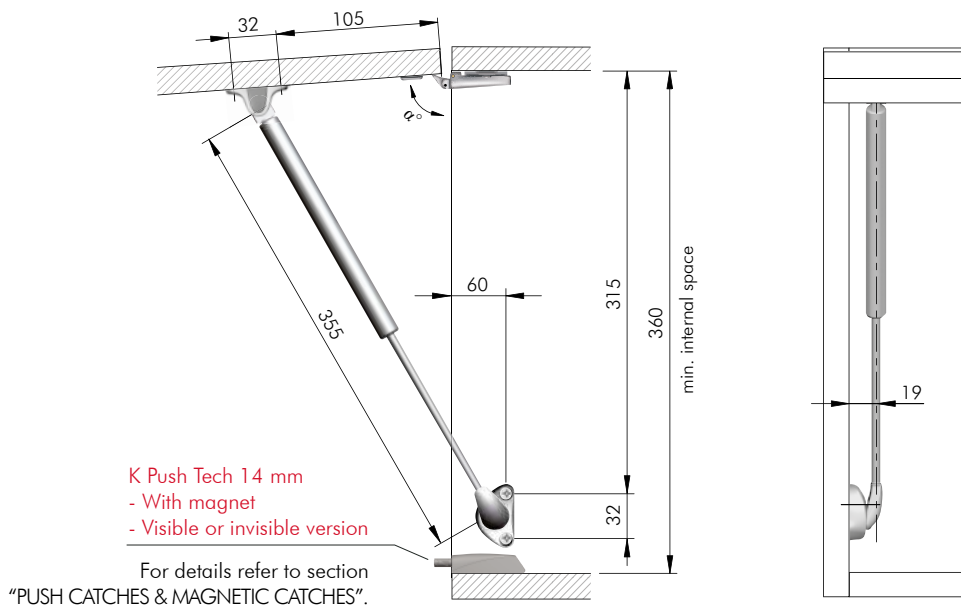

The dimensions of the above drilling plans refer to carcasses which use **standard unsprung hinges** and mounting plates 0 mm. Please note that the  $\alpha^\circ$  opening angle shown data is purely indicative. It varies with respect to the hinge brand and adjustment carried out.

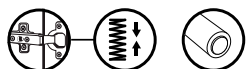

Please note that utilization with **standard sprung hinges** and **K Push Tech with buffer** is also possible. In such case, after the door is initially released by K Push Tech, a manual opening approx. 7cm is required (in order to win the spring resistance). Consequently, the door will automatically open to the fullest. For details refer to section "PUSH CATCHES & MAGNETIC CATCHES".

## COMPACT SYSTEM DROP DOWN



PATENTED   
Certificates available on request.

### INSTALLATION

recommended fixing countersunk head wood screws  $\varnothing 3,5 \times 16$  mm or Euro thread screws

\* Central fixing screw is optional:  
it can be useful to define the correct  
positioning of the side bracket.

#### VERY IMPORTANT

The side bracket has to be placed  
with the slot in horizontal position  
and the open end facing the wall.

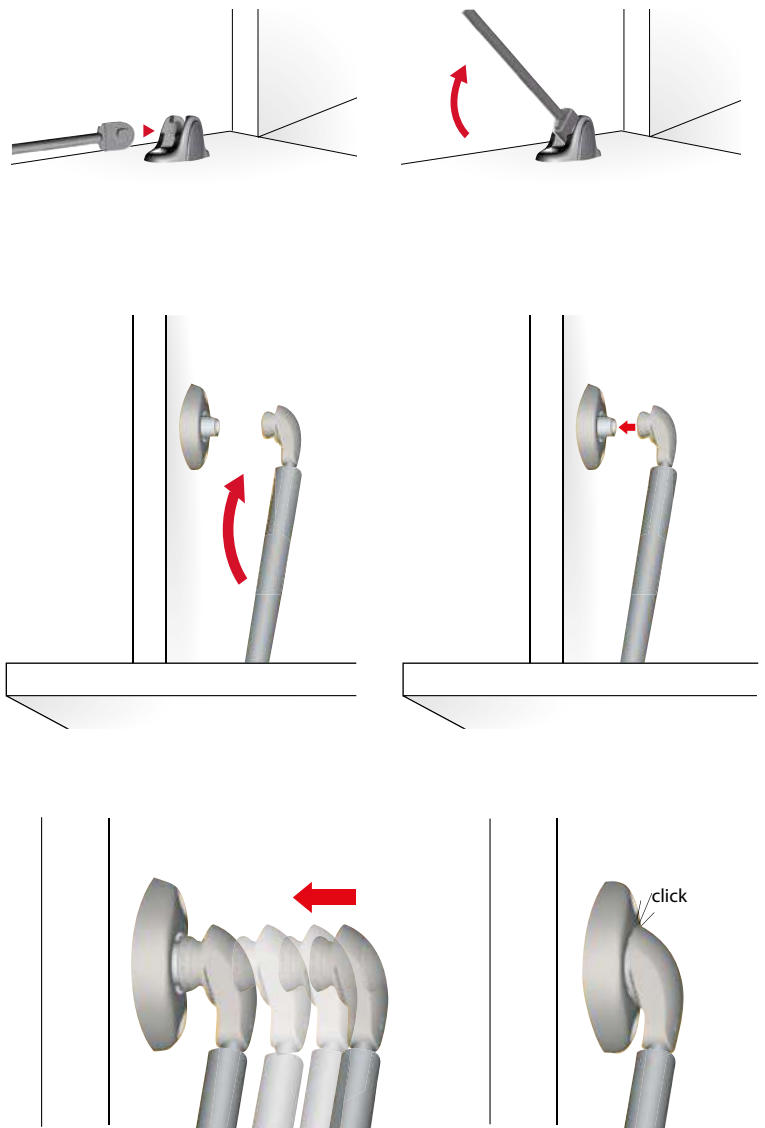
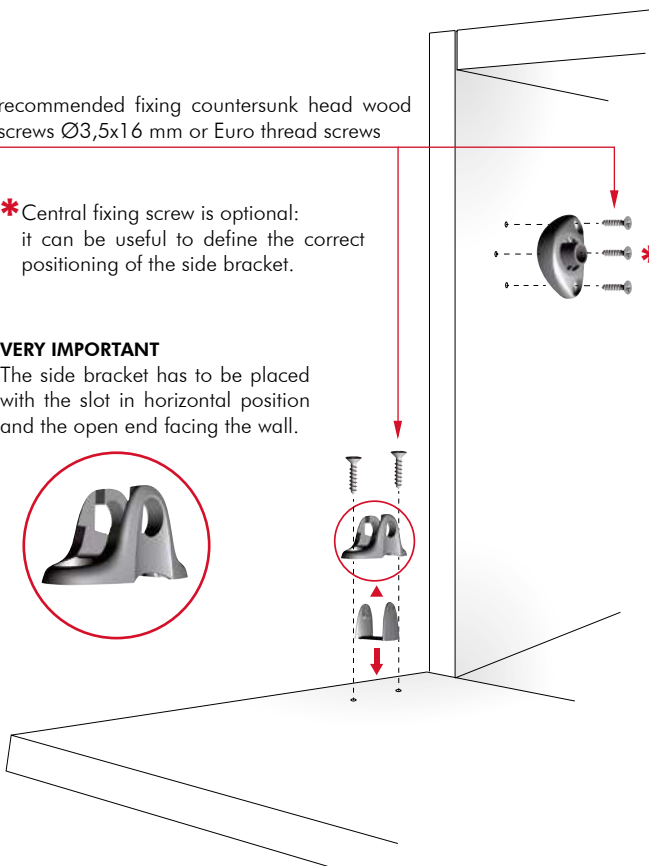



## DROP DOWN

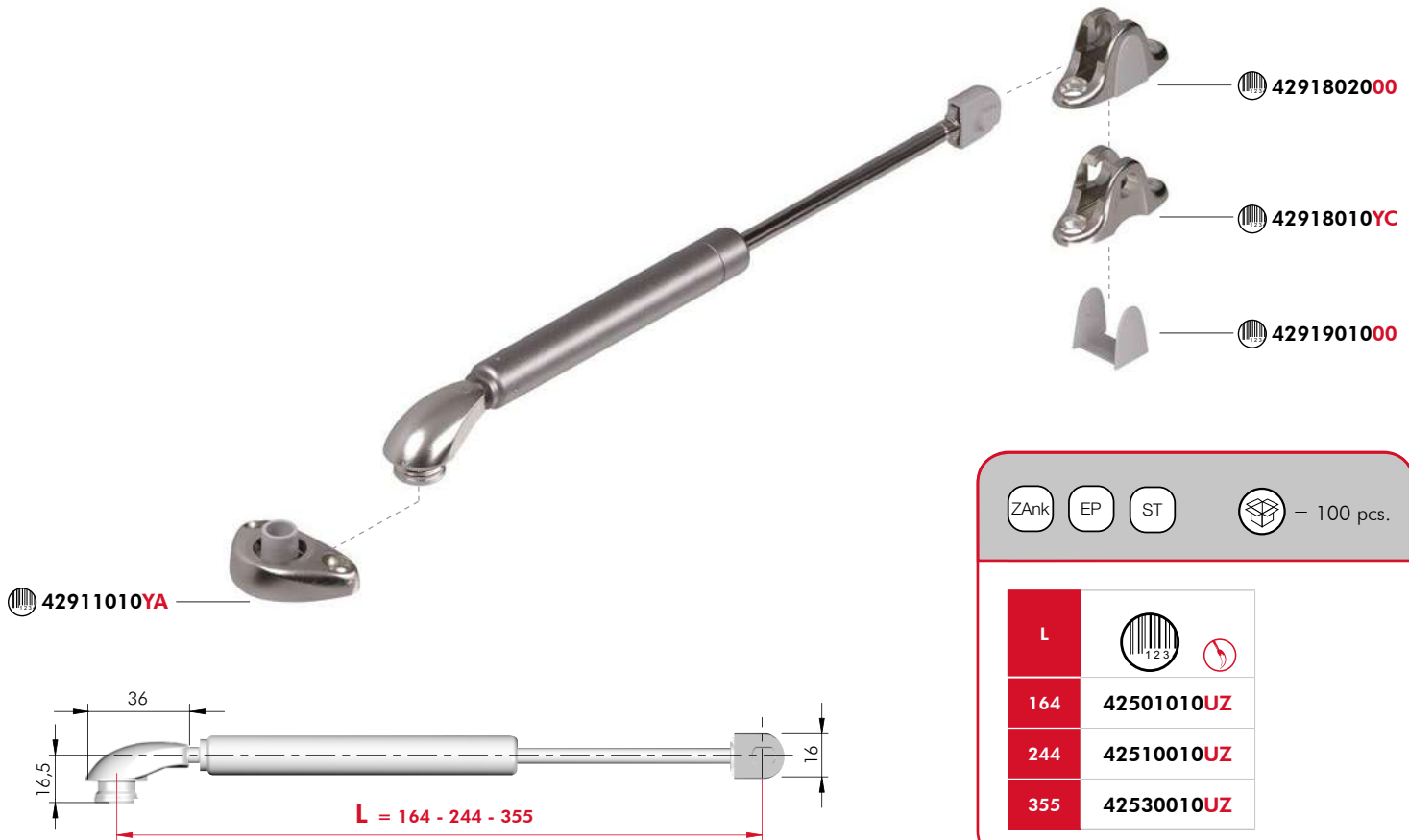

ZAnk EP ST = 100 pcs.

L	
164	42501010UZ
244	42510010UZ
355	42530010UZ

### Number of stays chart - L 164 mm

Rev. 02

h	Door weight (Kg)					
	1	2	3	4	5	6
200 - 284	2 x Compact		3 x Compact		4 x Compact	

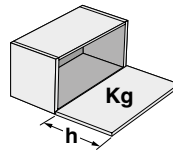

### Number of stays chart - L 244 mm

Rev. 02

h	Door weight (Kg)												
	1	2	3	4	5	6	7	8	9	10	11	12	13
280 - 324	2 x Compact						3 x Compact					4 x Compact	
325 - 424	2 x Compact						3 x Compact					4 x Compact	
425 - 500	2 x Compact						3 x Compact					4 x Compact	

### Number of stays chart - L 355 mm

Rev. 02

h	Door weight (Kg)												
	1	2	3	4	5	6	7	8	9	10	11	12	13
380 - 500	2 x Compact											3 x Compact	
501 - 600	2 x Compact											3 x Compact	

These are experimental results to be checked by the customer. **In accordance with the actual European regulation, we suggest to use at least two stays for each door.** Our technical department is at your disposal to test further cases out of this chart.



## DROP DOWN DRILLING PLANS WITH KIMANA HINGE

### L 164 mm



Magnet K Lock  
visible or invisible



K Push Tech 20 mm  
- With magnet  
- Visible or invisible

For details refer to section  
"PUSH CATCHES & MAGNETIC CATCHES".

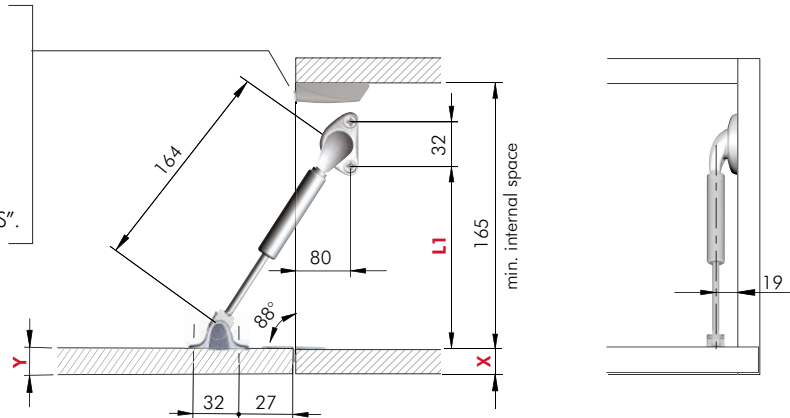

Cabinet (X)		Door (Y)		L1
16 mm	4 mm	16 mm	2 mm	117
16 mm	4 mm	19 mm	-	119
18 mm	2 mm	18 mm	-	117
19 mm	-	16 mm	2 mm	113
19 mm	-	19 mm	-	115
20 mm	-	20 mm	-	115

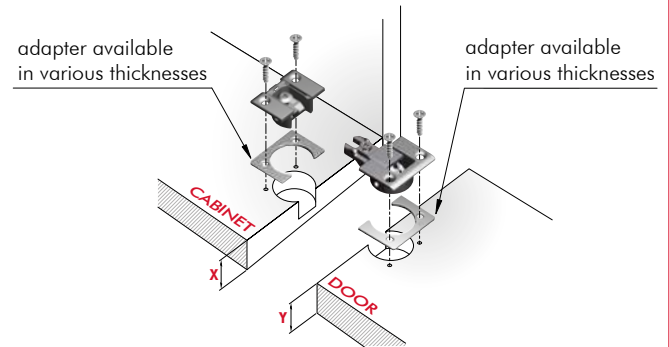

For Kimana and adapter details refer to section "HINGES".

### L 244 mm



Magnet K Lock  
visible or invisible



K Push Tech 20 mm  
- With magnet  
- Visible or invisible

For details refer to section  
"PUSH CATCHES & MAGNETIC CATCHES".

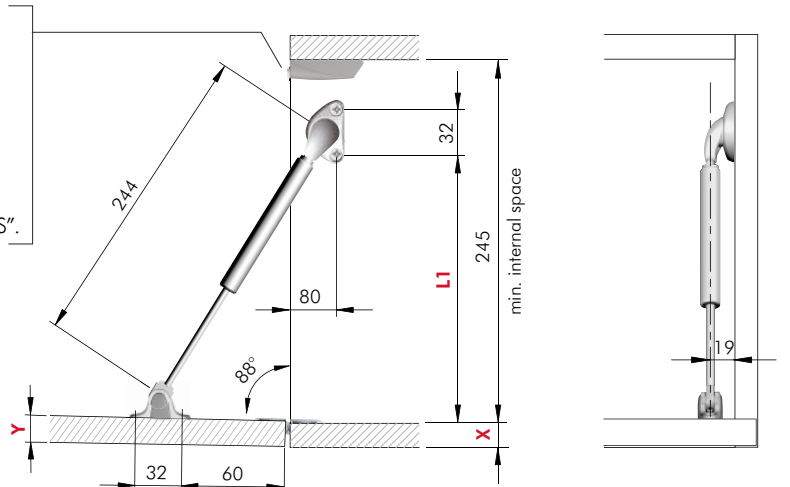

Cabinet (X)		Door (Y)		L1
16 mm	4 mm	16 mm	2 mm	197
16 mm	4 mm	19 mm	-	199
18 mm	2 mm	18 mm	-	197
19 mm	-	16 mm	2 mm	193
19 mm	-	19 mm	-	195
20 mm	-	20 mm	-	195

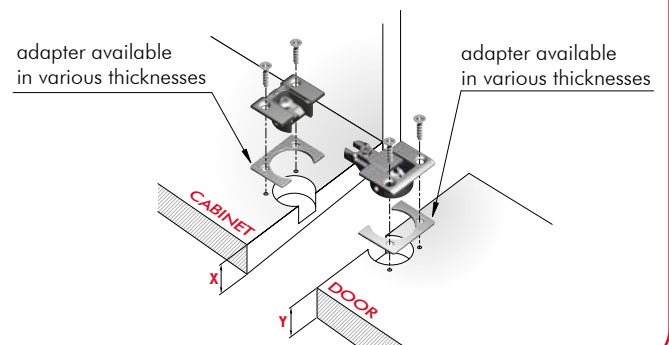

For Kimana and adapter details refer to section "HINGES".



L 355 mm



Magnet K Lock  
visible or invisible



K Push Tech 20 mm  
- With magnet  
- Visible or invisible

For details refer to section  
"PUSH CATCHES & MAGNETIC CATCHES".

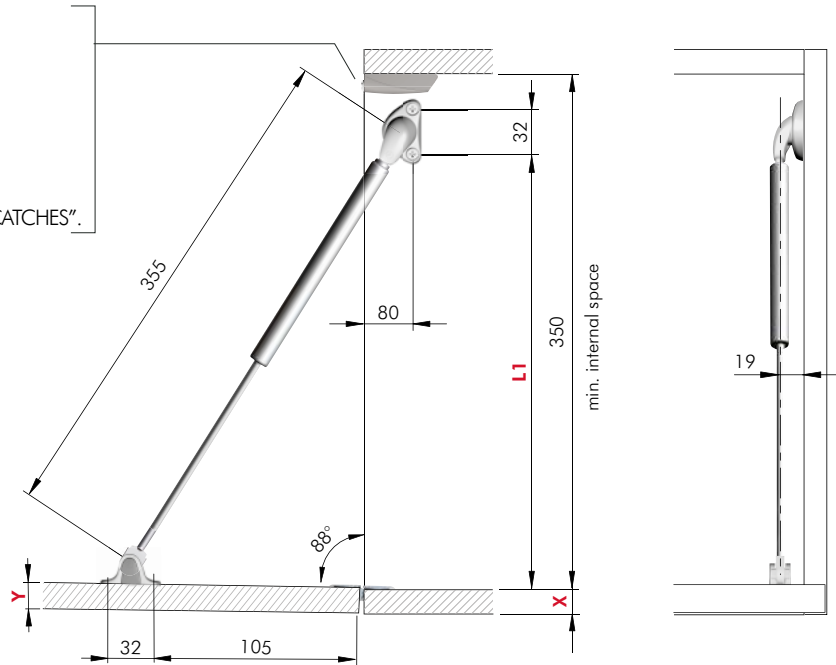

Cabinet (X)		Door (Y)		L1
16 mm	4 mm	16 mm	2 mm	302
16 mm	4 mm	19 mm	-	304
18 mm	2 mm	18 mm	-	302
19 mm	-	16 mm	2 mm	298
19 mm	-	19 mm	-	300
20 mm	-	20 mm	-	300

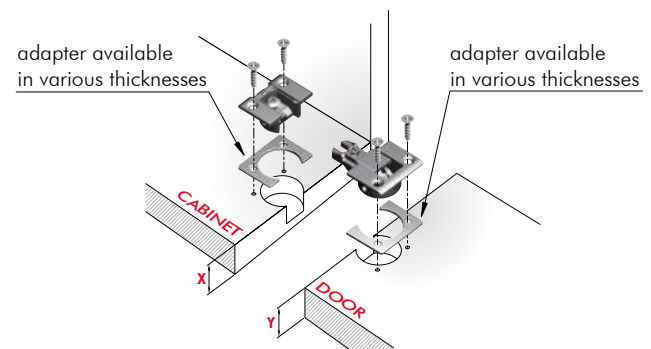

For Kimana and adapter details refer to section "HINGES".



## DROP DOWN DRILLING PLANS WITH STANDARD HINGES OPENING WITH HANDLE

COMPACT CONFIGURATOR:

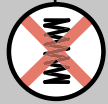
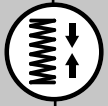
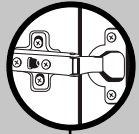
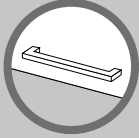

L 164 mm

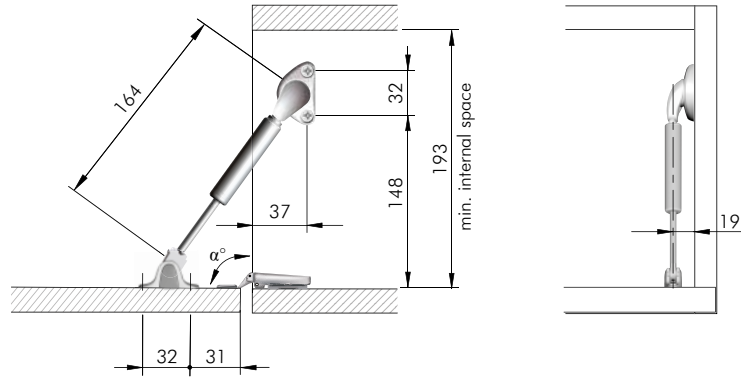

L 244 mm

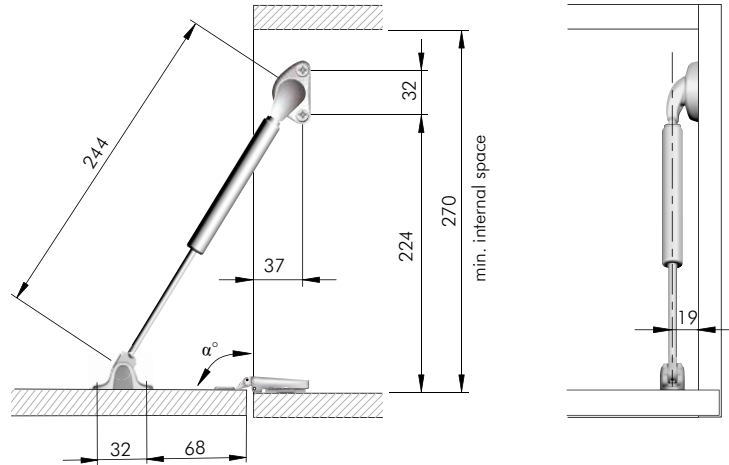

L 355 mm

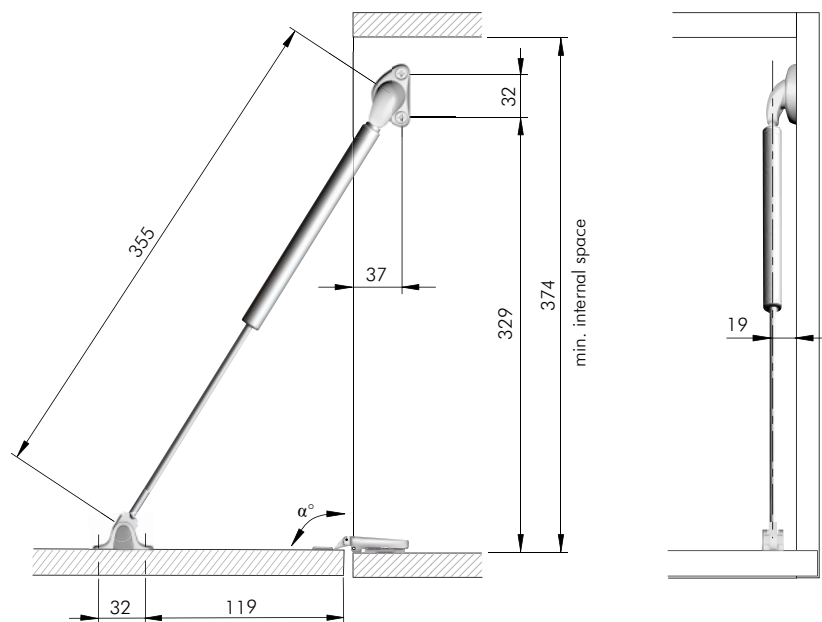

The dimensions of the drilling plans refer to carcasses which use *standard sprung hinges* and mounting plates 0 mm. Please note that the  $\alpha^\circ$  opening angle shown data is purely indicative. It varies with respect to the hinge brand and adjustment carried out.



Please note that in case of use of **unsprung hinges**, **magnet K Lock** is required. For details refer to section "PUSH CATCHES & MAGNETIC CATCHES".



## DROP DOWN DRILLING PLANS WITH STANDARD HINGES PUSH TO OPEN

COMPACT CONFIGURATOR:

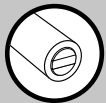
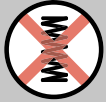
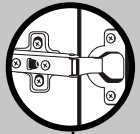

L 164 mm

K Push Tech 14 mm  
- With magnet  
- Visible or invisible

For details refer to section  
"PUSH CATCHES & MAGNETIC CATCHES".

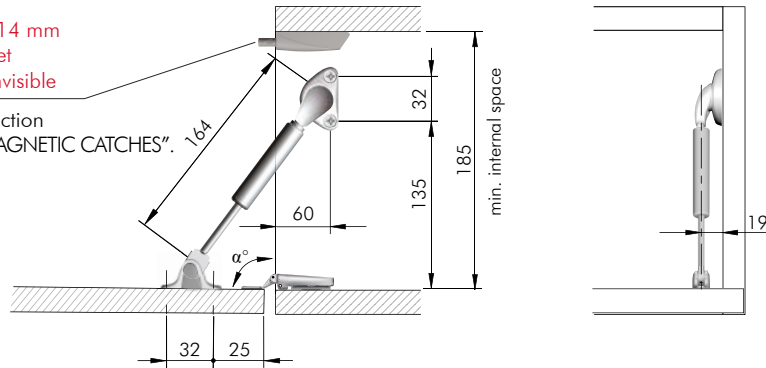

L 244 mm

K Push Tech 14 mm  
- With magnet  
- Visible or invisible

For details refer to section  
"PUSH CATCHES & MAGNETIC CATCHES".

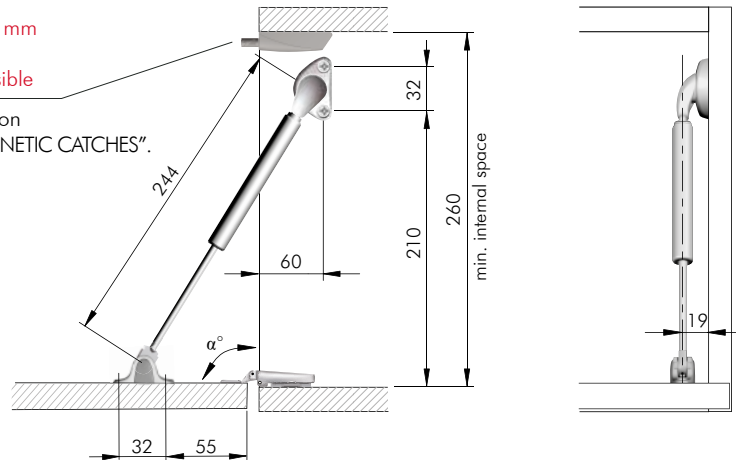

L 355 mm

K Push Tech 14 mm  
- With magnet  
- Visible or invisible

For details refer to section  
"PUSH CATCHES & MAGNETIC CATCHES".

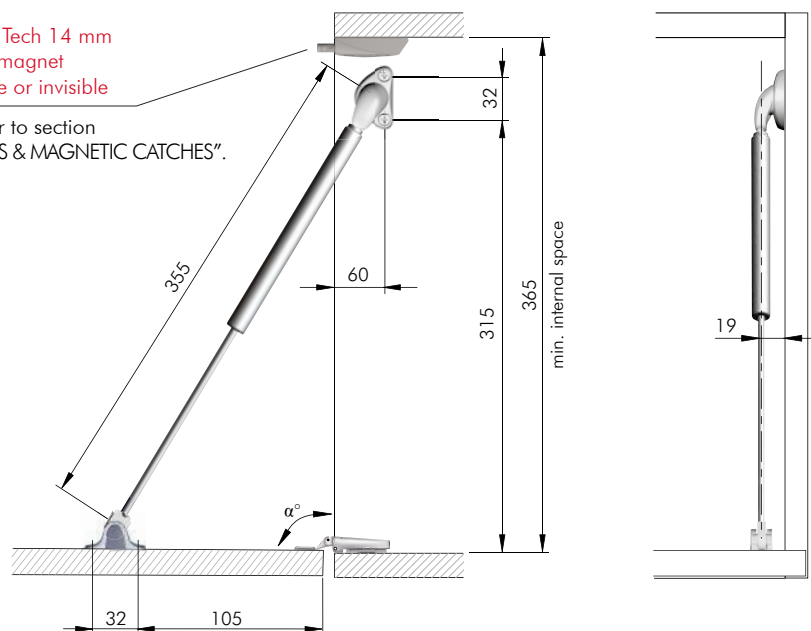

The dimensions of the drilling plan refer to carcasses which use **standard unsprung hinges** and mounting plates 0 mm. Please note that the  $\alpha^\circ$  opening angle shown data is purely indicative. It varies with respect to the hinge brand and adjustment carried out.

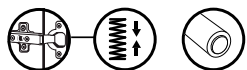

Please note that utilization with **standard sprung hinges** and **K Push Tech with buffer** is also possible. In such case, after the door is initially released by K Push Tech, a manual opening approx. 7cm is required (in order to win the spring resistance). Consequently, the door will automatically open to the fullest. For details refer to section "PUSH CATCHES & MAGNETIC CATCHES".



## DROP DOWN DRILLING PLANS WITH FLAP HINGE

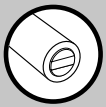
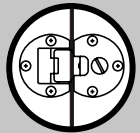
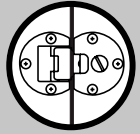
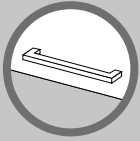

### L 164 mm



Magnet K Lock  
visible or invisible



K Push Tech 20 mm  
- With magnet  
- Visible or invisible

For details refer to section  
"PUSH CATCHES & MAGNETIC CATCHES".

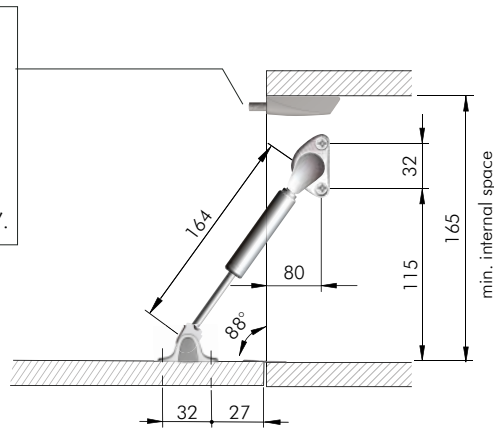

### L 244 mm



Magnet K Lock  
visible or invisible



K Push Tech 20 mm  
- With magnet  
- Visible or invisible

For details refer to section  
"PUSH CATCHES & MAGNETIC CATCHES".

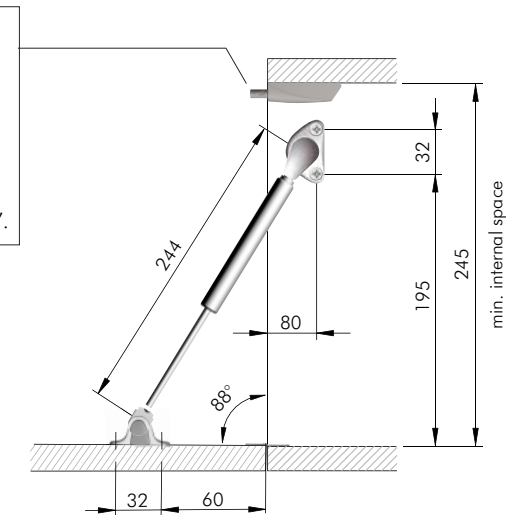

### L 355 mm



Magnet K Lock  
visible or invisible



K Push Tech 20 mm  
- With magnet  
- Visible or invisible

For details refer to section  
"PUSH CATCHES & MAGNETIC CATCHES".

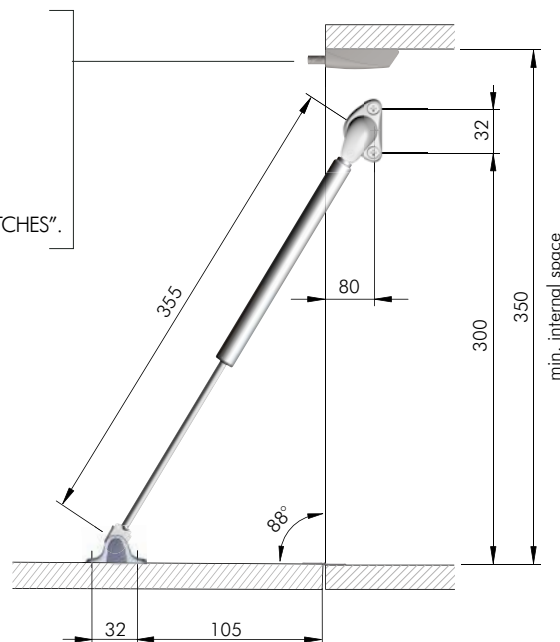

The dimensions of the drilling plan refer to carcasses which use **standard flap hinges**.





## COMPACT BRACKETS

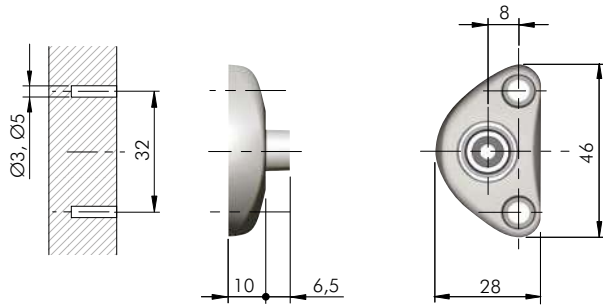

= Ø 3, Ø 5 mm

ZA EP

= 100 pcs.



**42911010YA**

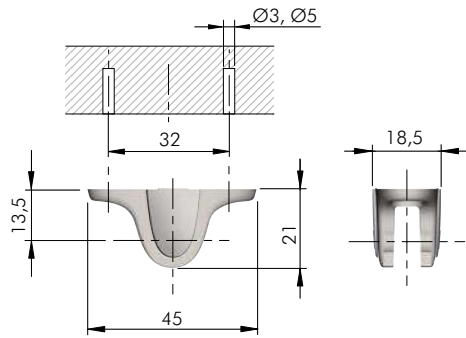

= Ø 3, Ø 5 mm

ZA

= 100 pcs.



**4291802000**

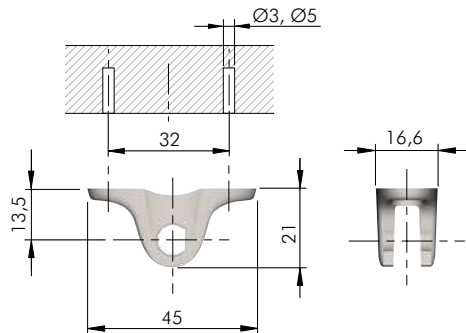

= Ø 3, Ø 5 mm

ZA

= 100 pcs.



**42918010YC**

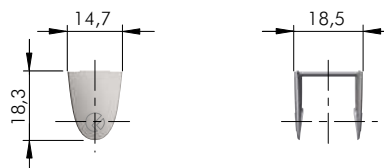

EPg

= 100 pcs.



**4291901000**

## COMPACT FIXING ACCESSORIES

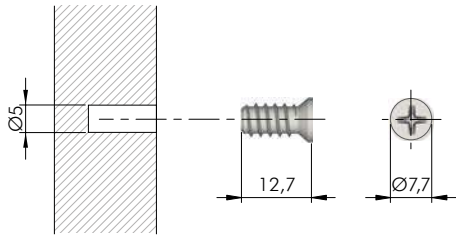

	= Ø 5 mm		
			= PZ2
ST		= 5000 pcs.	
<b>60501050YA</b>			

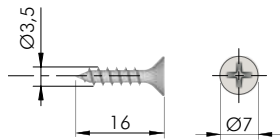

	= Ø 2,5 mm		
			= PZ2
ST		= 10.000 pcs.	
<b>60101390YA</b>			



## COMPACT ADAPTERS FOR ALUMINIUM FRAME DOOR

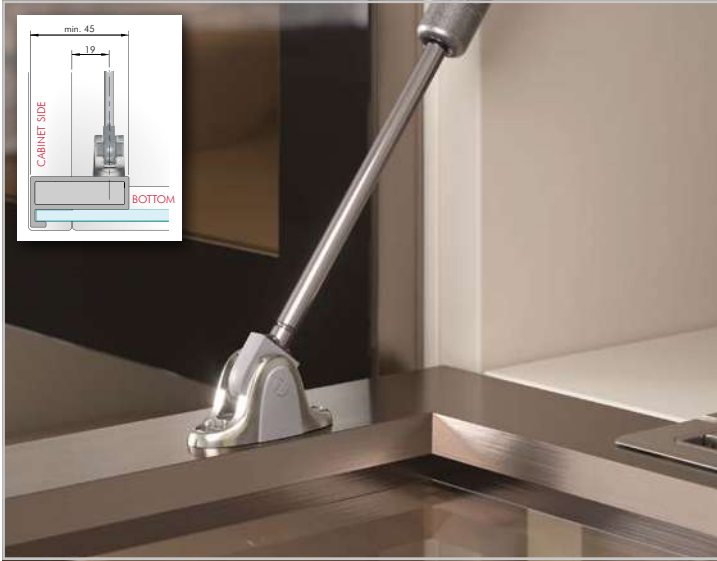

INSTALLATION ON WIDER ALUMINIUM FRAME DOOR



INSTALLATION ON NARROW ALUMINIUM FRAME DOOR

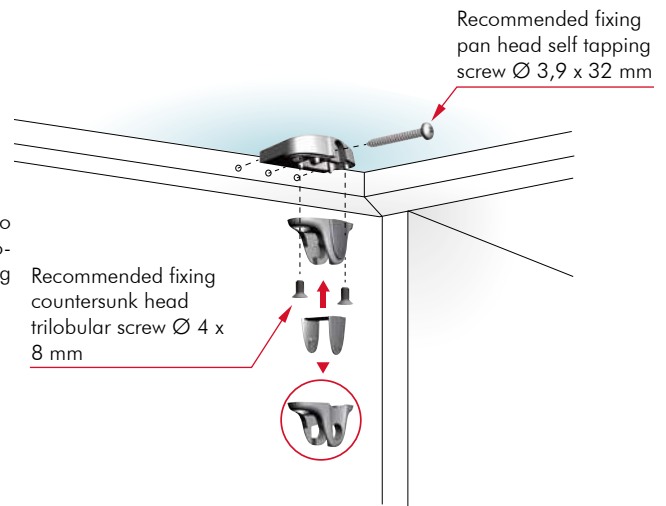
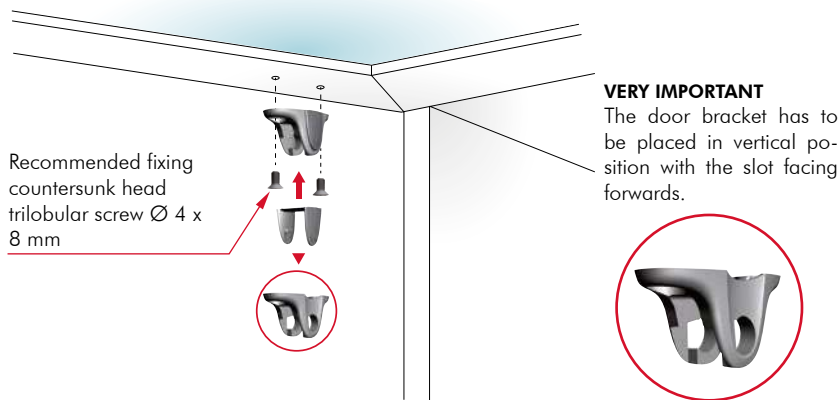

### WIDER ALUMINIUM FRAME DOOR

Condition A

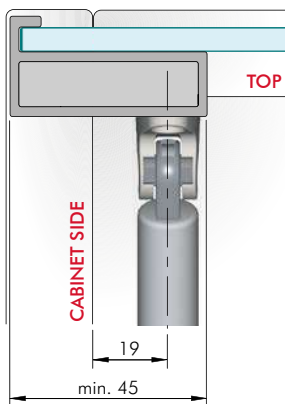

Assembling

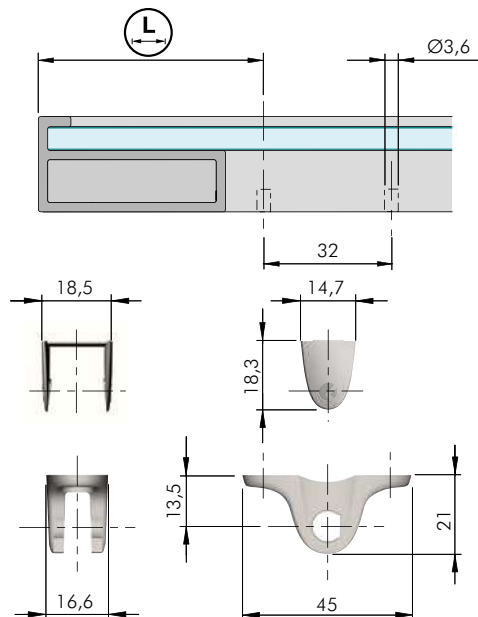

=  $\varnothing 3,6$  mm

ZA EP

= 100 pcs.



42918010YC

4291901000



# OPENING SYSTEMS FOR LIFT UP AND DROP DOWN DOORS

## NARROW ALUMINIUM FRAME DOOR

### Condition B

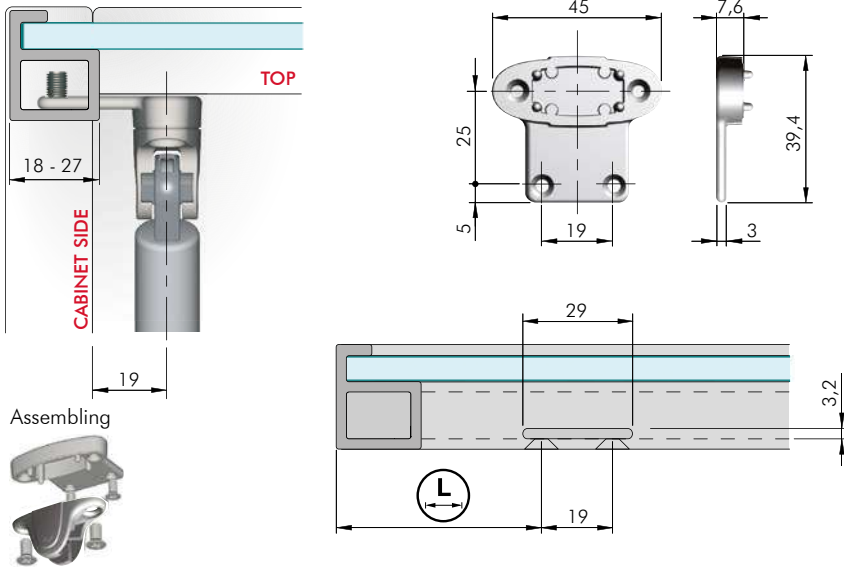

ZA

= 100 pcs.



42903010YC



42918010YC



4291901000



### Condition C

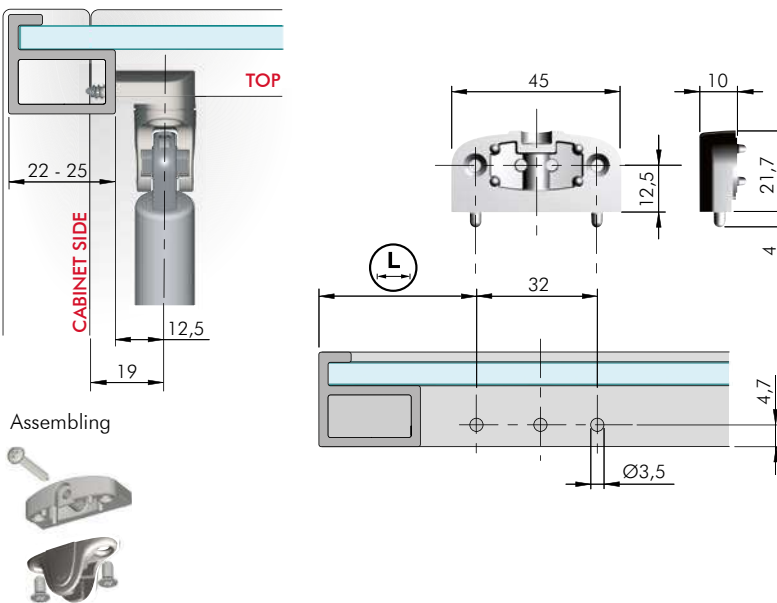

=  $\varnothing 3,5$  mm

ZA

= 100 pcs.



42904010YC



42918010YC



4291901000



### Condition D

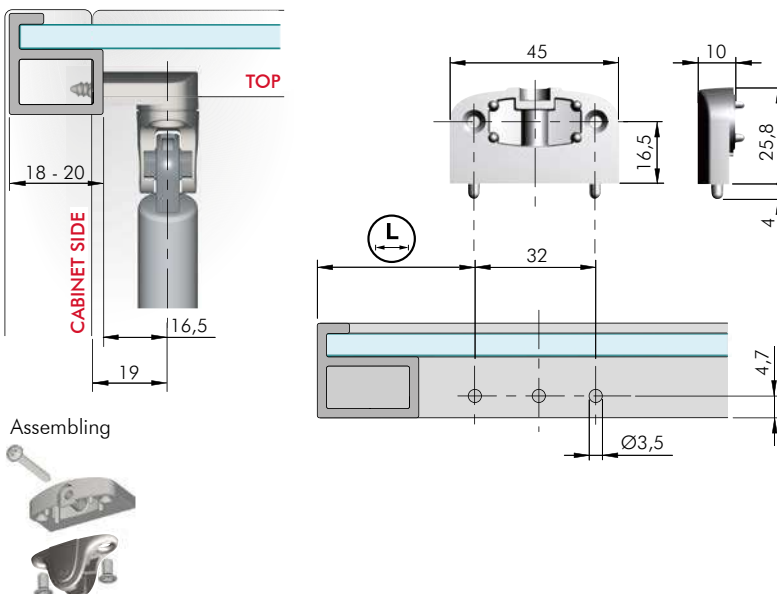

=  $\varnothing 3,5$  mm

ZA

= 100 pcs.



42905010YC



42918010YC



4291901000



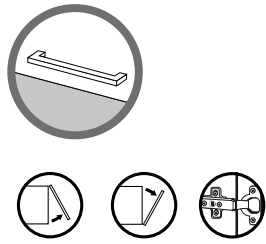

COMPACT	L	
164	31	37,5
244	68	74,5
355	119	125,5

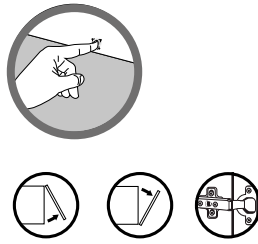

COMPACT	L	
164	25	31,5
244	55	61,5
355	105	111,5

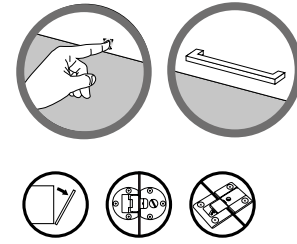

COMPACT	L	
164	27	33,5
244	60	66,5
355	105	111,5

For details refer to related sections.

## ALUMINIUM ADAPTERS FIXING ACCESSORIES



= PZ2

ST

= on request

123

**42906010YA**

For wider aluminium frame and for condition A, B, C, D.

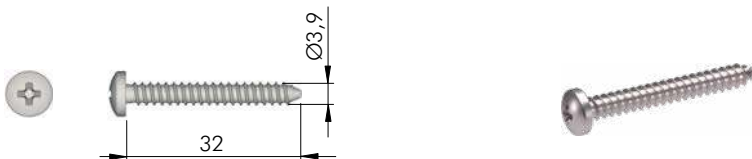

= PZ2

ST

= on request

123

**60203410YA**

For condition C and D.



## K12 SYSTEM LIFT UP



REGISTERED DESIGN  
Certificates available on request.



### BRACKET Ø15 INSTALLATION

- For details refer to "K12 SYSTEM BRACKETS".

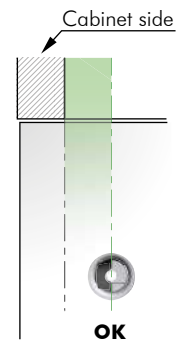
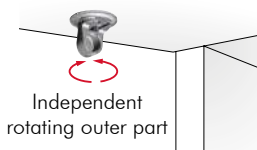

**VERY IMPORTANT**  
The door bracket has to be aligned with the cabinet side.

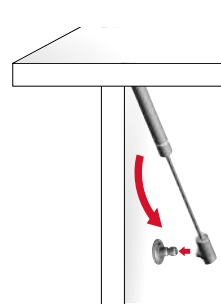
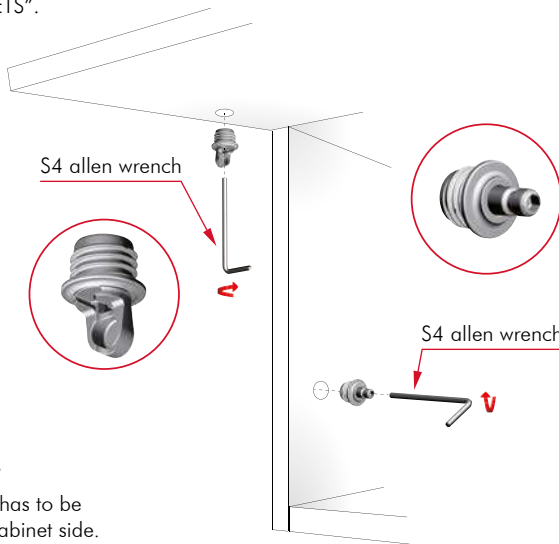

8

### SCREW FIXING BRACKETS INSTALLATION

- For details refer to "K12 SYSTEM BRACKETS".

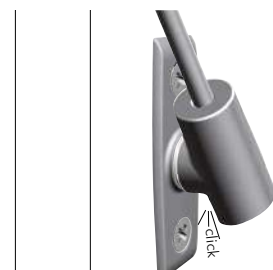
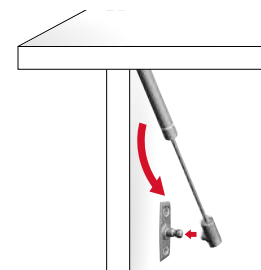
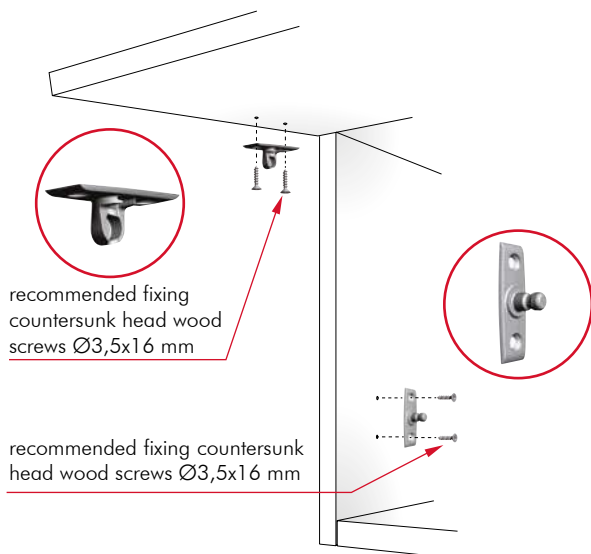



## K12 SYSTEM ADJ LIFT UP

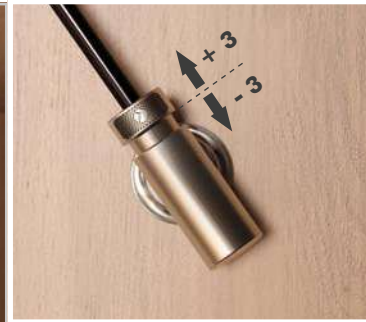

Certificates available on request.



### INSTALLATION

- For details refer to "K12 SYSTEM ADJ BRACKETS".

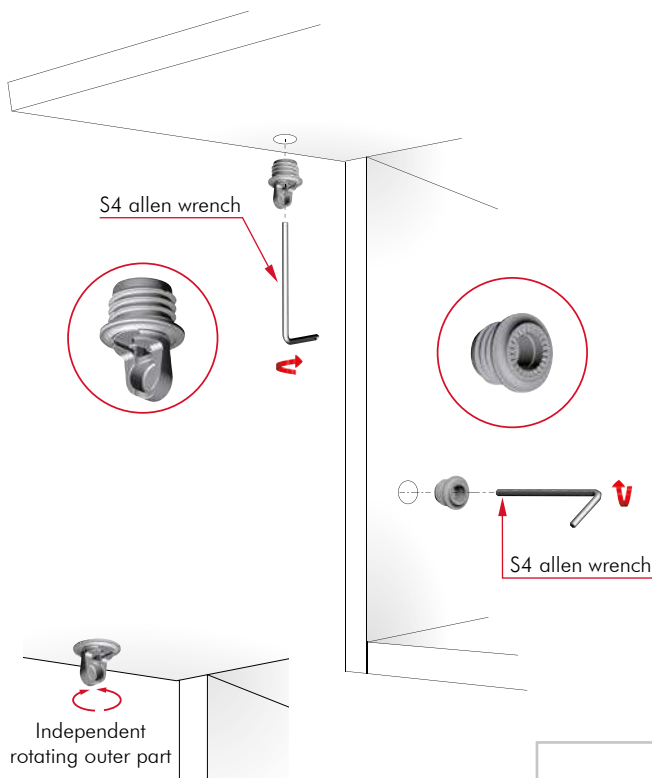

**LOCKING:** Rotate the plastic knob.

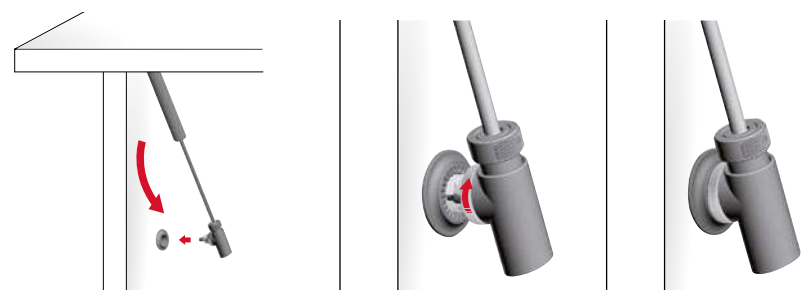

8

### ADJUSTMENT

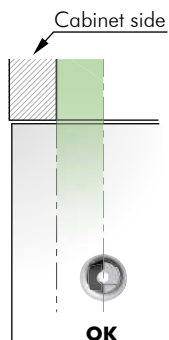
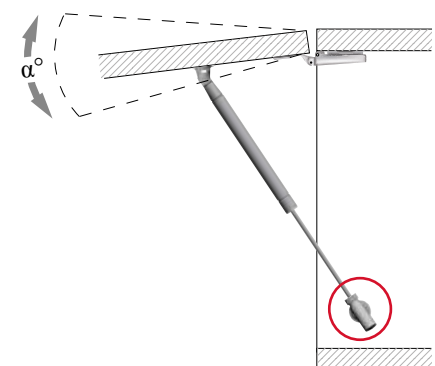
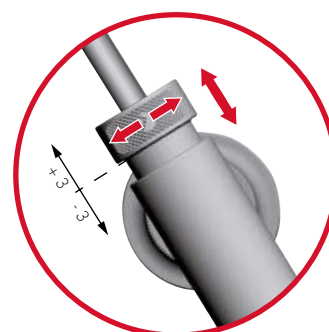

**VERY IMPORTANT**  
The door bracket has to be aligned with the cabinet side.



## K12 SYSTEM LIFT UP

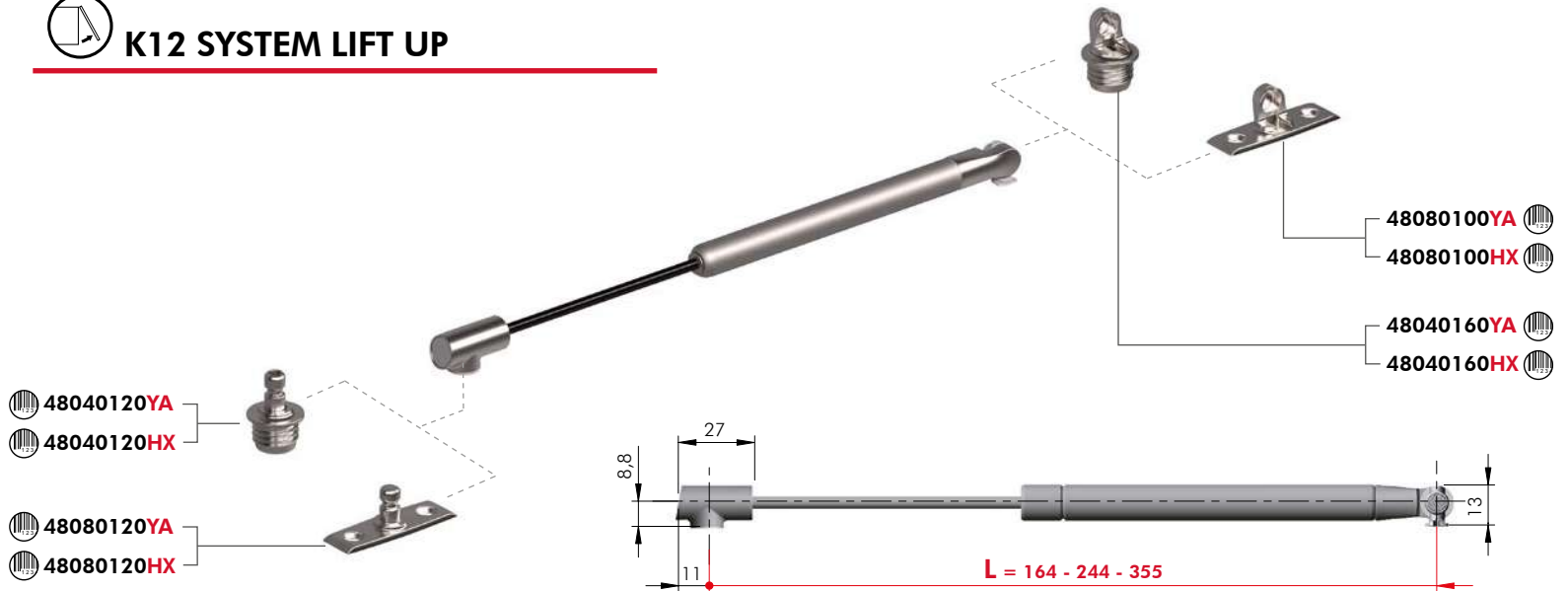

## K12 SYSTEM ADJ LIFT UP

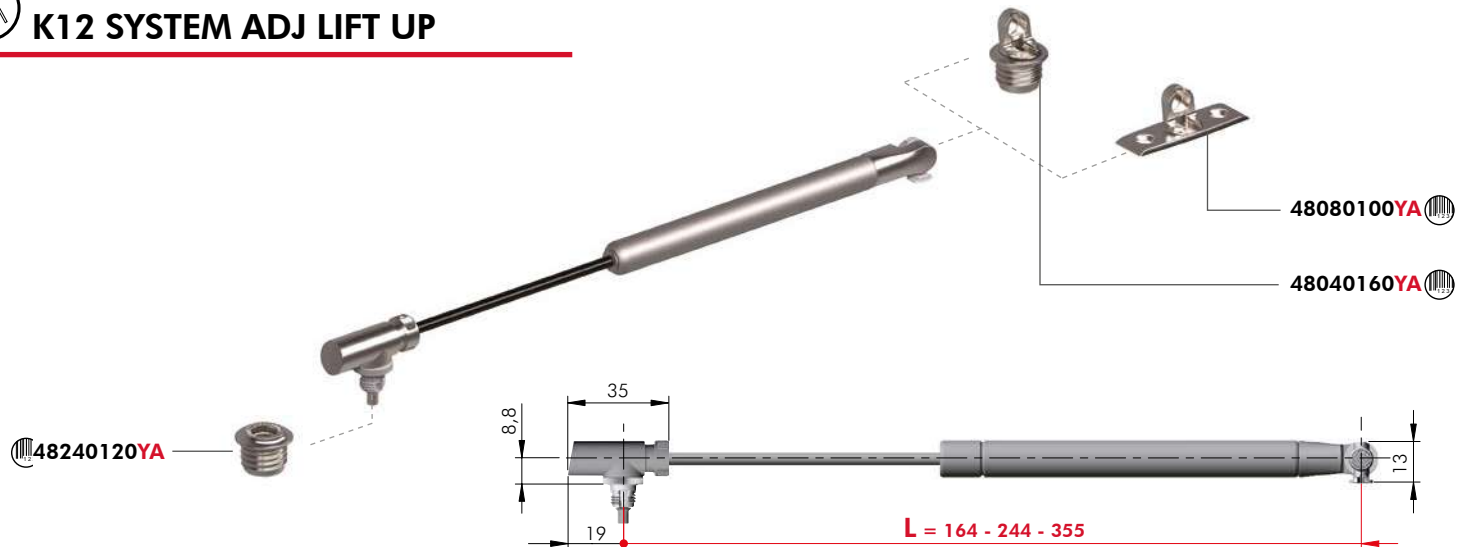

8

ZA EP ST

= 100 pcs. for L. 164 mm  
50 pcs. for L. 244 and 355 mm

L	K12 SYSTEM		K12 SYSTEM ADJ		N	L	K12 SYSTEM		K12 SYSTEM ADJ		N	L	K12 SYSTEM		K12 SYSTEM ADJ		N
164	48010420UZ		48210420UZ		50	244	48020420UZ		48220420UZ		50	355	48030430UZ		48230430UZ		60
	48010460UZ		48210460UZ		80		48020460UZ		48220460UZ		80		48030470UZ		48230470UZ		90
	48010500UZ		48210500UZ		100		48020480UZ		48220480UZ		100		48030490UZ		48230490UZ		110
	48010540UZ		48210540UZ		120		48020500UZ		48220500UZ		120		+  Part.no + HX				
	+  Part.no + HX					48020540UZ		48220540UZ		140							

+ Part.no + HX = K12 System with end parts in graphite finish are available on request.

Further newton strengths available on request.





## Number of stays chart - L 164 mm

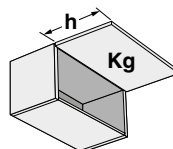

Rev. 02

h	Door weight (Kg)															
	1	1,5	2	2,5	3	3,5	4	4,5	5	5,5	6	6,5	7	7,5	8	8,5
200 - 224	2x50N		2x80N		2x100N			2x120N		3x120N		4x100N		4x120N		
225 - 274	2x50N		2x80N		2x100N			2x120N		3x120N		4x100N		4x120N		
275 - 300	2x50N		2x80N		2x100N		2x120N		3x100N		3x120N		4x100N		4x120N	

## Number of stays chart - L 244 mm

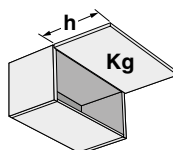

Rev. 02

h	Door weight (Kg)																								
	1	1,5	2	2,5	3	3,5	4	4,5	5	5,5	6	6,5	7	7,5	8	8,5	9	9,5	10	10,5	11	11,5	12	12,5	13
290 - 324	1x50N	1x80N		2x50N		2x80N						2x100N		2x120N		2x140N		2x160N*		2x180N*					
325 - 374	1x50N	1x80N	2x50N		2x80N						2x100N		2x120N		2x140N		2x160N*		2x180N*						
375 - 424	1x50N	1x80N	2x50N		2x80N				2x100N		2x120N		2x140N		2x160N*		2x180N*				3x140N				
425 - 474	1x50N	2x50N		2x80N				2x100N		2x120N		2x140N		2x160N*		2x180N*				3x160N*		3x180N*			
475 - 500	1x50N	2x50N		2x80N		2x100N		2x120N		2x140N		2x160N*		2x180N*		3x160N*				3x180N*					

\* Streights available on request.

## Number of stays chart - L 355 mm

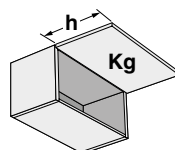

Rev. 02

h	Door weight (Kg)																								
	1	1,5	2	2,5	3	3,5	4	4,5	5	5,5	6	6,5	7	7,5	8	8,5	9	9,5	10	10,5	11	11,5	12	12,5	13
390 - 424	1x60N		1x90N		2x60N				2x90N				2x110N				3x90N								
425 - 474	1x60N		1x90N		2x60N				2x90N				2x110N				3x90N				3x110N				
475 - 524	1x60N		1x90N		2x60N				2x90N				2x110N				3x90N				3x110N		4x90N		
525 - 574	1x60N		1x90N		2x60N		2x90N				2x110N		3x90N				3x110N				4x90N		4x110N		
575 - 600	1x90N		2x60N		2x90N		2x110N				3x90N				3x110N				4x90N		4x110N				

These are experimental results to be checked by the customer. Our Technical Department is at your disposal to test further cases out of this chart.



## LIFT UP DRILLING PLANS WITH STANDARD HINGES OPENING WITH HANDLE

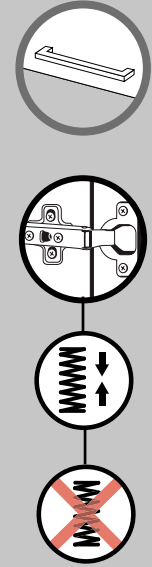

L 164 mm

Opening angle adjustment is possible only with K12 SYSTEM ADJ version.

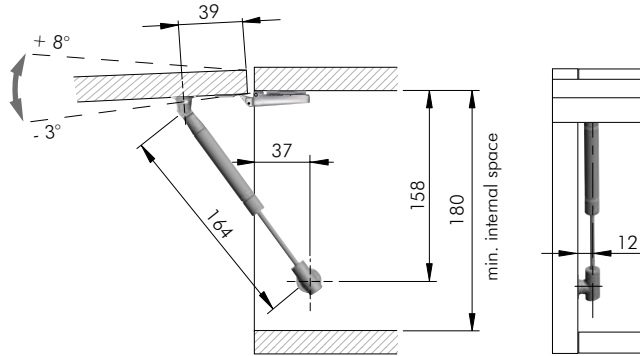

SCREW FIXING BRACKETS:

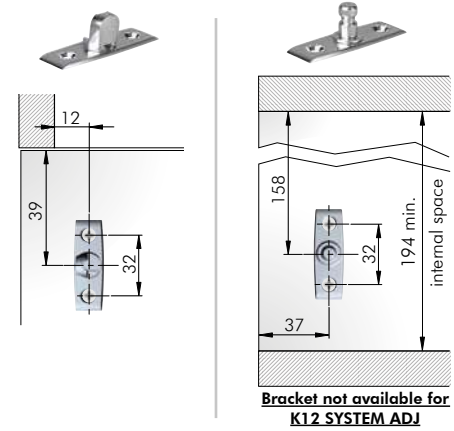

L 244 mm

Opening angle adjustment is possible only with K12 SYSTEM ADJ version.

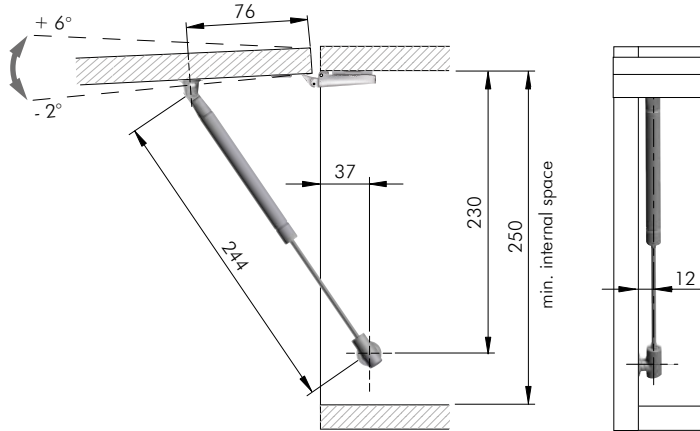

SCREW FIXING BRACKETS:

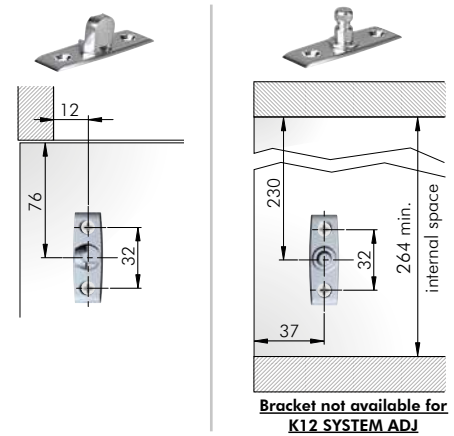

L 355 mm

Opening angle adjustment is possible only with K12 SYSTEM ADJ version.

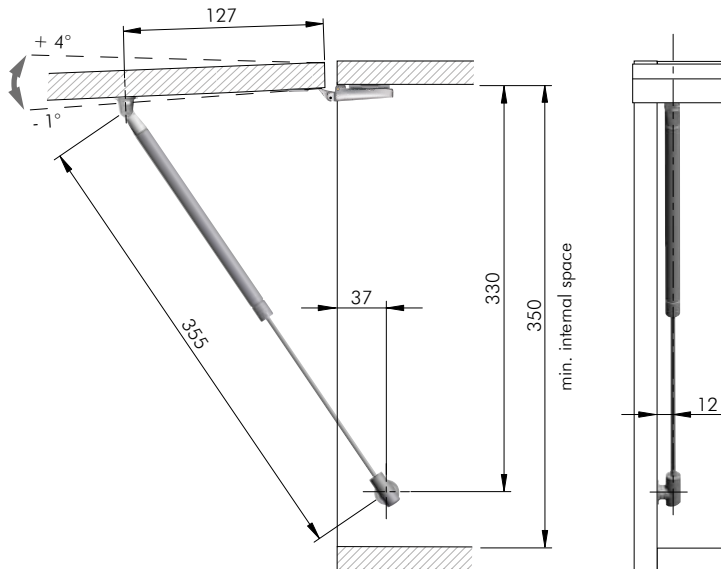

SCREW FIXING BRACKETS:

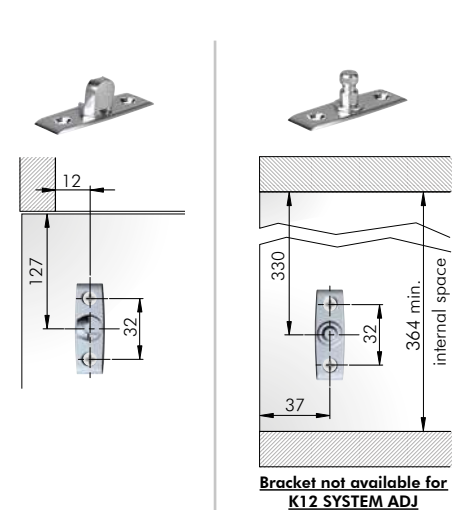

The dimensions of the above drilling plans refer to carcasses which use **standard sprung** or **unsprung hinges** and mounting plates 0 mm. Please note that the opening angle varies with respect to the hinge brand and adjustment carried out.



Please note that in case of use of **unsprung hinges**, **magnet K Lock** is required. For details refer to section "PUSH CATCHES & MAGNETIC CATCHES".



## LIFT UP DRILLING PLANS WITH STANDARD HINGES PUSH TO OPEN

K12 SYSTEM CONFIGURATOR:

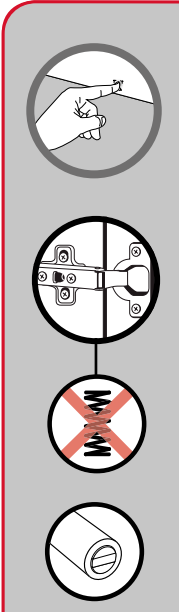

L 164 mm

**Opening angle adjustment** is possible only with K12 SYSTEM ADJ version.

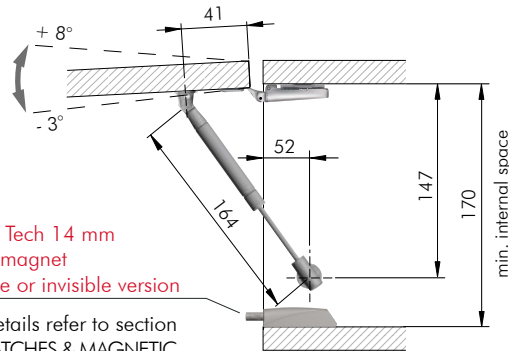

K Push Tech 14 mm  
- With magnet  
- Visible or invisible version

For details refer to section "PUSH CATCHES & MAGNETIC CATCHES".

SCREW FIXING BRACKETS:

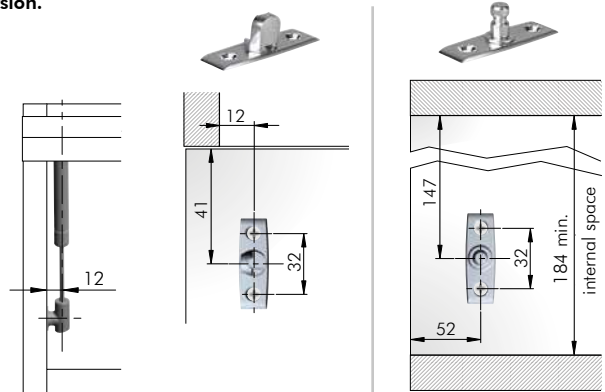

Bracket not available for K12 SYSTEM ADJ

L 244 mm

**Opening angle adjustment** is possible only with K12 SYSTEM ADJ version.

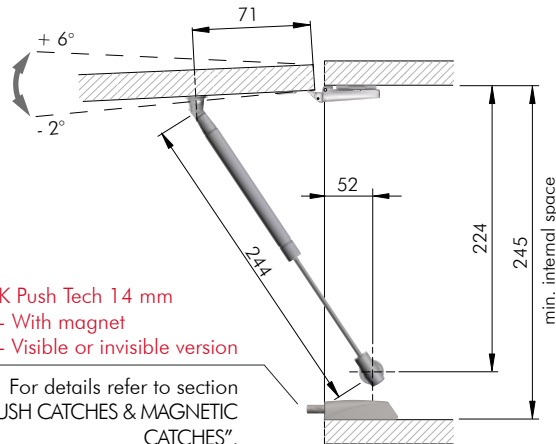

K Push Tech 14 mm  
- With magnet  
- Visible or invisible version

For details refer to section "PUSH CATCHES & MAGNETIC CATCHES".

SCREW FIXING BRACKETS:

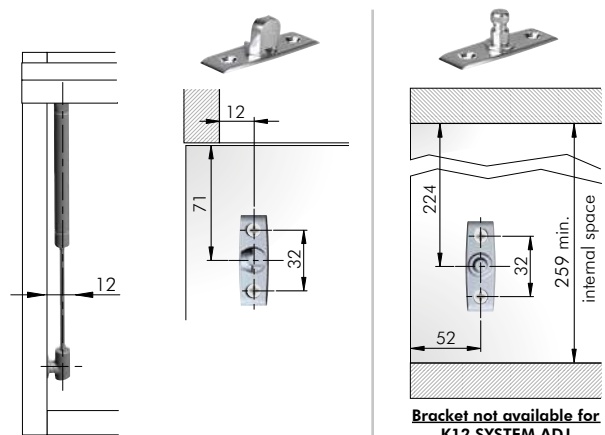

Bracket not available for K12 SYSTEM ADJ

L 355 mm

**Opening angle adjustment** is possible only with K12 SYSTEM ADJ version.

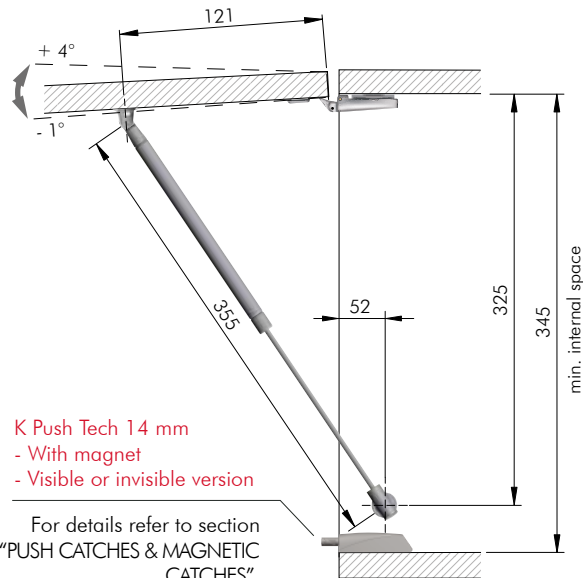

K Push Tech 14 mm  
- With magnet  
- Visible or invisible version

For details refer to section "PUSH CATCHES & MAGNETIC CATCHES".

SCREW FIXING BRACKETS:

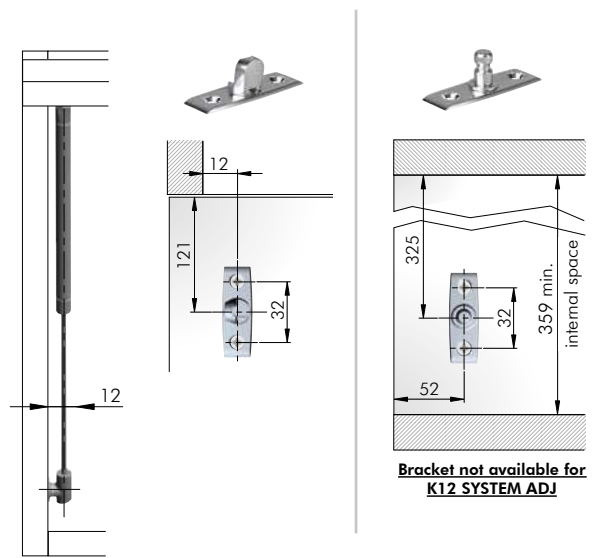

Bracket not available for K12 SYSTEM ADJ

The dimensions of the above drilling plan refer to carcasses which use **standard unsprung hinges** and mounting plates 0 mm. Please note that the opening angle varies with respect to the hinge brand and adjustment carried out.

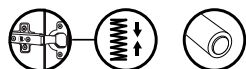

Please note that utilization with **standard sprung hinges** and **K Push Tech with buffer** is also possible. In such case, after the door is initially released by K Push Tech, a manual opening approx. 7cm is required (in order to win the spring resistance). Consequently, the door will automatically open to the fullest. For details refer to section "PUSH CATCHES & MAGNETIC CATCHES".

## K12 SYSTEM DROP DOWN



REGISTERED DESIGN   
Certificates available on request.

### BRACKET Ø15 INSTALLATION

- For details refer to "K12 SYSTEM BRACKETS".

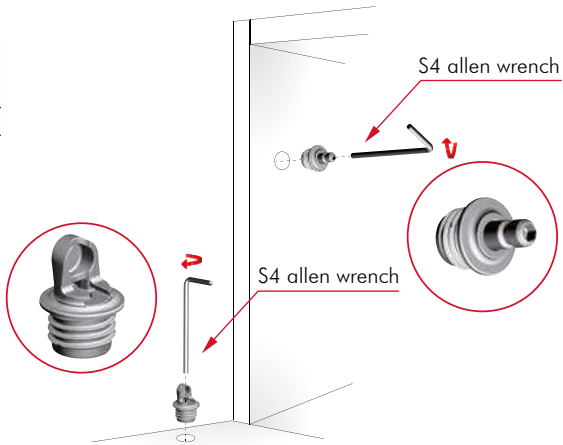
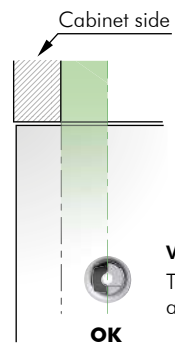
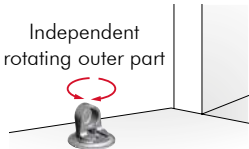

**VERY IMPORTANT**  
The door bracket has to be aligned with the cabinet side.

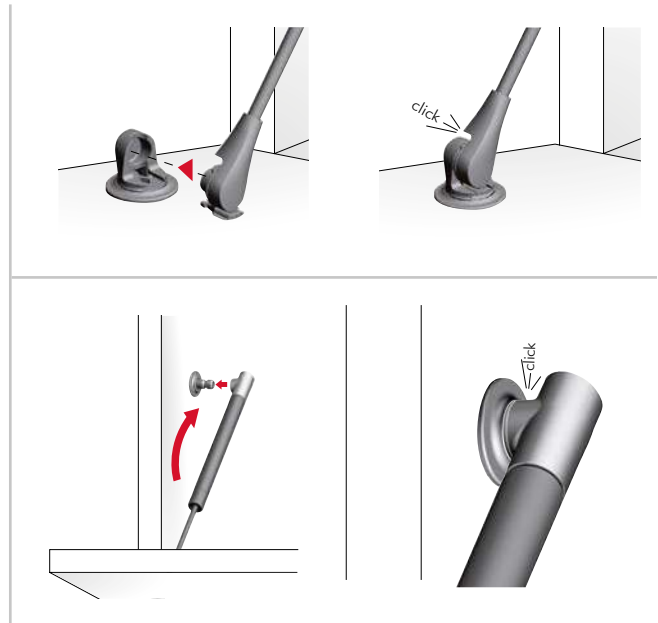

### SCREW FIXING BRACKETS INSTALLATION

- For details refer to "K12 SYSTEM BRACKETS".

recommended fixing countersunk head wood screws Ø3,5x16 mm

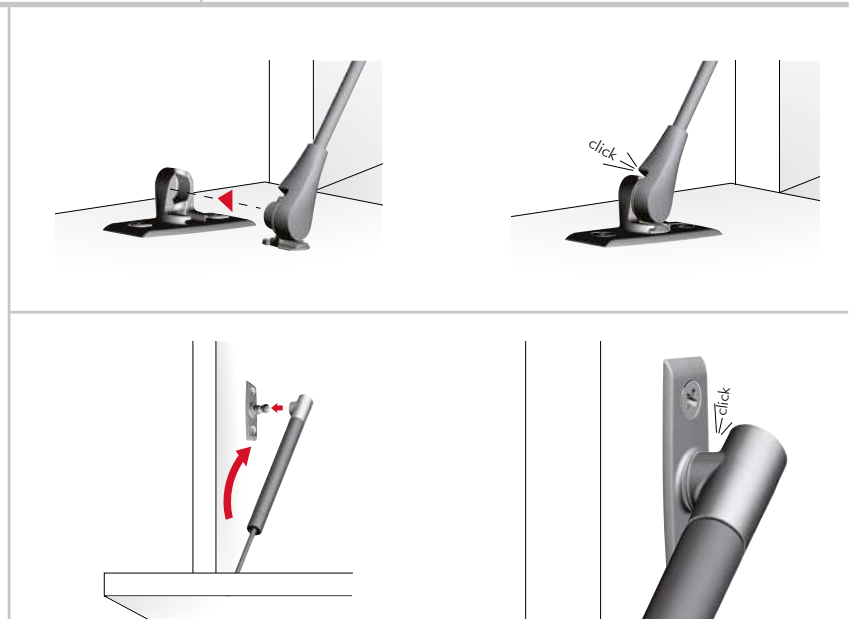
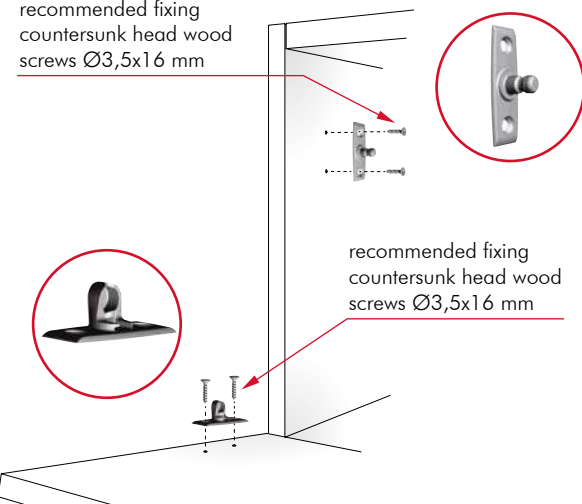

8



## K12 SYSTEM ADJ DROP DOWN

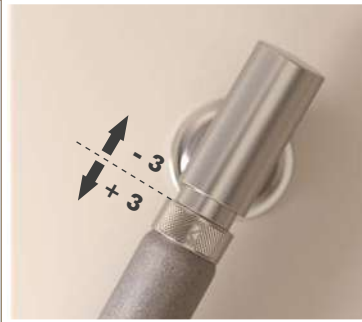

Certificates available on request.



### BRACKET Ø15 INSTALLATION

- For details refer to "K12 SYSTEM ADJ BRACKETS".

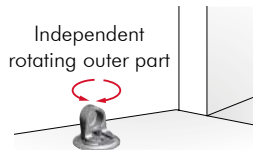
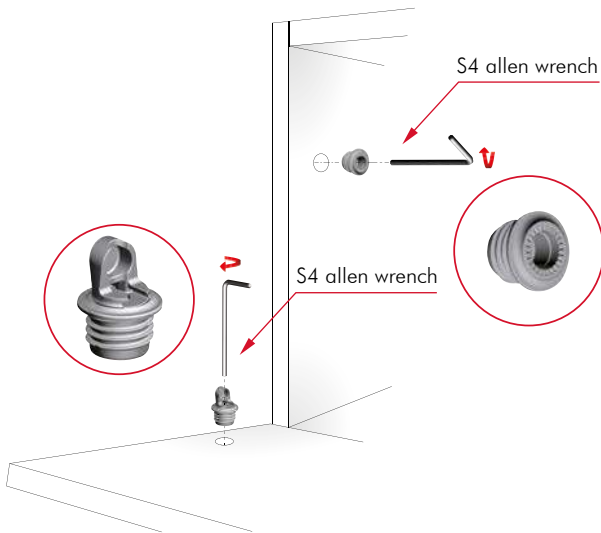

Cabinet side

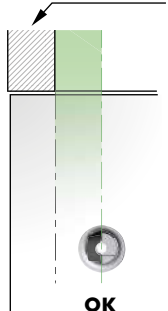

### VERY IMPORTANT

The door bracket has to be aligned with the cabinet side.



**LOCKING:** Rotate the plastic knob.

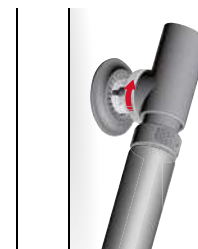
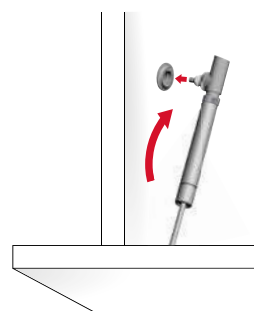

### ADJUSTMENT

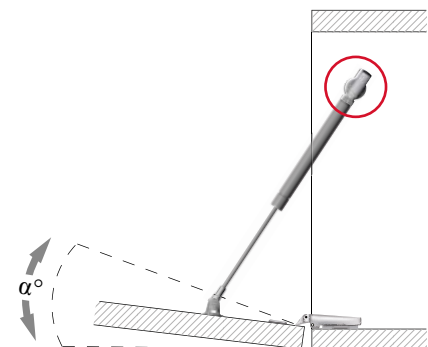
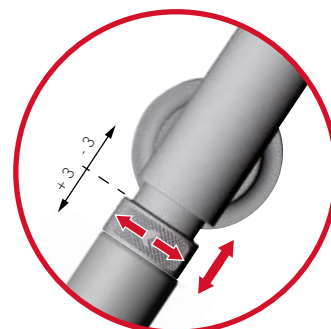



## K12 SYSTEM DROP DOWN

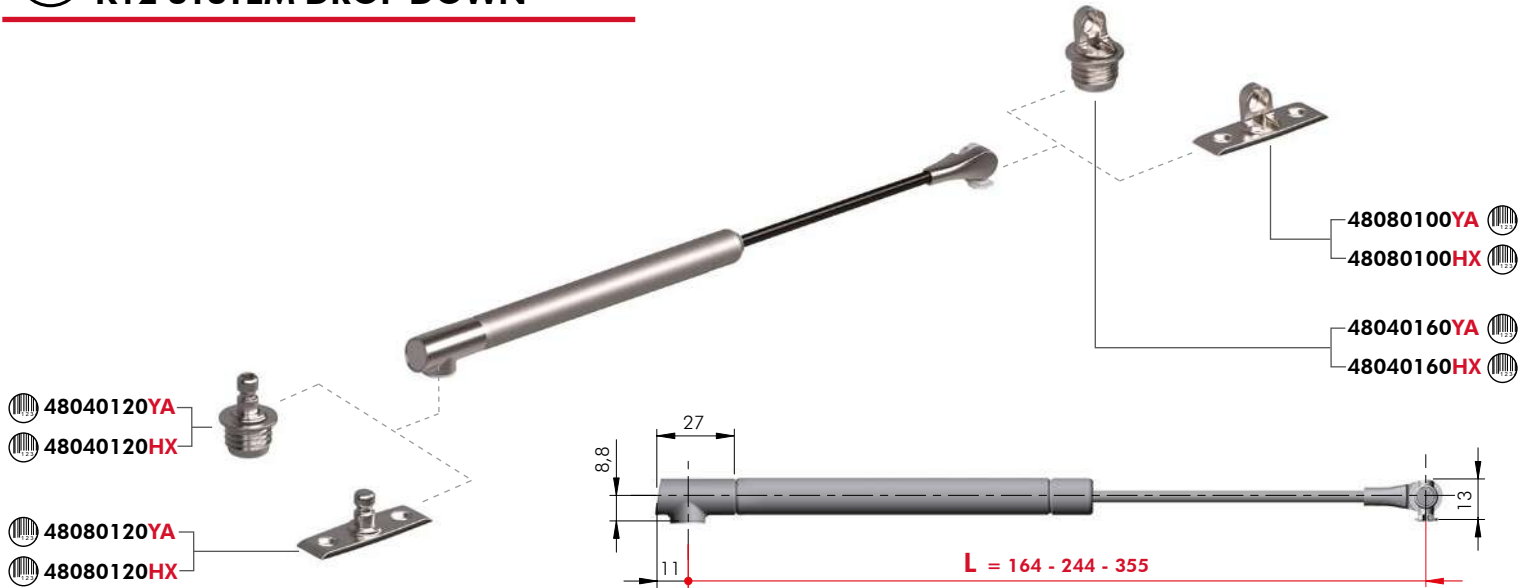

## K12 SYSTEM ADJ DROP DOWN

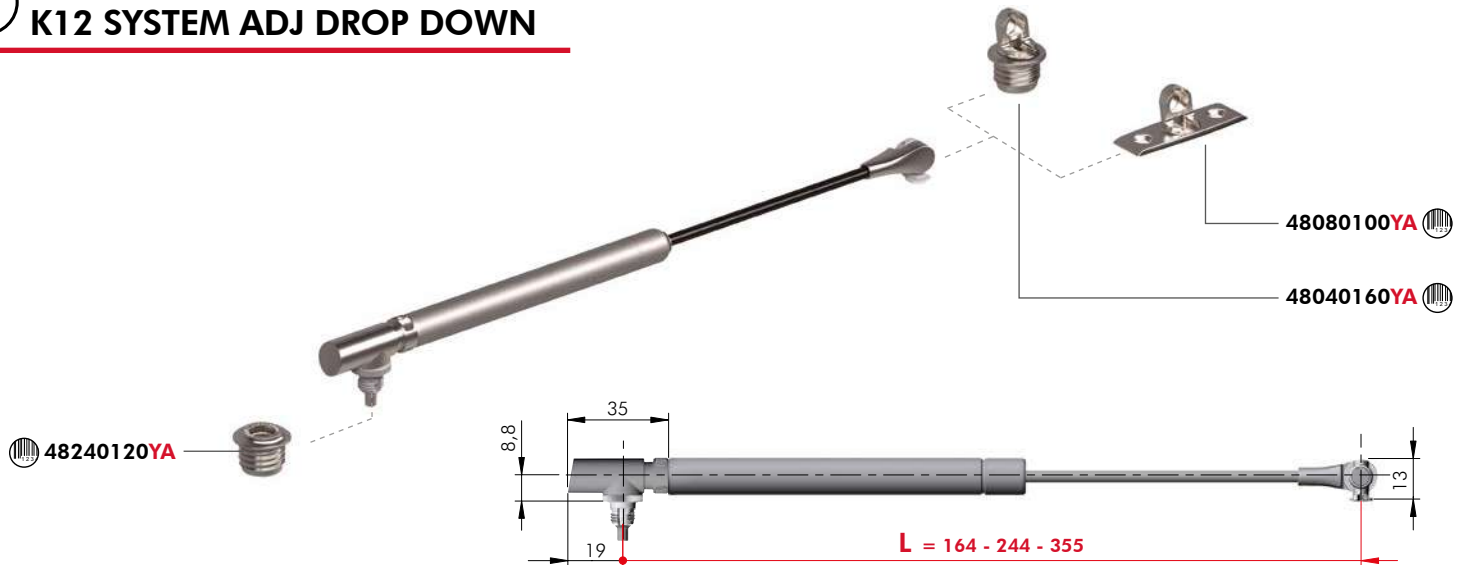

8

ZA EP ST

= 100 pcs. for L. 164 mm  
50 pcs. for L. 244 and 355 mm

L	K12 SYSTEM	K12 SYSTEM ADJ
164	48050200UZ	48250200UZ
244	48060200UZ	48260200UZ
355	48070200UZ	48270200UZ

+ Part.no + HX

+ Part.no + HX = K12 System with end parts in graphite finish are available on request.



## Number of stays chart - L 164 mm

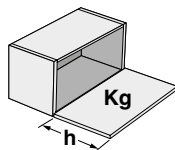

Rev. 02

h	Door weight (Kg)					
	1	2	3	4	5	6
200 - 224	1 x K12		2 x K12			
225 - 274	1 x K12		2 x K12			3 x K12
275 - 300	1 x K12		2 x K12		3 x K12	

## Number of stays chart - L 244 mm

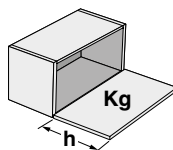

Rev. 02

h	Door weight (Kg)												
	1	2	3	4	5	6	7	8	9	10	11	12	13
290 - 324	1 x K12		2 x K12					3 x K12				4 x K12	
325 - 374	1 x K12		2 x K12				3 x K12				4 x K12		
375 - 424	1 x K12		2 x K12			3 x K12				4 x K12			
425 - 474	1 x K12		2 x K12		3 x K12			4 x K12				-	
475 - 500	1 x K12		2 x K12		3 x K12		4 x K12			-			

## Number of stays chart - L 355 mm

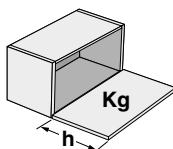

Rev. 02

h	Door weight (Kg)												
	1	2	3	4	5	6	7	8	9	10	11	12	13
390 - 424	-		1 x K12			2 x K12					3 x K12		
425 - 474	-		1 x K12			2 x K12				3 x K12			
475 - 524	-		1 x K12			2 x K12				3 x K12			
525 - 574	-		1 x K12		2 x K12			3 x K12				-	
575 - 600	1 x K12		2 x K12			3 x K12				4 x K12			

These are experimental results to be checked by the customer. **In accordance with the actual European regulation, we suggest to use at least two stays for each door.** Our technical department is at your disposal to test further cases out of this chart.





## DROP DOWN DRILLING PLANS WITH KIMANA HINGE

### L 164 mm

- Magnet K Lock  
visible or invisible
- K Push Tech 20 mm  
- With magnet  
- Visible or invisible

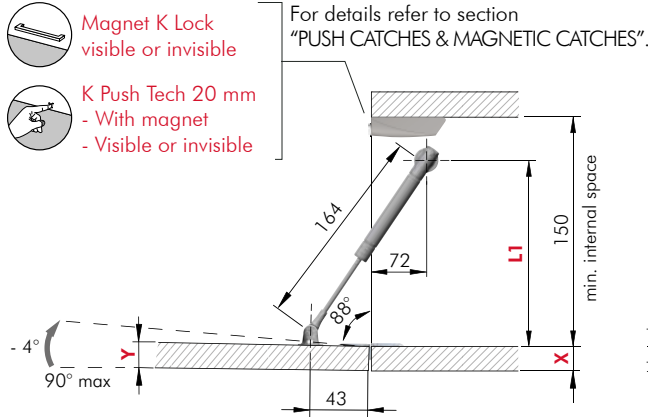

### SCREW FIXING BRACKETS:

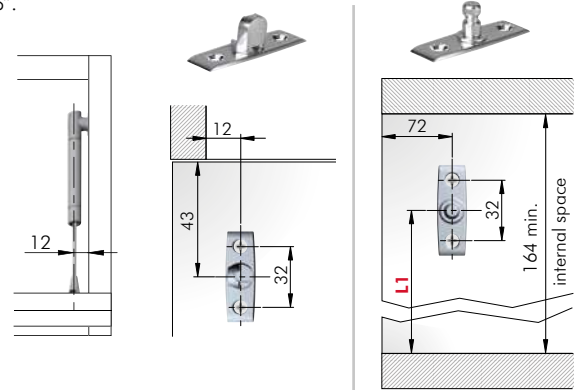

**Opening angle adjustment** is possible only with K12 SYSTEM ADJ version.

⚠ Overcrossing 90° door opening angle, it negatively effects the Kimana hinges.

Cabinet (X)		Door (Y)		L1
16 mm	4 mm	16 mm	2 mm	129
16 mm	4 mm	19 mm	-	131
18 mm	2 mm	18 mm	-	129
19 mm	-	16 mm	2 mm	125
19 mm	-	19 mm	-	127
20 mm	-	20 mm	-	127

adapter available in various thicknesses

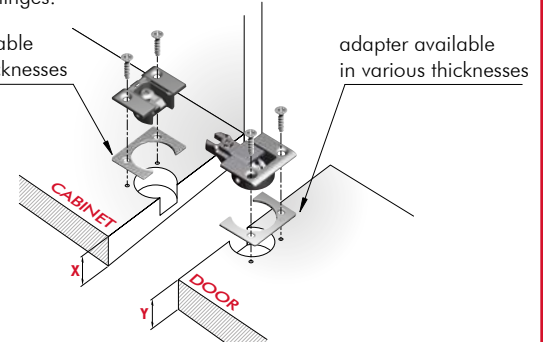

adapter available in various thicknesses

For Kimana and adapter details refer to section "HINGES".

### L 244 mm

- Magnet K Lock  
visible or invisible
- K Push Tech 20 mm  
- With magnet  
- Visible or invisible

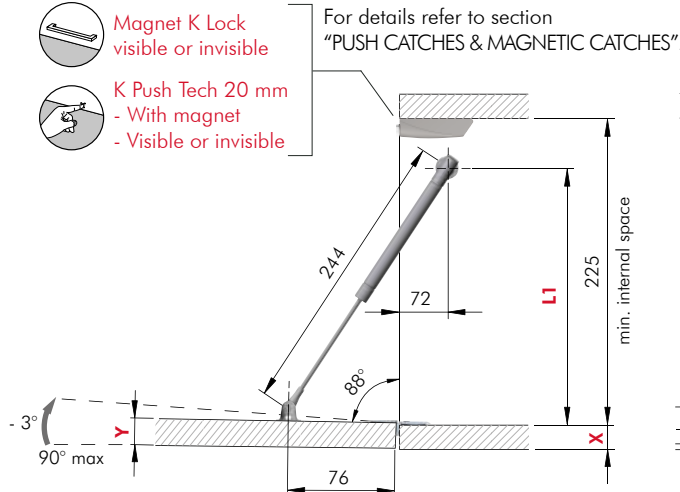

### SCREW FIXING BRACKETS:

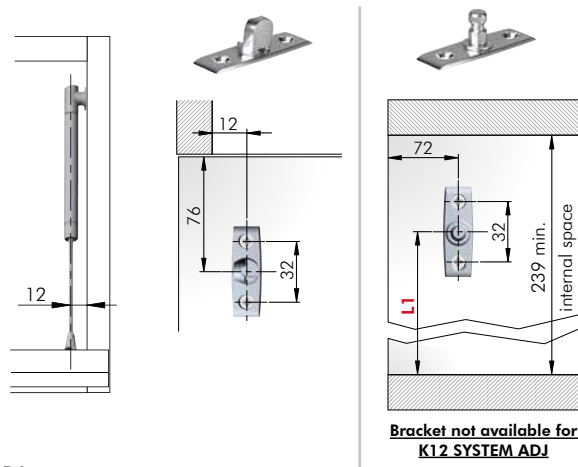

**Opening angle adjustment** is possible only with K12 SYSTEM ADJ version.

⚠ Overcrossing 90° door opening angle, it negatively effects the Kimana hinges.

Cabinet (X)		Door (Y)		L1
16 mm	4 mm	16 mm	2 mm	208
16 mm	4 mm	19 mm	-	210
18 mm	2 mm	18 mm	-	208
19 mm	-	16 mm	2 mm	204
19 mm	-	19 mm	-	206
20 mm	-	20 mm	-	206

adapter available in various thicknesses

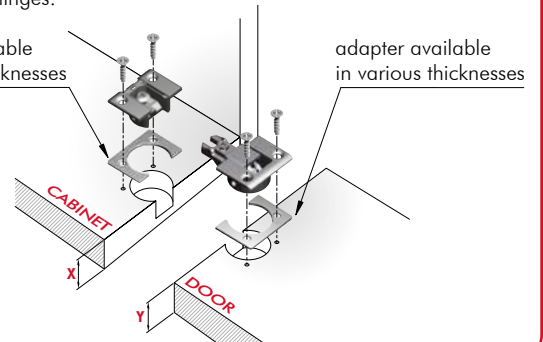



adapter available in various thicknesses

For Kimana and adapter details refer to section "HINGES".





L 355 mm

-  Magnet K Lock  
visible or invisible
-  K Push Tech 20 mm  
- With magnet  
- Visible or invisible

For details refer to section  
"PUSH CATCHES & MAGNETIC CATCHES".

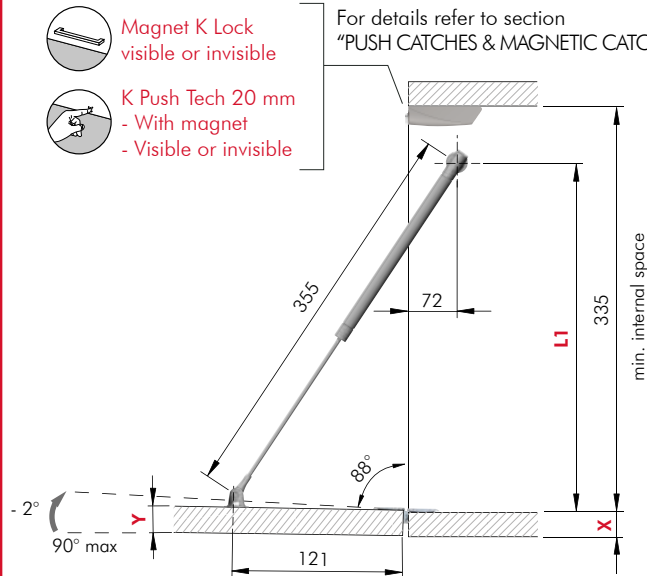

### SCREW FIXING BRACKETS:

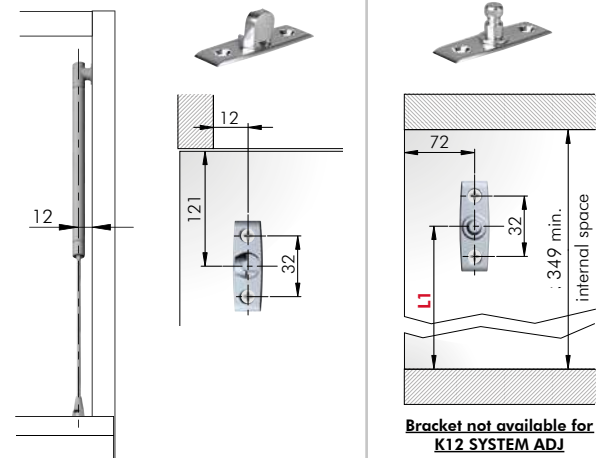

**Opening angle adjustment** is possible only with K12 SYSTEM ADJ version.

 Overcrossing 90° door opening angle, it negatively effects the Kimana hinges.

Cabinet (X)		Door (Y)		L1
16 mm	4 mm	16 mm	2 mm	314
16 mm	4 mm	19 mm	-	316
18 mm	2 mm	18 mm	-	314
19 mm	-	16 mm	2 mm	310
19 mm	-	19 mm	-	312
20 mm	-	20 mm	-	312

For Kimana and adapter details refer to section "HINGES".

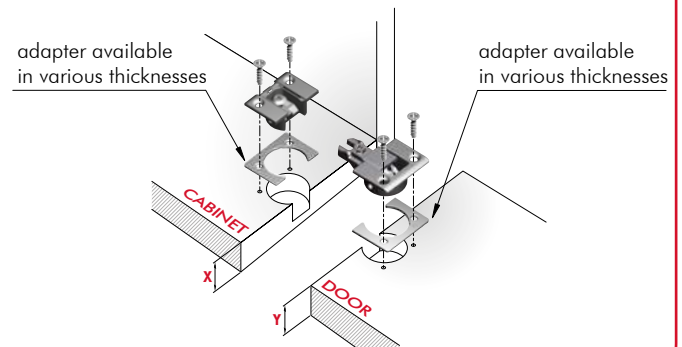

K12 SYSTEM CONFIGURATOR:



## DROP DOWN DRILLING PLANS WITH STANDARD HINGES OPENING WITH HANDLE

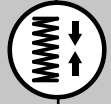
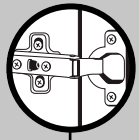
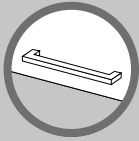

L 164 mm

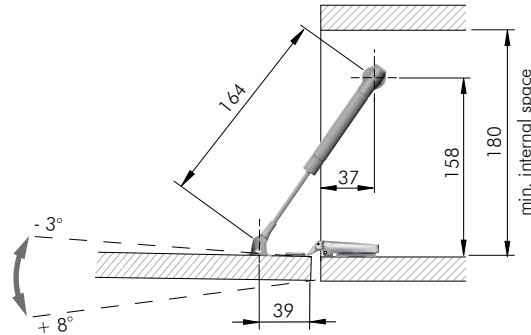

Opening angle adjustment is possible only with K12 SYSTEM ADJ version.

SCREW FIXING BRACKETS:

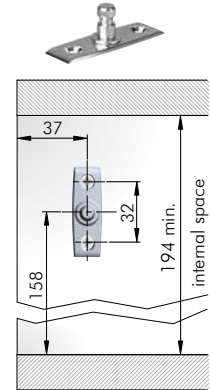
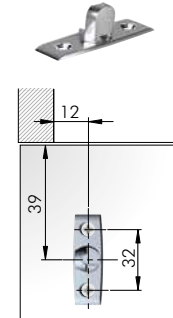

Bracket not available for K12 SYSTEM ADJ

L 244 mm

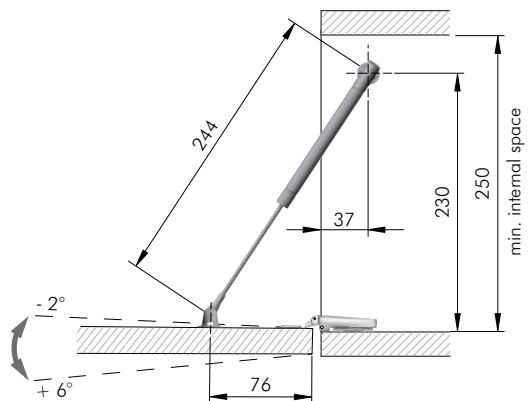

Opening angle adjustment is possible only with K12 SYSTEM ADJ version.

SCREW FIXING BRACKETS:

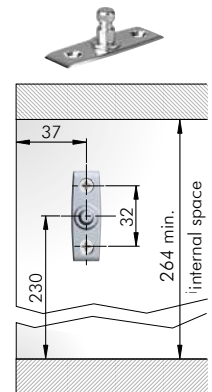
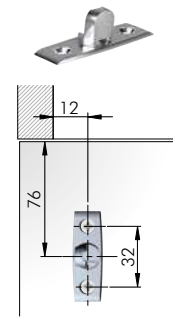

Bracket not available for K12 SYSTEM ADJ

L 355 mm

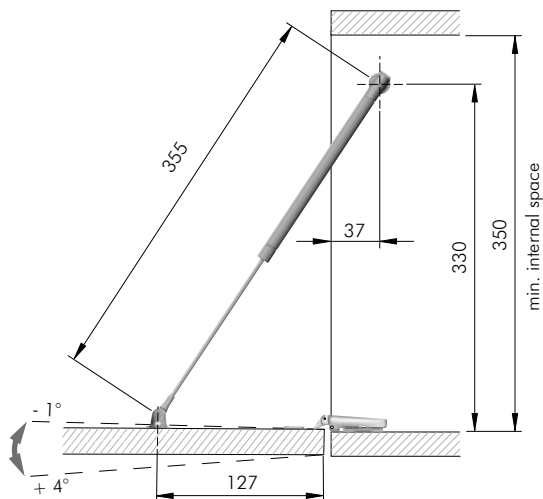

Opening angle adjustment is possible only with K12 SYSTEM ADJ version.

SCREW FIXING BRACKETS:

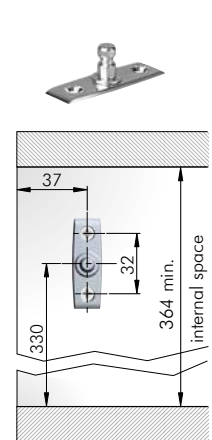
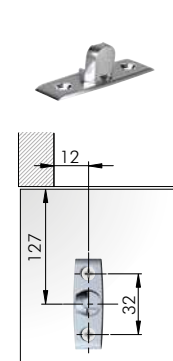

Bracket not available for K12 SYSTEM ADJ

The dimensions of the drilling plans refer to carcasses which use **standard sprung hinges** and mounting plates 0 mm. Please note that the opening angle varies with respect to the hinge brand and adjustment carried out.

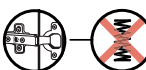

Please note that in case of use of **unsprung hinges**, **magnet K Lock** is required. For details refer to section "PUSH CATCHES & MAGNETIC CATCHES".



K12 SYSTEM CONFIGURATOR:



## DROP DOWN DRILLING PLANS WITH STANDARD HINGES PUSH TO OPEN

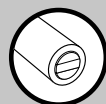
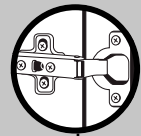

L 164 mm

K Push Tech 14 mm  
- With magnet  
- Visible or invisible

For details refer to section "PUSH CATCHES & MAGNETIC CATCHES".

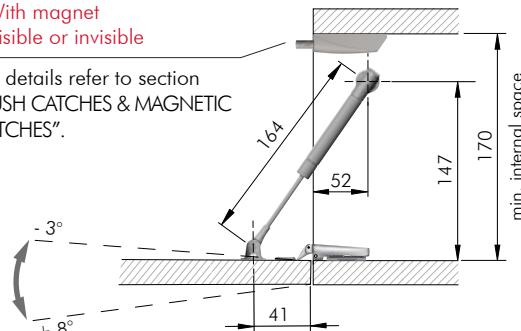

Opening angle adjustment is possible only with K12 SYSTEM ADJ version.

SCREW FIXING BRACKETS:

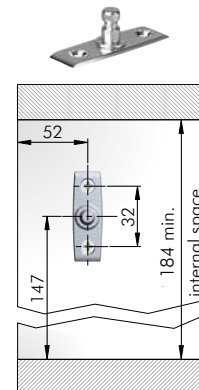
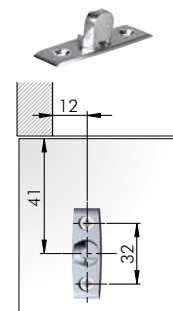

Bracket not available for K12 SYSTEM ADJ

L 244 mm

K Push Tech 14 mm  
- With magnet  
- Visible or invisible

For details refer to section "PUSH CATCHES & MAGNETIC CATCHES".

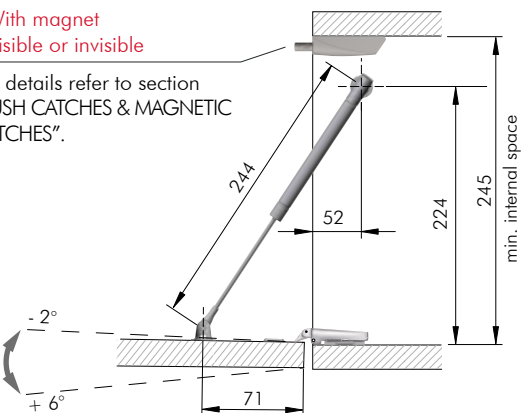

Opening angle adjustment is possible only with K12 SYSTEM ADJ version.

SCREW FIXING BRACKETS:

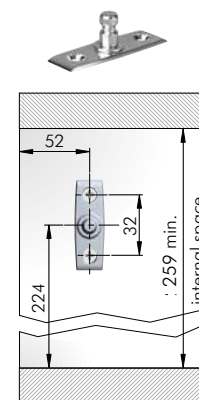
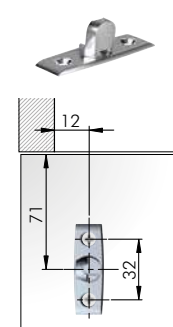

Bracket not available for K12 SYSTEM ADJ

L 355 mm

K Push Tech 14 mm  
- With magnet  
- Visible or invisible

For details refer to section "PUSH CATCHES & MAGNETIC CATCHES".

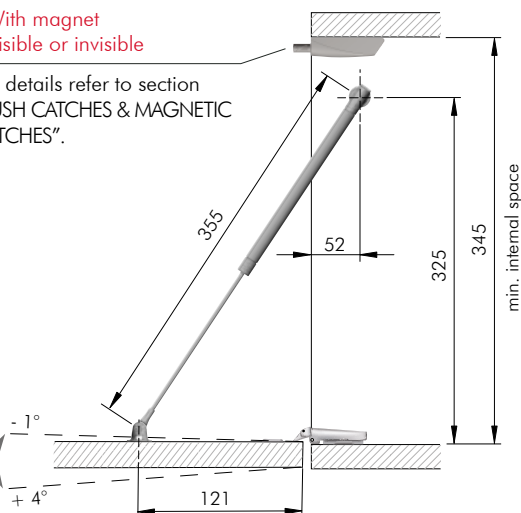

Opening angle adjustment is possible only with K12 SYSTEM ADJ version.

SCREW FIXING BRACKETS:

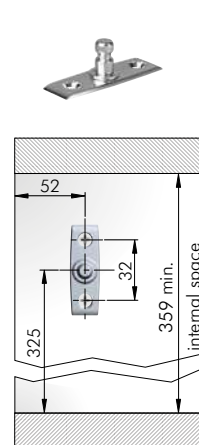
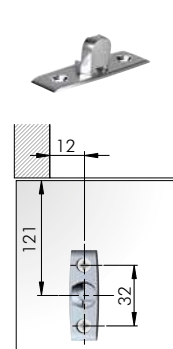

Bracket not available for K12 SYSTEM ADJ

The dimensions of the drilling plan refer to carcasses which use **standard unsprung hinges** and mounting plates 0 mm. Please note that the opening angle varies with respect to the hinge brand and adjustment carried out.

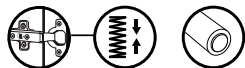

Please note that utilization with **standard sprung hinges** and **K Push Tech with buffer** is also possible. In such case, after the door is initially released by K Push Tech, a manual opening approx. 7cm is required (in order to win the spring resistance). Consequently, the door will automatically open to the fullest. For details refer to section "PUSH CATCHES & MAGNETIC CATCHES".



## DROP DOWN DRILLING PLANS WITH FLAP HINGE

K12 SYSTEM CONFIGURATOR:

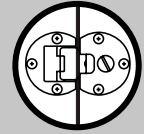
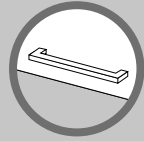

### L 164 mm

- Magnet K Lock visible or invisible
- K Push Tech 20 mm - With magnet - Visible or invisible

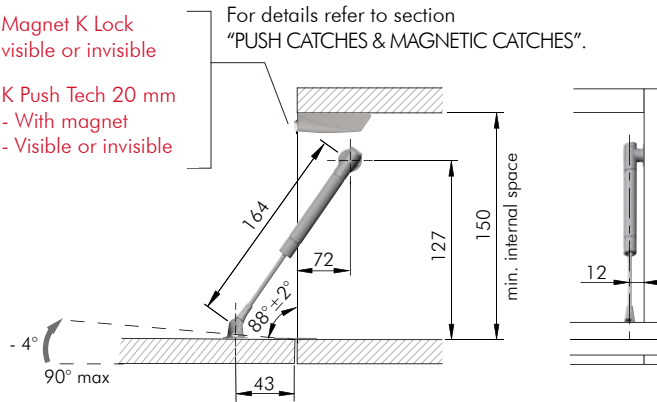

**Opening angle adjustment** is possible only with K12 SYSTEM ADJ version.  
 ⚠ Overcrossing 90° door opening angle, it negatively effects the flap hinges.

### SCREW FIXING BRACKETS:

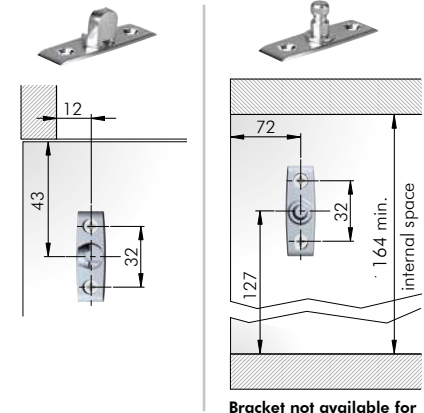

Bracket not available for K12 SYSTEM ADJ

### L 244 mm

- Magnet K Lock visible or invisible
- K Push Tech 20 mm - With magnet - Visible or invisible

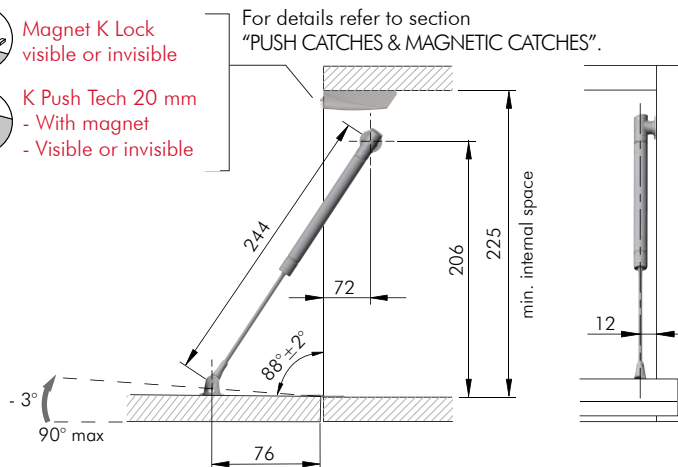

**Opening angle adjustment** is possible only with K12 SYSTEM ADJ version.  
 ⚠ Overcrossing 90° door opening angle, it negatively effects the flap hinges.

### SCREW FIXING BRACKETS:

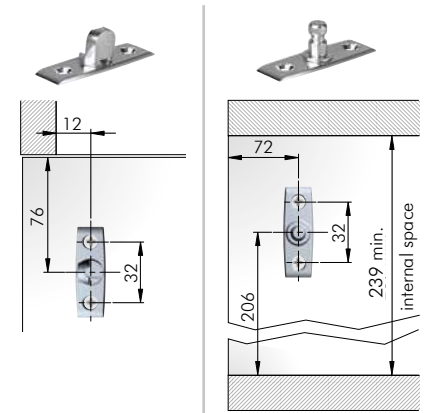

Bracket not available for K12 SYSTEM ADJ

### L 355 mm

- Magnet K Lock visible or invisible
- K Push Tech 20 mm - With magnet - Visible or invisible

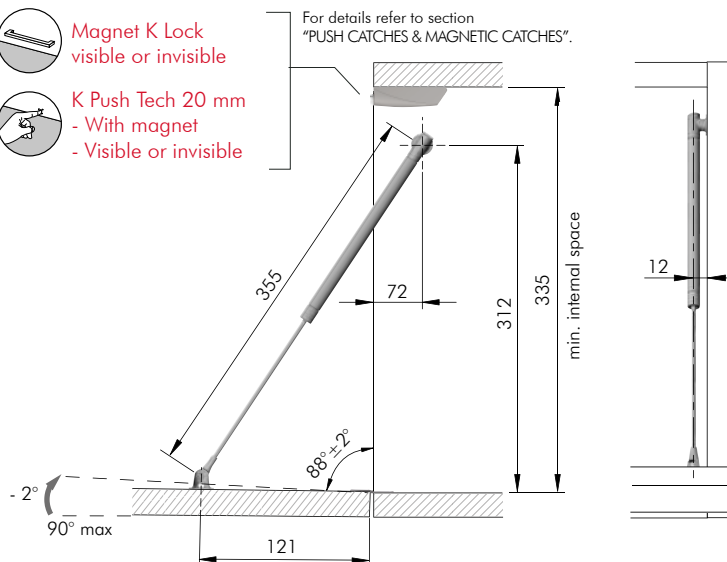

**Opening angle adjustment** is possible only with K12 SYSTEM ADJ version.  
 ⚠ Overcrossing 90° door opening angle, it negatively effects the flap hinges.

### SCREW FIXING BRACKETS:

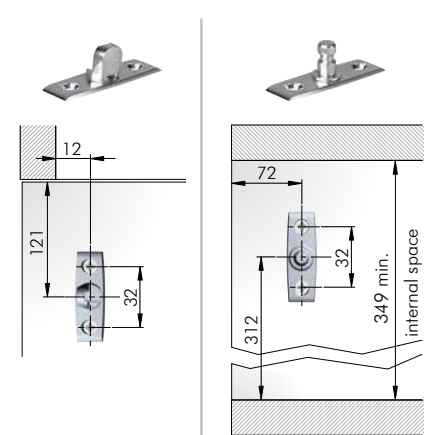

Bracket not available for K12 SYSTEM ADJ

The dimensions of the drilling plan refer to carcasses which use flap hinges.



## K12 SYSTEM & K12 SYSTEM ADJ BRACKETS

### SIDE BRACKET Ø15 - K12 SYSTEM

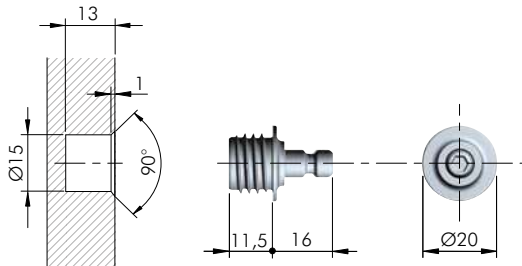

= Ø 15 mm

ZA



= 50 pcs.



48040120YA

48040120HX

### SIDE BRACKET Ø15 - K12 SYSTEM ADJ

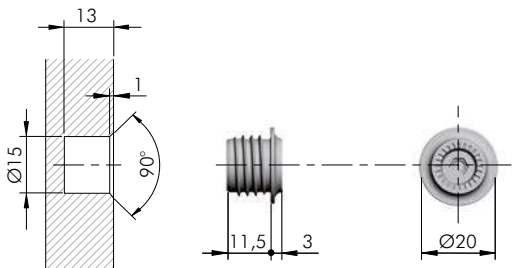

= Ø 15 mm

ZA



= 50 pcs.



48240120YA

### DOOR BRACKET Ø15

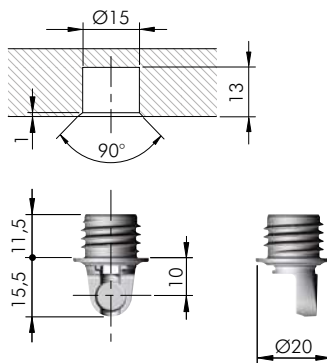

= Ø 15 mm

ZA



= 50 pcs.



48040160YA

48040160HX

## SCREW FIXING SIDE BRACKET (Not for K12 SYSTEM ADJ)

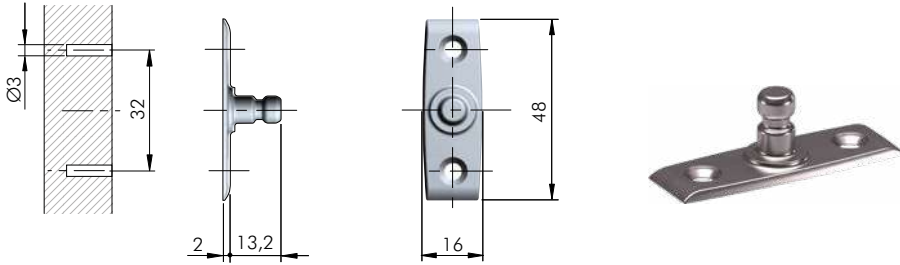

= Ø 3 mm	= 50 Stk.
ZA	
<b>48080120YA</b>	
<b>48080120HX</b>	

## SCREW FIXING DOOR BRACKET

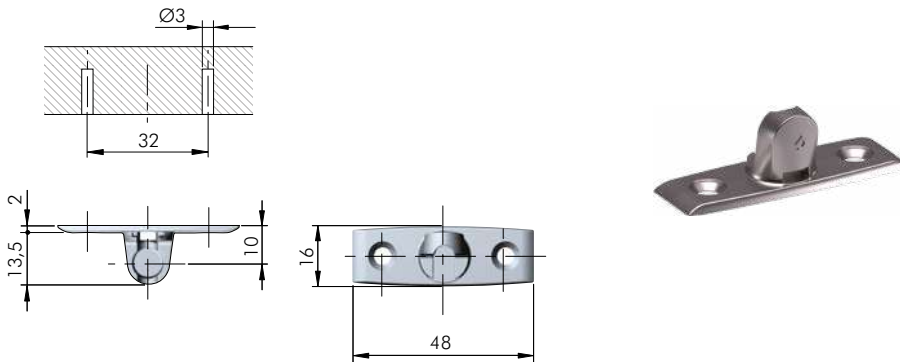

= Ø 3 mm	= 50 Stk.
ZA	
<b>48080100YA</b>	
<b>48080100HX</b>	

8

## SCREW FIXING BRACKETS ACCESSORY



= Ø 3 mm	+
= PZ2	
ST	= 10.000 pcs.
<b>60101390YA</b>	
<b>60101390HX</b>	



## K12 SYSTEM ADAPTERS FOR ALUMINIUM FRAME DOOR



INSTALLATION ON WIDER ALUMINIUM FRAME DOOR





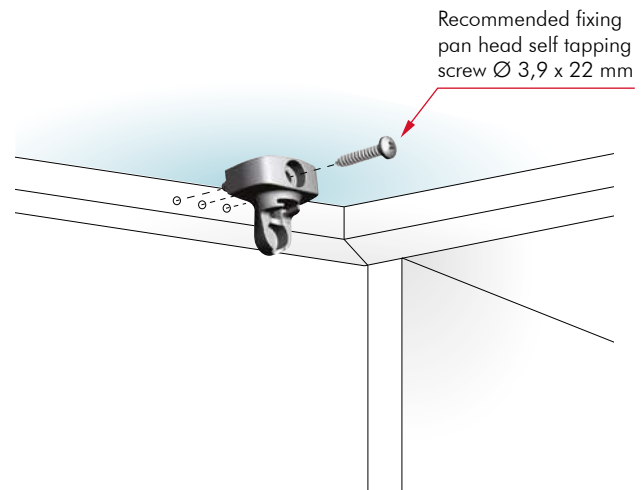
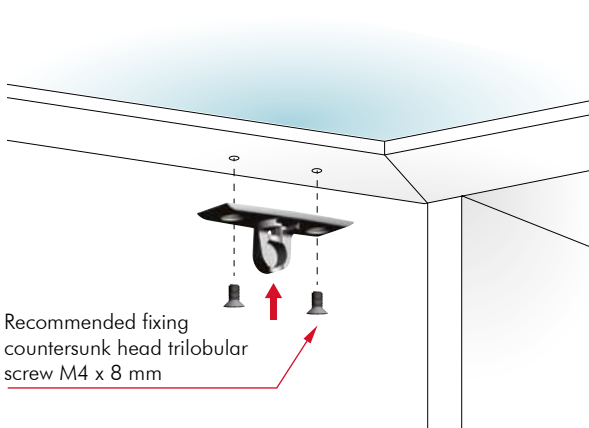

INSTALLATION ON NARROW ALUMINIUM FRAME DOOR

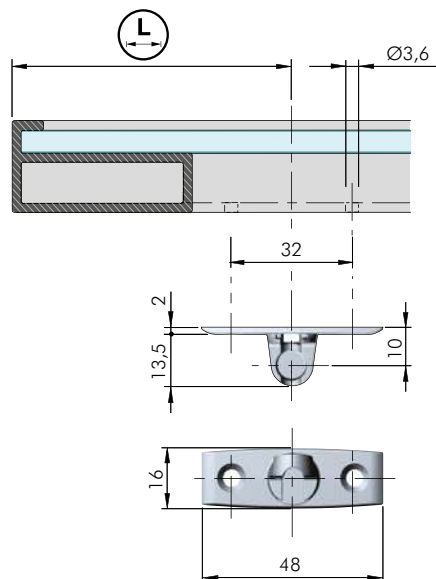
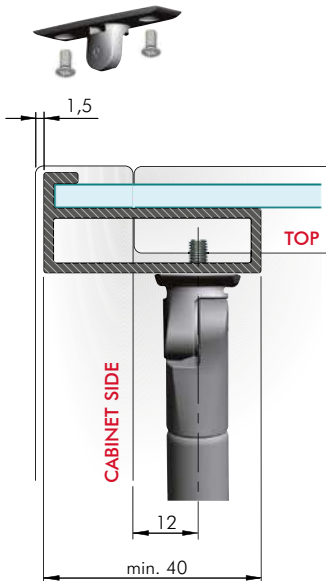

### WIDER ALUMINIUM FRAME DOOR (40 mm min.)



	= Ø 3,6 mm		= 50 pcs.
	ZA		
			
<b>48080100YA</b>			

# OPENING SYSTEMS FOR LIFT UP AND DROP DOWN DOORS

## NARROW ALUMINIUM FRAME DOOR (20 mm) WITH SIDE PANEL THICKNESS 16 mm

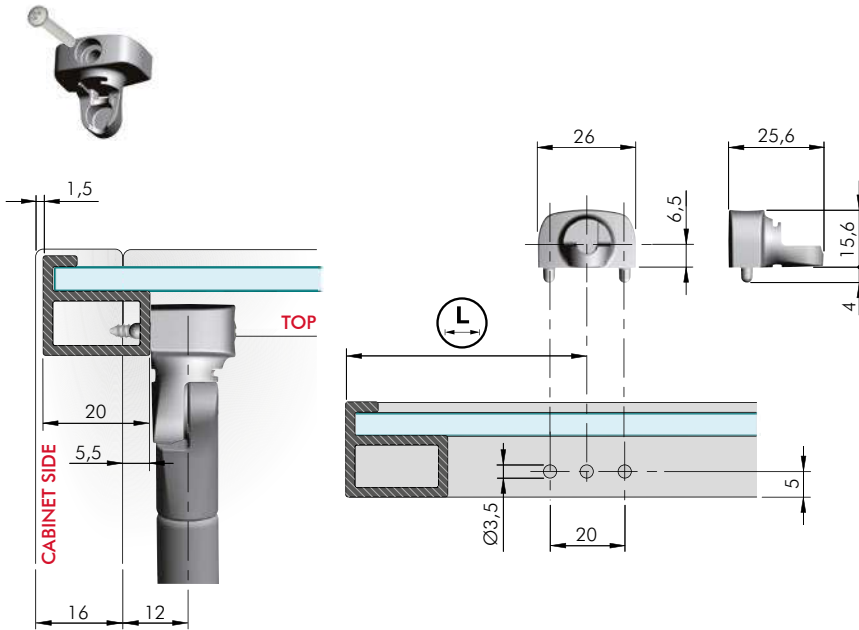

= Ø 3,5 mm  
 = on request  
 123   
**48080140YA**

## NARROW ALUMINIUM FRAME DOOR (20 mm) WITH SIDE PANEL THICKNESS 18 mm

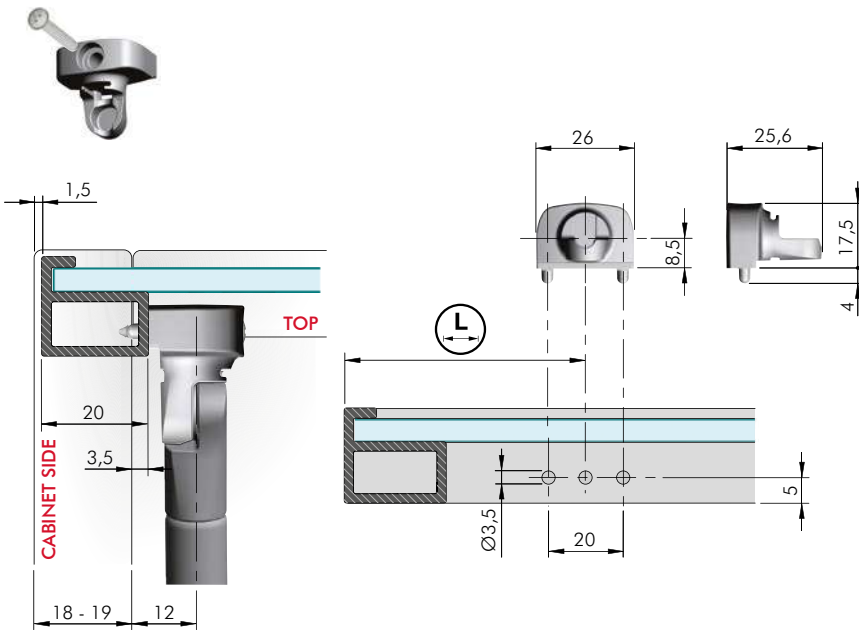

= Ø 3,5 mm  
 = on request  
 123   
**48080150YA**

8

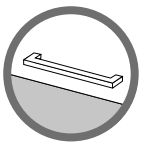

K12 System & K12 System ADJ	
164	39
244	76
355	127

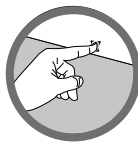

K12 System & K12 System ADJ	
164	41
244	71
355	121

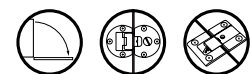

K12 System & K12 System ADJ	
164	43
244	76
355	121

For details refer to related sections.







[Back to table of contents](#)

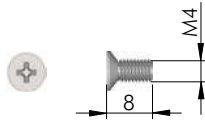







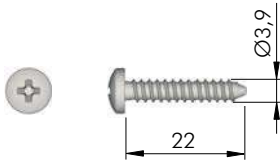

## ALUMINIUM ADAPTERS FIXING ACCESSORIES



			= PZ2
ST			= on request
			
<b>42906010YA</b>			



			= PZ2
ST			= on request
			
<b>60203390YA</b>			



## LINK

---



PATENTED



8



## INSTALLATION



The door bracket has to be placed with the narrow part of the drop-shaped slot facing the cabinet.

Recommended fixing countersunk head wood screws  $\varnothing 4 \times 18$  mm for door 18 mm min. thick.

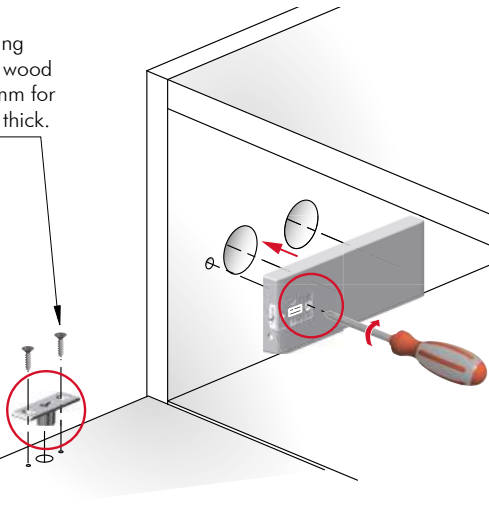

Pre-inserted screw  $\varnothing 3,5 \times 16$  mm - PZ2.

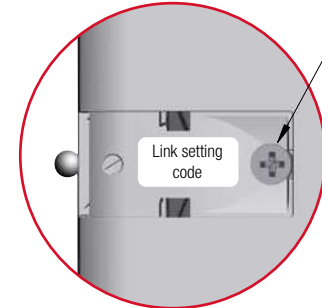

## UNHANDED MECHANISM

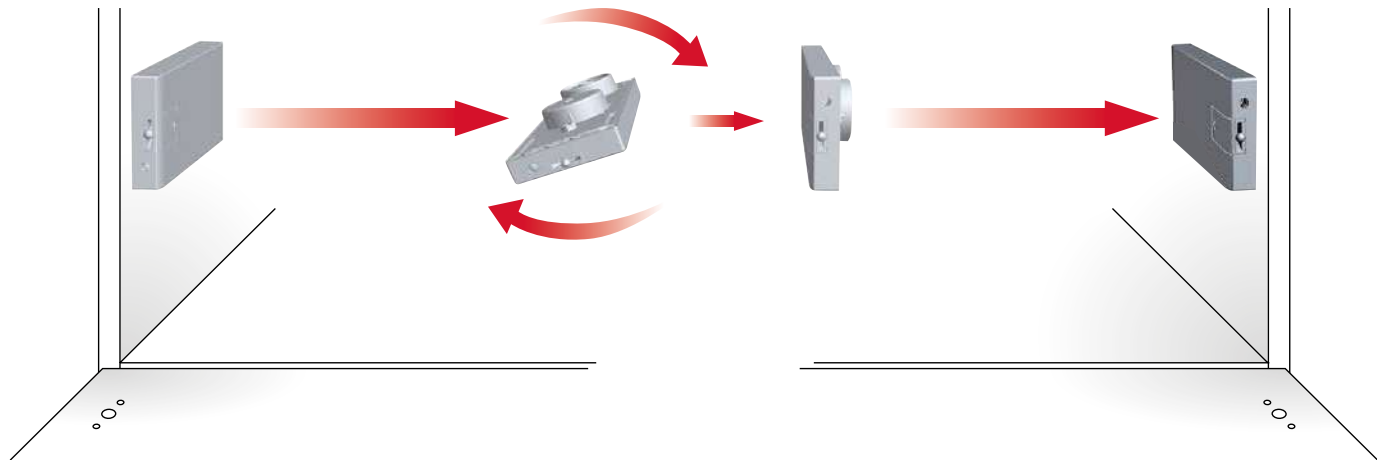

## COVER CAP INSERTION

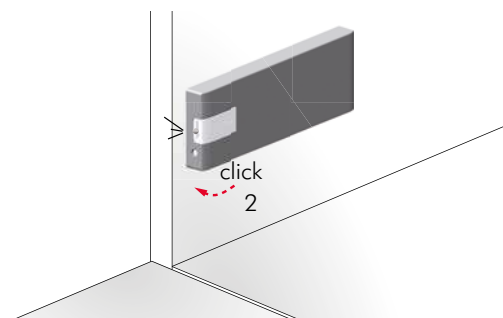
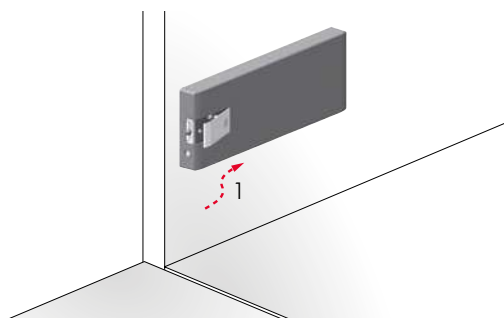

## METAL WIRE INSERTION ONTO THE DOOR BRACKET

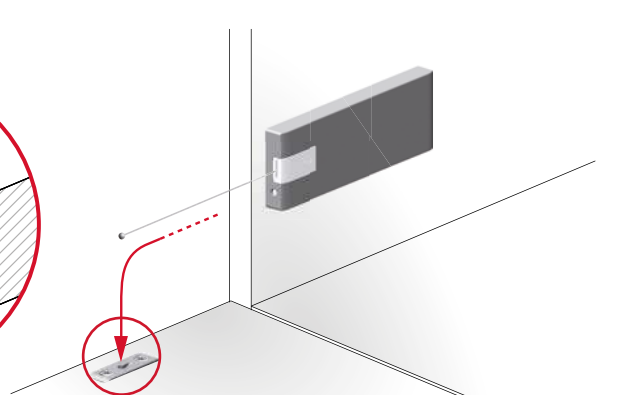
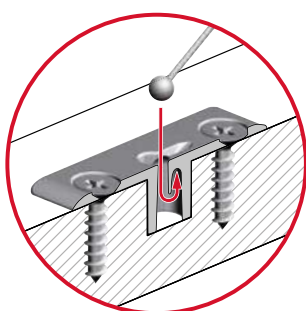

## PLASTIC WIRE LOCKING

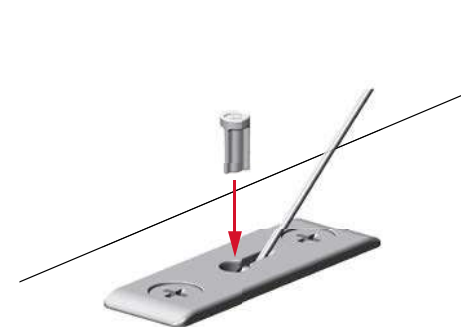

## ADJUSTMENT

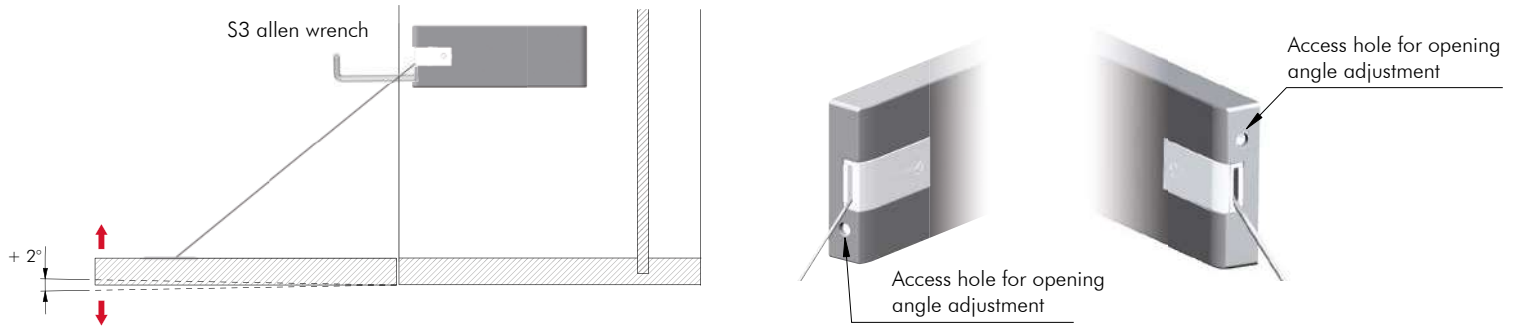

## SOFT OPENING

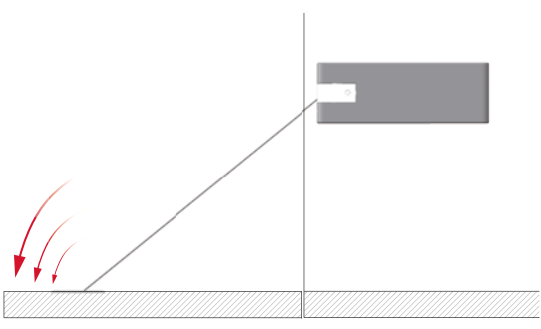

## SMOOTH CLOSING

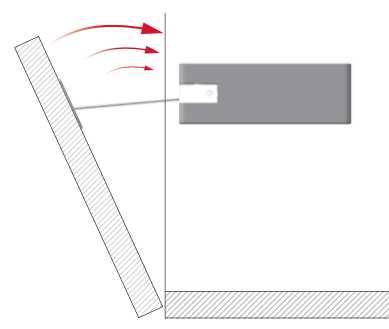

Soft opening and smooth closing are guaranteed only when opening and closing cycles are fully carried out.

## LINK REMOVAL

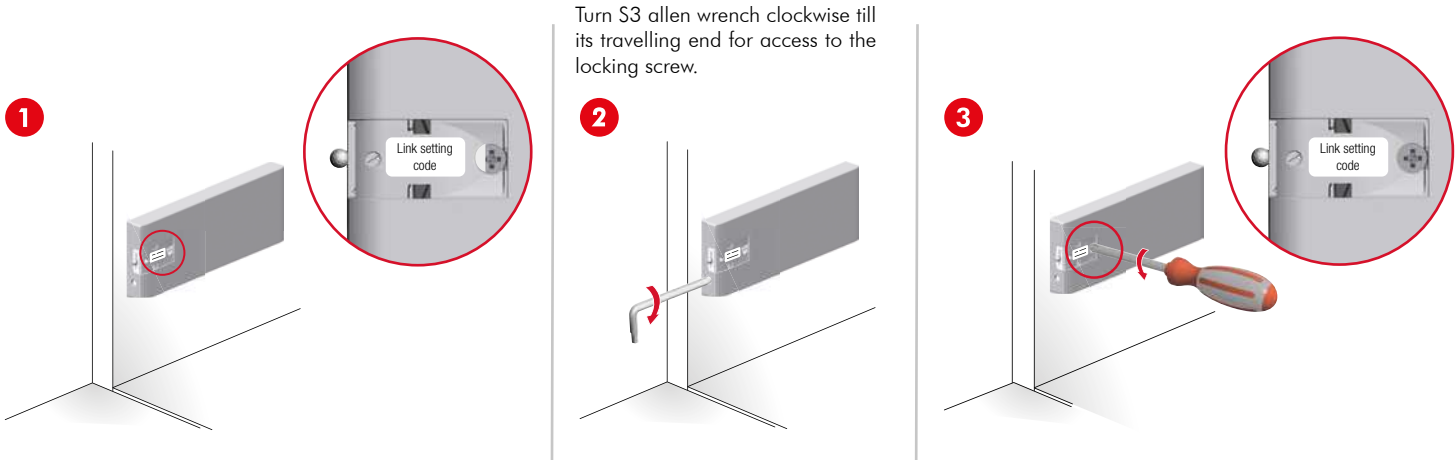

## LINK SETTINGS IDENTIFICATION

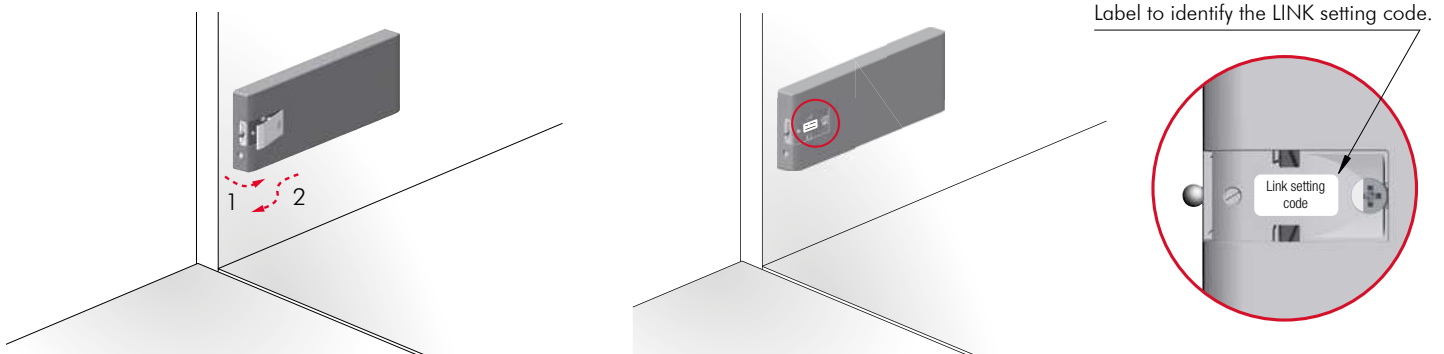

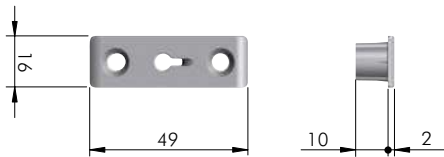

ZA	EP	ST	= 12 pcs.									
<b>47005020UZ</b>	AE	JL	FU	A262								
<b>47020020UZ</b>	AE	JL	FU	N262								
<b>47030020UZ</b>	AE	JL	FU	U262								
<b>47035020UZ</b>	AE	JL	FU	AL280								
<b>47038020UZ</b>	AE	JL	FU	AQ300								
<b>47040020UZ</b>	AE	JL	FU	AQ335								

NOTE: LINK is supplied in carton box including 1 piece, door bracket nickel-plated, countersunk fixing screws Ø 4 x 18 mm nickel-plated, cover cap and fitting guide.



# OPENING SYSTEMS FOR LIFT UP AND DROP DOWN DOORS

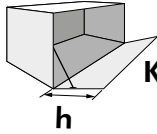

**Kg** = Door weight including the possible handle.

Rev. 02

Kg	Link	h															
		250	275	300	325	350	375	400	425	450	480						
1,75	x2	-	-	-	-	-	-	-	-	-	-	A262	A262	A262	A262	A262	A262
	x1	A262	N262	N262	N262	N262	N262	N262	N262	N262	N262	U262	U262	-	-	-	-
2,00	x2	-	-	-	-	-	-	A262	A262	A262	A262	A262	A262	A262	N262	A262	N262
	x1	N262	N262	N262	N262	N262	N262	U262	U262	-	-	-	-	-	-	AL280	AL280
2,25	x2	-	-	-	-	A262	A262	A262	A262	A262	A262	A262	N262	A262	N262	A262	N262
	x1	N262	N262	N262	N262	U262	U262	-	-	-	-	-	-	-	-	AL280	AL280
2,50	x2	-	-	A262	A262	A262	A262	A262	A262	A262	N262	A262	N262	A262	N262	A262	U262
	x1	N262	U262	U262	U262	-	-	-	-	-	-	-	-	-	AL280	AL280	AL280
2,75	x2	-	-	A262	A262	A262	A262	A262	N262	A262	N262	A262	U262	A262	U262	N262	U262
	x1	U262	U262	-	-	-	-	-	-	-	-	-	-	AL280	AL280	AL280	AQ300
3,00	x2	A262	A262	A262	A262	A262	N262	A262	N262	A262	N262	A262	U262	N262	U262	N262	U262
	x1	U262	-	-	-	-	-	AL280	AL280	AL280	AL280	AL280	AL280	AQ300	AQ300	AQ300	AQ300
3,25	x2	A262	A262	A262	N262	A262	N262	A262	N262	A262	U262	N262	U262	N262	U262	U262	U262
	x1	-	-	-	-	-	-	AL280	AL280	AL280	AL280	AQ300	AQ300	AQ300	AQ300	AQ300	AQ300
3,50	x2	A262	A262	A262	N262	A262	N262	A262	N262	A262	U262	N262	U262	U262	U262	N262	AL280
	x1	-	-	-	-	-	-	AL280	AL280	AQ300	AQ300	AQ300	AQ300	AQ300	AQ300	AQ300	AQ300
3,75	x2	A262	N262	A262	N262	A262	U262	A262	U262	N262	U262	N262	U262	U262	U262	N262	AL280
	x1	-	-	-	-	AL280	AL280	AQ300	AQ300	AQ300	AQ300	AQ300	AQ300	AQ300	AQ300	AQ335	AQ335
4,00	x2	A262	N262	A262	U262	A262	U262	N262	U262	N262	U262	N262	U262	U262	AL280	U262	AL280
	x1	-	-	-	-	AL280	AL280	AL280	AL280	AQ300	AQ300	AQ300	AQ300	AQ300	AQ300	AQ335	AQ335
4,25	x2	A262	N262	A262	U262	N262	U262	N262	U262	U262	U262	N262	AL280	U262	AL280	U262	AL280
	x1	-	-	AL280	AL280	AQ300	AQ300	AQ300	AQ300	AQ300	AQ300	AQ300	AQ300	AQ300	AQ300	AQ335	AQ335
4,50	x2	A262	U262	A262	U262	N262	U262	U262	U262	N262	AL280	U262	AL280	U262	AL280	AL280	AL280
	x1	AL280	AL280	AQ300	AQ300	AQ300	AQ300	AQ300	AQ300	AQ300	AQ300	AQ300	AQ300	AQ300	AQ300	-	-
4,75	x2	A262	U262	N262	U262	U262	U262	U262	AL280	N262	AL280	U262	AL280	U262	AL280	AL280	AL280
	x1	AL280	AQ300	AQ300	AQ300	AQ300	AQ300	AQ300	AQ300	AQ300	AQ300	AQ300	AQ300	AQ300	AQ300	AQ300	AQ300
5,00	x2	N262	U262	N262	U262	U262	U262	N262	AL280	U262	AL280	U262	AL280	AL280	AL280	AL280	AL280
	x1	AL280	AQ300	AQ300	AQ300	AQ300	AQ300	AQ300	AQ300	AQ300	AQ300	AQ300	AQ300	AQ300	AQ300	AQ300	AQ300
5,25	x2	N262	U262	U262	U262	U262	U262	N262	AL280	U262	AL280	U262	AL280	AL280	AL280	AL280	AL280
	x1	AL280	AQ300	AQ300	AQ300	AQ300	AQ300	AQ300	AQ300	AQ300	AQ300	AQ300	AQ300	AQ300	AQ300	AQ300	AL280
5,50	x2	N262	U262	U262	U262	N262	AL280	U262	AL280	U262	AL280	AL280	AL280	AL280	AL280	AL280	AQ300
	x1	AL280	AQ300	AQ300	AQ300	AQ300	AQ300	AQ300	AQ300	AQ300	AQ300	AQ300	AQ300	AQ300	AQ300	AQ300	AQ300
5,75	x2	U262	U262	U262	U262	N262	AL280	U262	AL280	U262	AL280	AL280	AL280	AL280	AQ300	AL280	AQ300
	x1	AQ300	AQ300	AQ300	AQ300	AQ300	AQ300	AQ300	AQ300	AQ300	AQ300	AQ300	AQ300	AQ300	AQ300	AQ300	AQ300
6,00	x2	U262	U262	N262	AL280	U262	AL280	U262	AL280	AL280	AL280	AL280	AL280	AL280	AQ300	AL280	AQ300
	x1	AQ300	AQ300	AQ300	AQ300	AQ300	AQ300	AQ300	AQ300	AQ300	AQ300	AQ300	AQ300	AQ300	AQ300	AQ300	AQ300
6,25	x2	U262	U262	N262	AL280	U262	AL280	U262	AL280	AL280	AL280	AL280	AL280	AL280	AQ300	AQ300	AQ300
	x1	AQ300	AQ300	AQ300	AQ300	AQ300	AQ300	AQ300	AQ300	AQ300	AQ300	AQ300	AQ300	AQ300	AQ300	AQ300	AQ300
6,50	x2	N262	AL280	U262	AL280	U262	AL280	AL280	AL280	AL280	AL280	AL280	AL280	AQ300	AQ300	AQ300	AQ300
	x1	AQ300	AQ300	AQ300	AQ300	-	-	-	-	-	-	-	-	-	-	-	-
6,75	x2	N262	AL280	U262	AL280	U262	AL280	AL280	AL280	AL280	AL280	AL280	AL280	AQ300	AQ300	AQ300	AQ300
	x1	AQ300	AQ300	AQ300	AQ300	-	-	-	-	-	-	-	-	-	-	-	-
7,00	x2	U262	AL280	U262	AL280	AL280	AL280	AL280	AL280	AL280	AQ300	AL280	AQ300	AQ300	AQ300	AQ300	AQ300
	x1	AQ300	AQ300	AQ300	AQ300	-	-	-	-	-	-	-	-	-	-	-	-
7,50	x2	U262	AL280	AL280	AL280	AL280	AL280	AL280	AL280	AL280	AQ300	AQ300	AQ300	AQ300	AQ300	AQ300	AQ300
	x1	AQ300	AQ300	AQ300	AQ300	-	-	-	-	-	-	-	-	-	-	-	-
8,00	x2	U262	AL280	AL280	AL280	AL280	AL280	AL280	AQ300	AQ300	AQ300	AQ300	AQ300	AQ300	AQ300	AQ300	AQ300
	x1	AL280	AL280	AL280	AL280	AL280	AQ300	AQ300	AQ300	AQ300	AQ300	AQ300	AQ300	AQ300	AQ300	AQ300	AQ300
8,25	x2	AL280	AL280	AL280	AL280	AL280	AQ300	AL280	AQ300	AQ300	AQ300	AQ300	AQ300	AQ300	AQ300	AQ300	AQ300
	x1	AL280	AL280	AL280	AL280	AL280	AQ300	AQ300	AQ300	AQ300	AQ300	AQ300	AQ300	AQ300	AQ300	AQ300	AQ300
8,50	x2	AL280	AL280	AL280	AL280	AL280	AQ300	AQ300	AQ300	AQ300	AQ300	AQ300	AQ300	AQ300	AQ300	AQ300	AQ300
	x1	AL280	AL280	AL280	AL280	AL280	AQ300	AQ300	AQ300	AQ300	AQ300	AQ300	AQ300	AQ300	AQ300	AQ300	AQ300
8,75	x2	AL280	AL280	AL280	AL280	AL280	AQ300	AQ300	AQ300	AQ300	AQ300	AQ300	AQ300	AQ300	AQ300	AQ300	AQ300
	x1	AL280	AL280	AL280	AL280	AL280	AQ300	AQ300	AQ300	AQ300	AQ300	AQ300	AQ300	AQ300	AQ300	AQ300	AQ300
9,00	x2	AL280	AL280	AL280	AL280	AL280	AQ300	AQ300	AQ300	AQ300	AQ300	AQ300	AQ300	AQ300	AQ300	AQ300	AQ300
	x1	AL280	AL280	AL280	AL280	AL280	AQ300	AQ300	AQ300	AQ300	AQ300	AQ300	AQ300	AQ300	AQ300	AQ300	AQ300

CODE SETTINGS: A262, N262, U262, AL280 \*

CODE SETTINGS: AL280, AQ300, AQ335

\* For alternative applications with 1 mechanism LINK only, the remaining settings AQ300 – AQ335 might be required.

These are experimental results to be checked by the customer.

In accordance with the actual European regulation, we suggest to use two LINK mechanisms for each door. In case the door weight/dimensions are bigger than those reported on the chart, three or more LINK mechanisms might be used. Our technical department is at your disposal to test further cases out of this chart.



## LINK WITH KIMANA HINGE

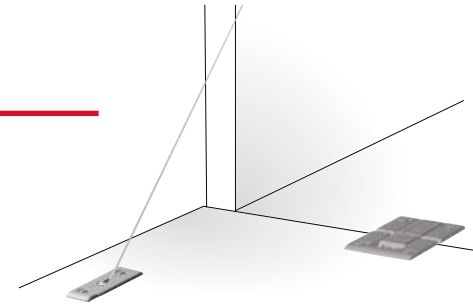
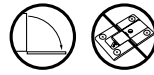

DOOR PANEL DRILLING PLAN

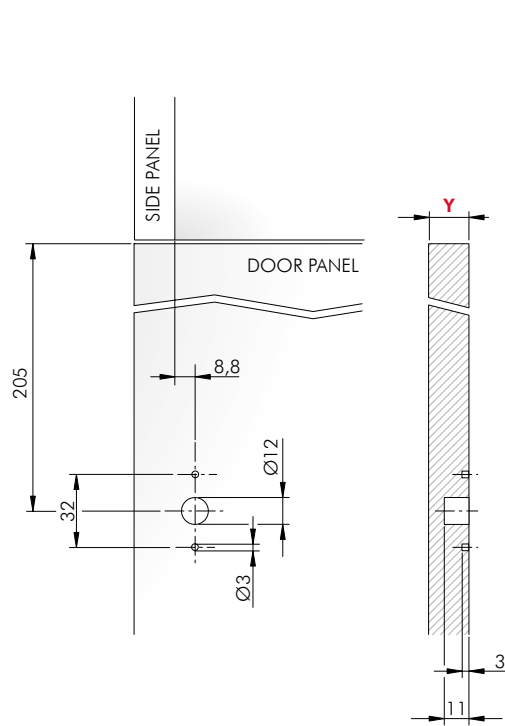

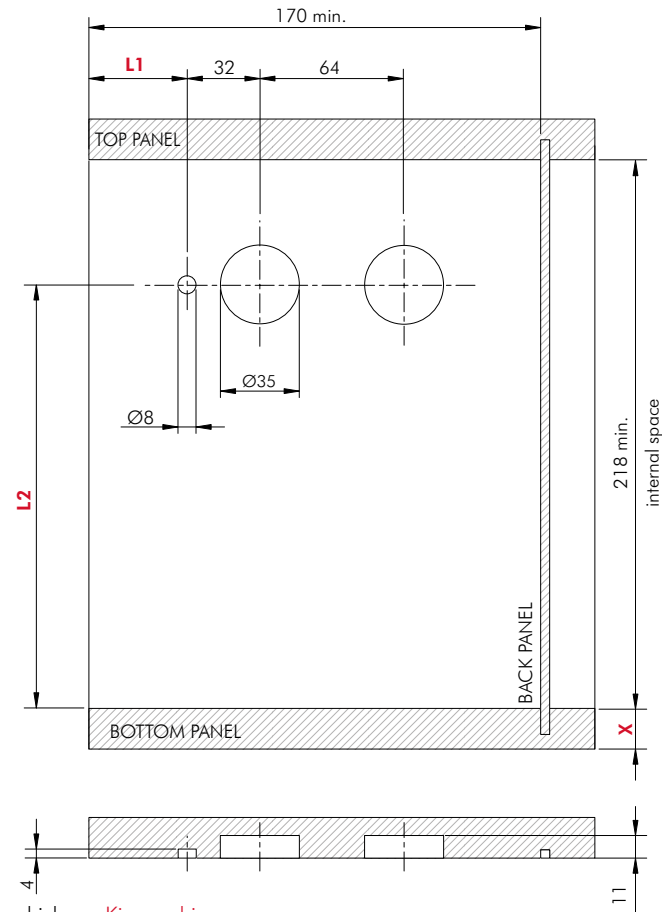

SIDE PANEL DRILLING PLAN

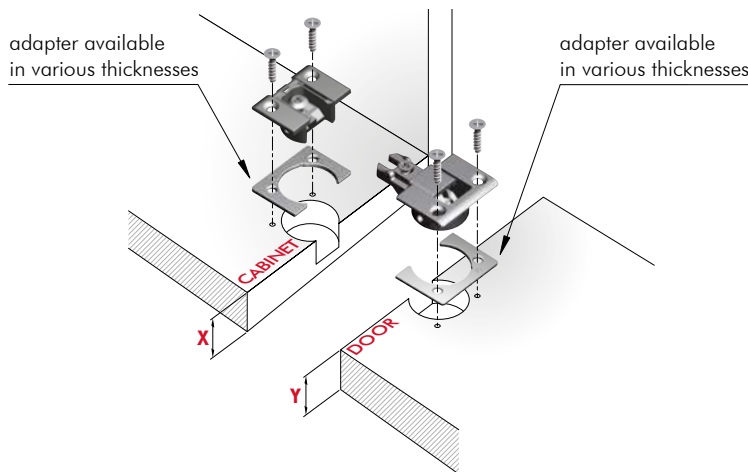

The dimensions of the above drilling plan refer to carcasses which use **Kimana hinges**.



X + 	Y + 	L1	L2
16 + 4	16 + 2	43	190
16 + 4	19	44	190
18 + 2	18	44	189
18 + 2	19	44	189
19	16 + 2	42	187
19	19	43	187
20	20	43	187

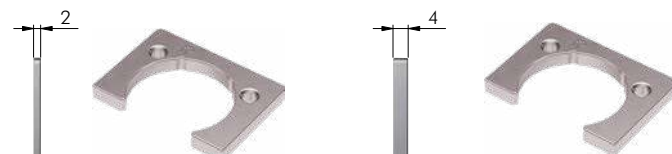

For Kimana and adapter details refer to section "HINGES".

## LINK WITH FLAP HINGES

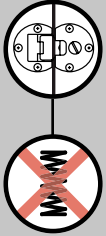
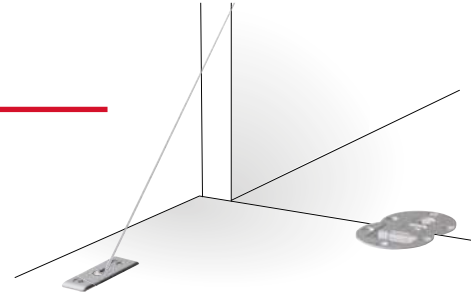
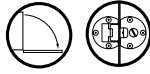

DOOR PANEL DRILLING PLAN

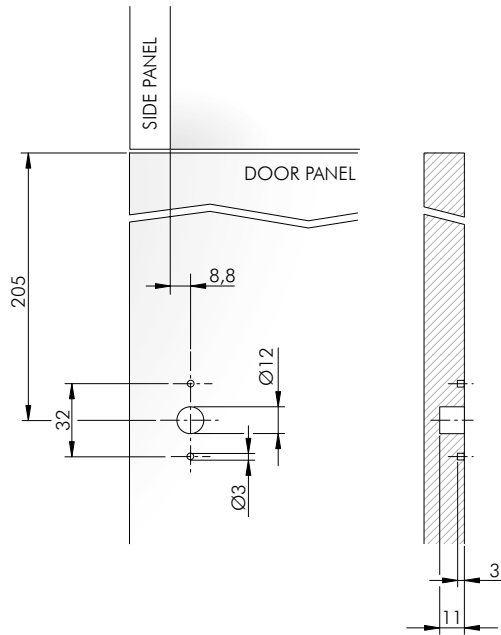

SIDE PANEL DRILLING PLAN

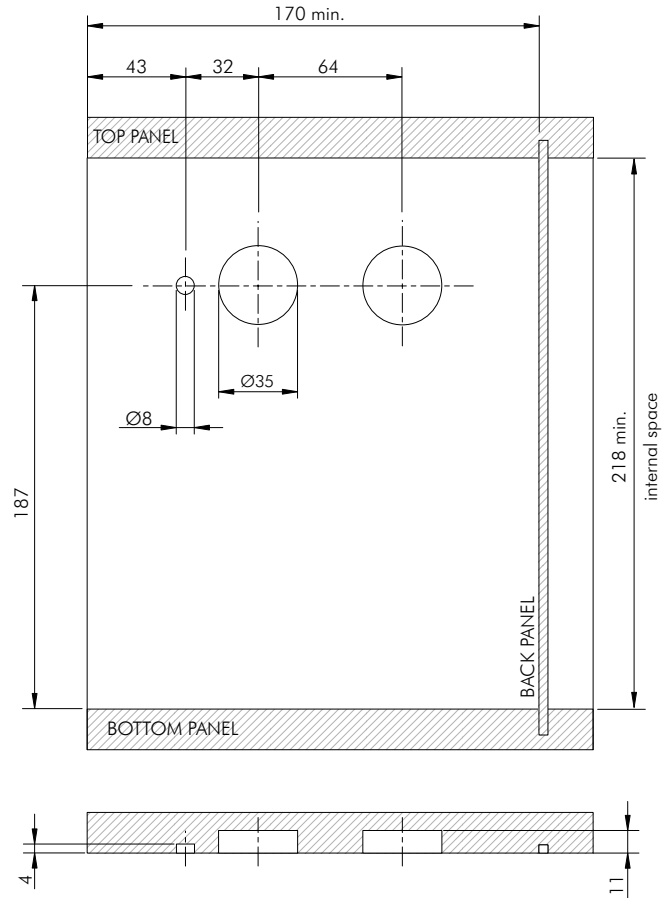

The dimensions of the drilling plan refer to carcasses which use flap hinges.

8

## LINK WITH STANDARD UNSPRUNG HINGES

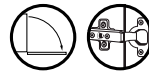

In case the hinges to be installed are not KIMANA hinges, please contact our technical department to receive the correct drilling plan. It is necessary to indicate all the values requested in the following diagram:

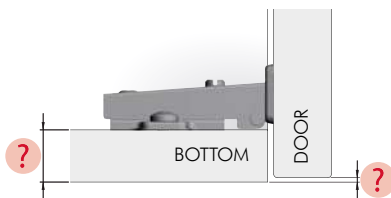

CLOSING CONDITION

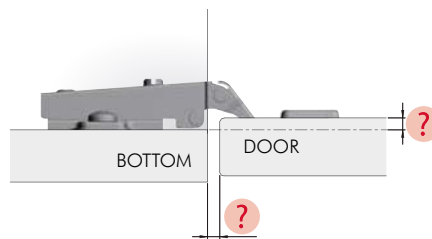

OPENING CONDITION





## KIARO



PAT. PENDING

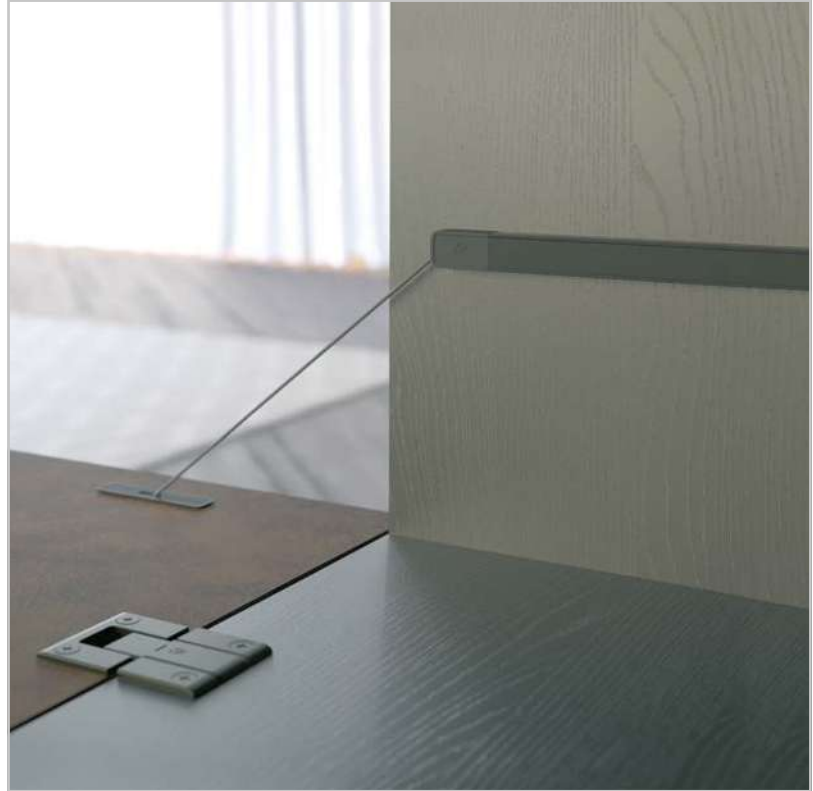

### ADJUSTMENT OF STRENGTH SETTINGS

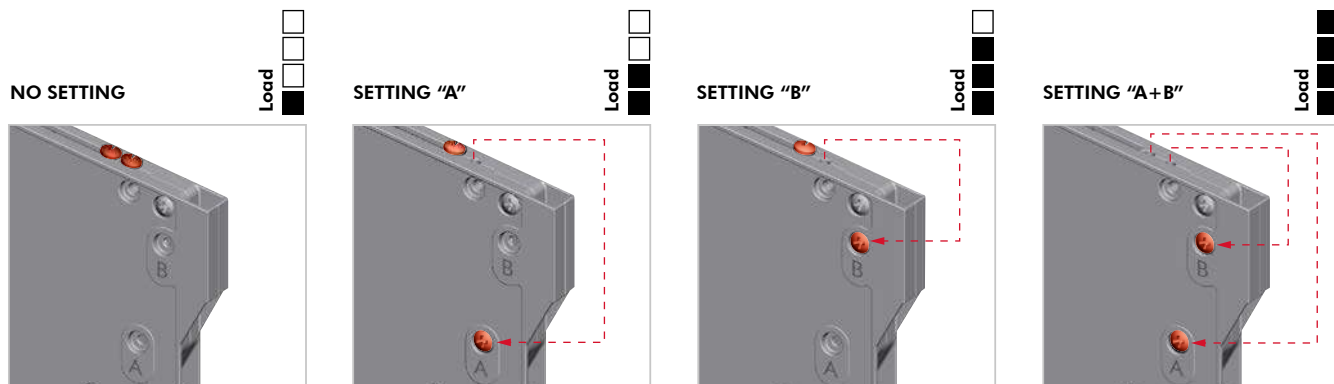
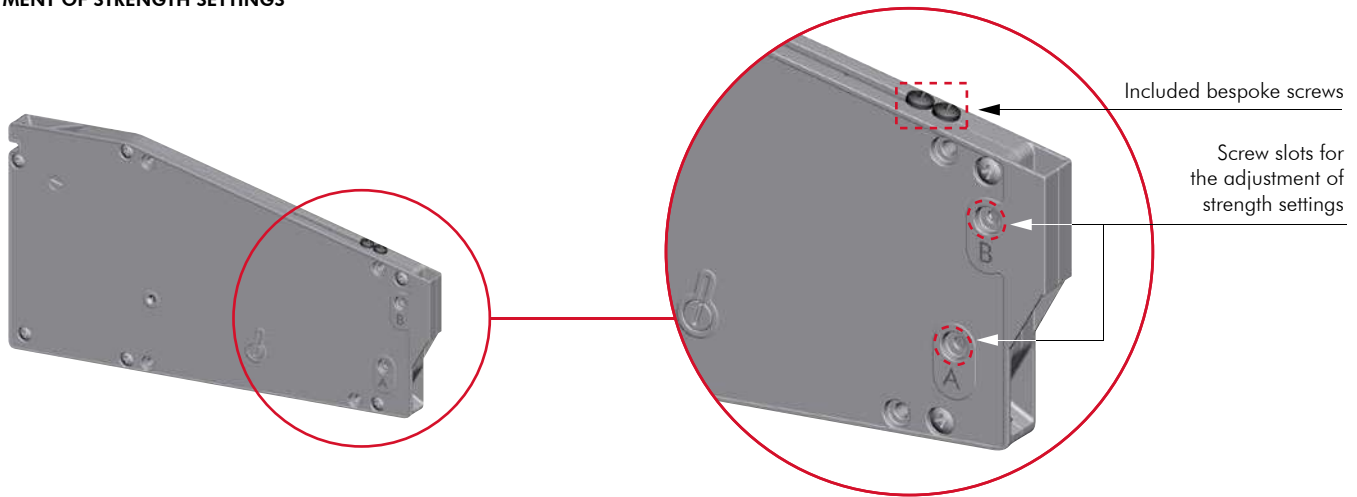



## SOFT OPENING

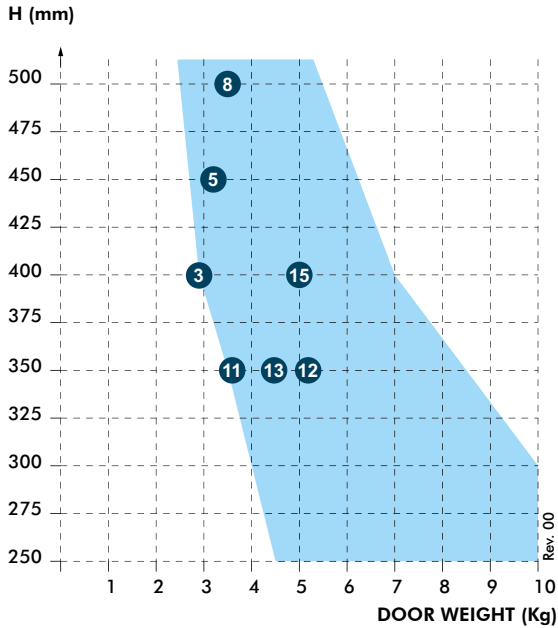

1 mechanism  
**KIARO**

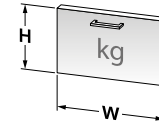
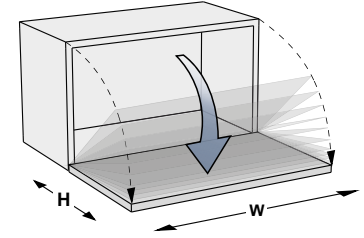

Door weight including the possible handle.

		H mm	W mm	Weight theoretical
1	Chipboard door thk 18mm	350	1200	4,9 kg
2	Chipboard door thk 18mm	350	1500	6,5 kg
3	Chipboard door thk 18mm	400	600	2,9 kg
4	Chipboard door thk 18mm	400	1200	5,8 kg
5	Chipboard door thk 18mm	450	600	3,2 kg
6	Chipboard door thk 18mm	450	1200	6,3 kg
7	Chipboard door thk 18mm	450	1500	7,9 kg
8	Chipboard door thk 18mm	500	600	3,5 kg
9	Chipboard door thk 18mm	500	1200	7,0 kg
10	Chipboard door thk 18mm	500	1500	9,1 kg
11	Chipboard door thk 25mm	350	600	3,5 kg
12	Chipboard door thk 25mm	350	900	5,2 kg
13	MDF door thk 18mm	350	900	4,4 kg
14	MDF door thk 18mm	350	1200	6,0 kg
15	MDF door thk 18mm	400	900	5,0 kg
16	MDF door thk 18mm	400	1200	6,8 kg
17	MDF door thk 18mm	500	1200	8,5 kg
18	Chipb. 18mm + glass 4mm	350	900	7,2 kg
19	Chipb. 18mm + glass 4mm	400	900	7,9 kg
20	Chipb. 18mm + glass 4mm	400	1200	10,4 kg

Weight considering: Chipboard 650 Kg/m<sup>3</sup> and MDF 780 Kg/m<sup>3</sup>.

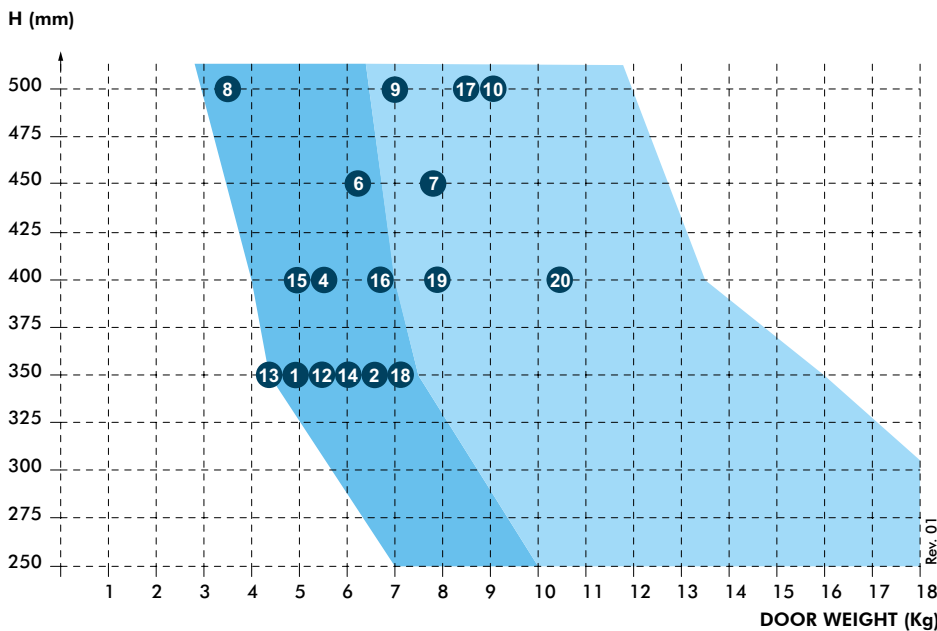

1 mechanism + KIARO S      2 mechanisms  
**KIARO**

These are experimental results to be checked by the customer.

In accordance with the actual European regulation, we suggest where possible to use two KIARO mechanisms for each door. Our technical department is at your disposal to analyze further cases out of this chart.



## FRICITION OPENING

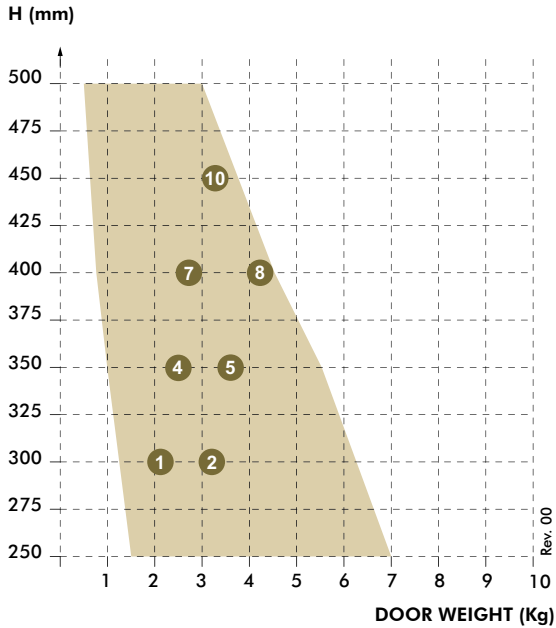

1 mechanism  
**KIARO S**

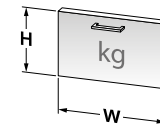
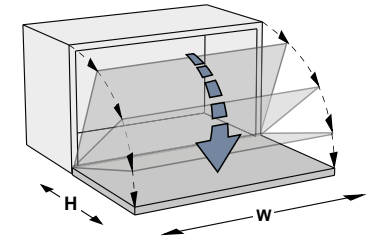

Door weight including the possible handle.

		<b>H</b> mm	<b>W</b> mm	<b>Weight</b> theoretical
1	Chipboard door thk 18mm	300	600	2,1 kg
2	Chipboard door thk 18mm	300	900	3,2 kg
3	Chipboard door thk 18mm	300	1200	4,2 kg
4	Chipboard door thk 18mm	350	600	2,5 kg
5	Chipboard door thk 18mm	350	900	3,7 kg
6	Chipboard door thk 18mm	350	1200	4,9 kg
7	Chipboard door thk 18mm	400	600	2,8 kg
8	Chipboard door thk 18mm	400	900	4,2 kg
9	Chipboard door thk 18mm	400	1200	5,6 kg
10	Chipboard door thk 18mm	450	600	3,2 kg
11	Chipboard door thk 18mm	450	900	4,8 kg
12	Chipboard door thk 18mm	450	1200	6,3 kg
13	Chipboard door thk 25mm	375	600	3,7 kg
14	Chipboard door thk 25mm	375	900	5,5 kg
15	MDF door thk 18mm	300	900	3,9 kg
16	MDF door thk 18mm	350	1200	5,9 kg
17	MDF door thk 18mm	400	900	5,0 kg
18	MDF door thk 18mm	400	1200	6,8 kg
19	Chipb. 18mm + glass 4mm	350	900	7,2 kg
20	Chipb. 18mm + glass 4mm	400	900	7,9 kg

Weight considering: Chipboard 650 Kg/m<sup>3</sup> and MDF 780 Kg/m<sup>3</sup>.

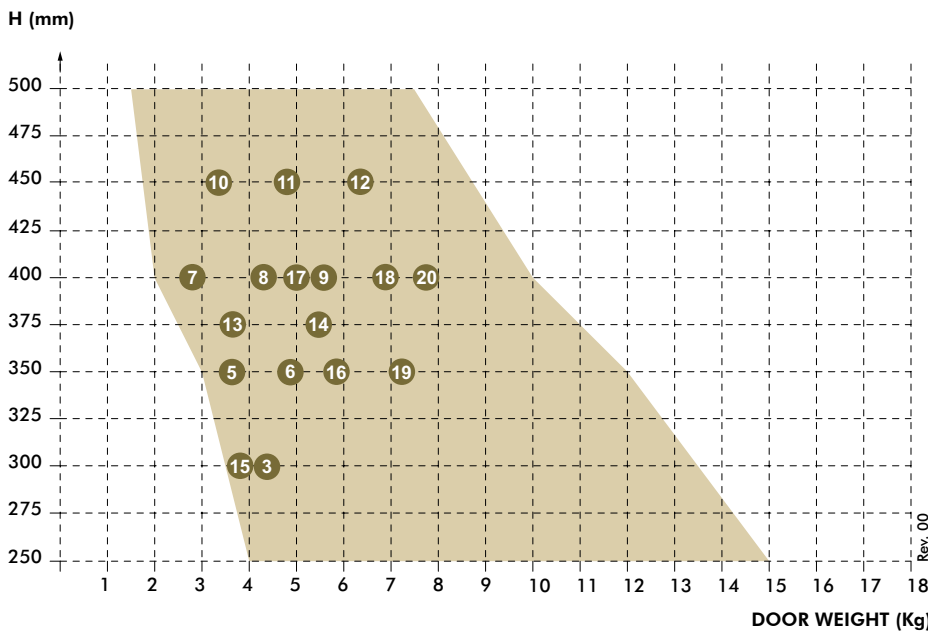

2 mechanisms  
**KIARO S**

These are experimental results to be checked by the customer.

In accordance with the actual European regulation, we suggest where possible to use two KIARO mechanisms for each door. Our technical department is at your disposal to analyze further cases out of this chart.

[Back to table of contents](#)



# OPENING SYSTEMS FOR LIFT UP AND DROP DOWN DOORS

## MECHANISM INSTALLATION

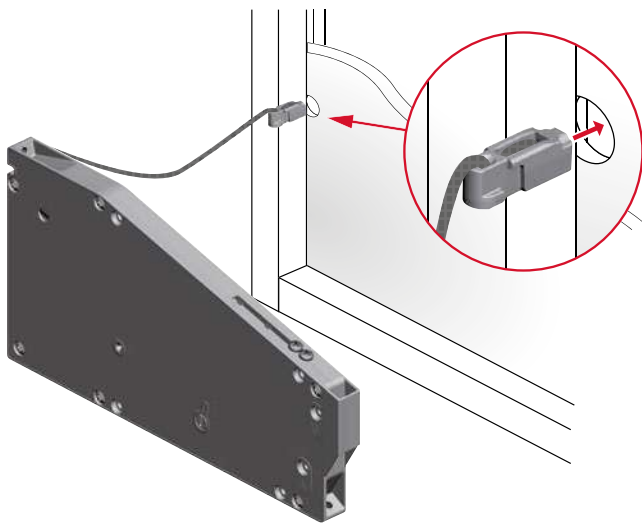

## UNHANDED MECHANISM

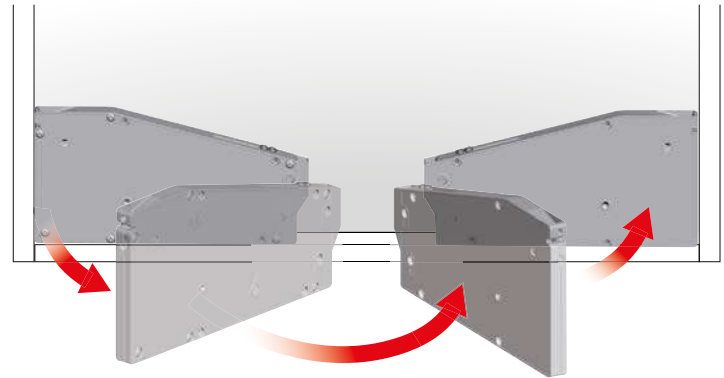

## MECHANISM FIXING

On the bottom and on the side panel with screws

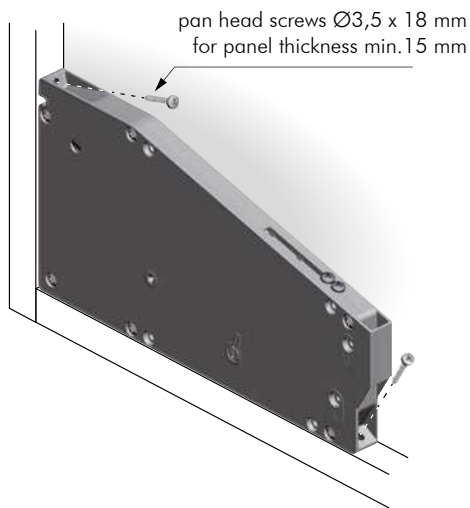

On the back panel with screws

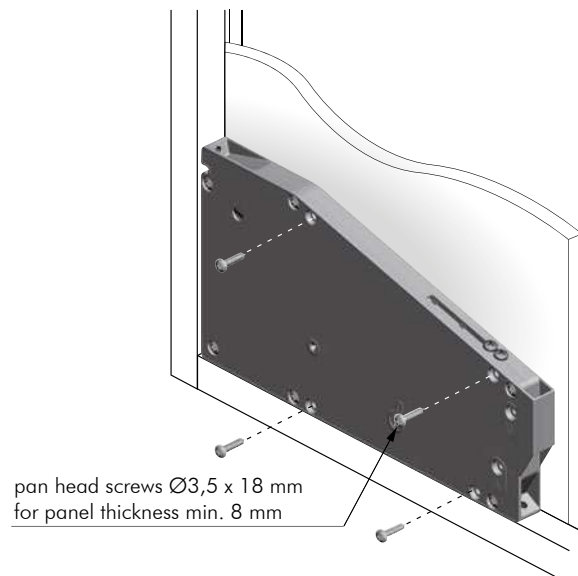

On the bottom and on the side panel with pin and screws

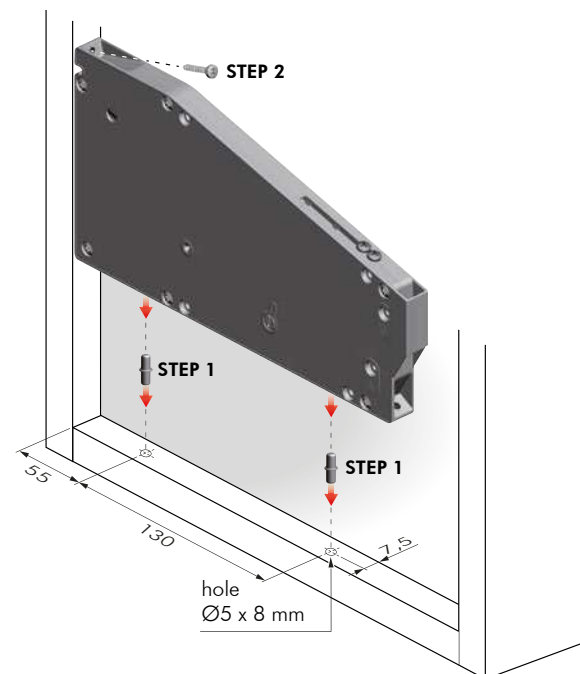
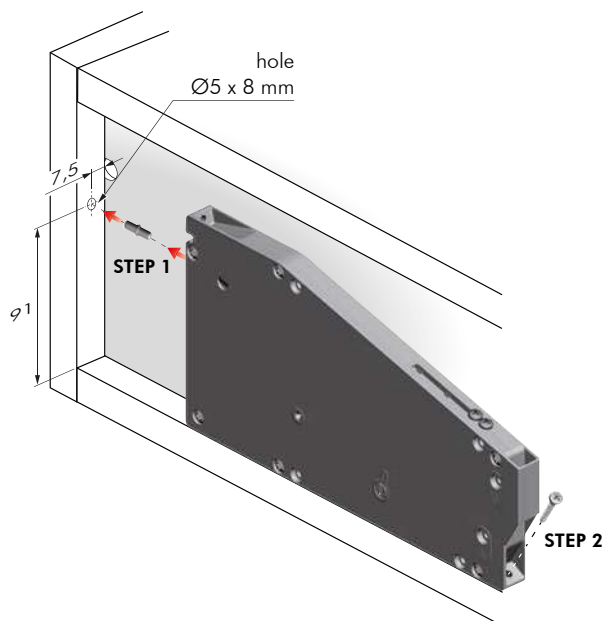

[Back to table of contents](#)



## BRACKETS INSTALLATION

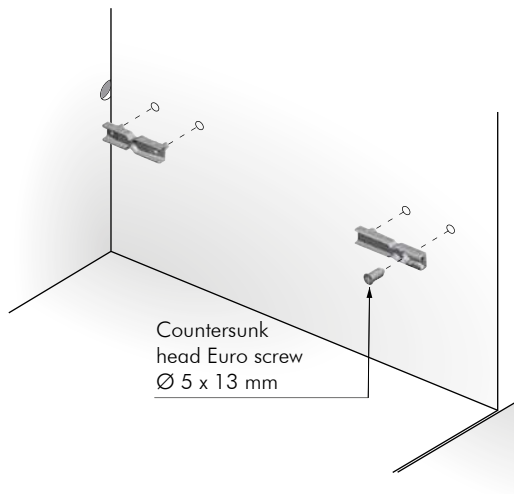

## WIRE INSTALLATION

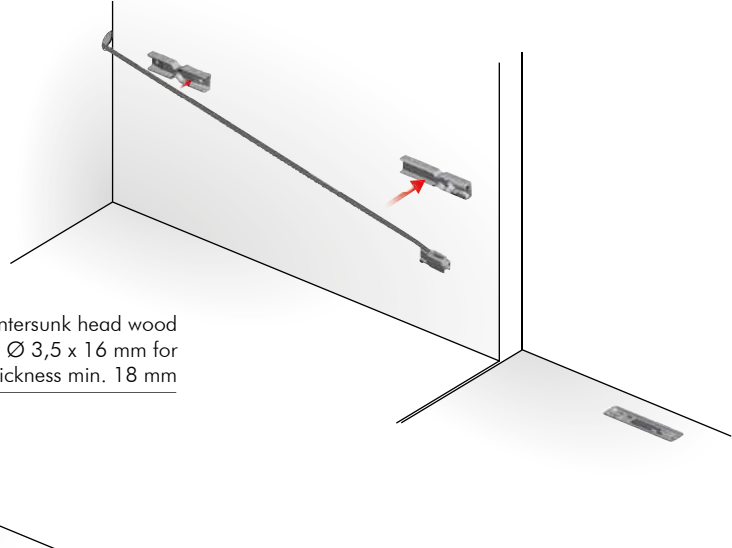

## WIRE INSERTION ONTO THE DOOR BRACKET

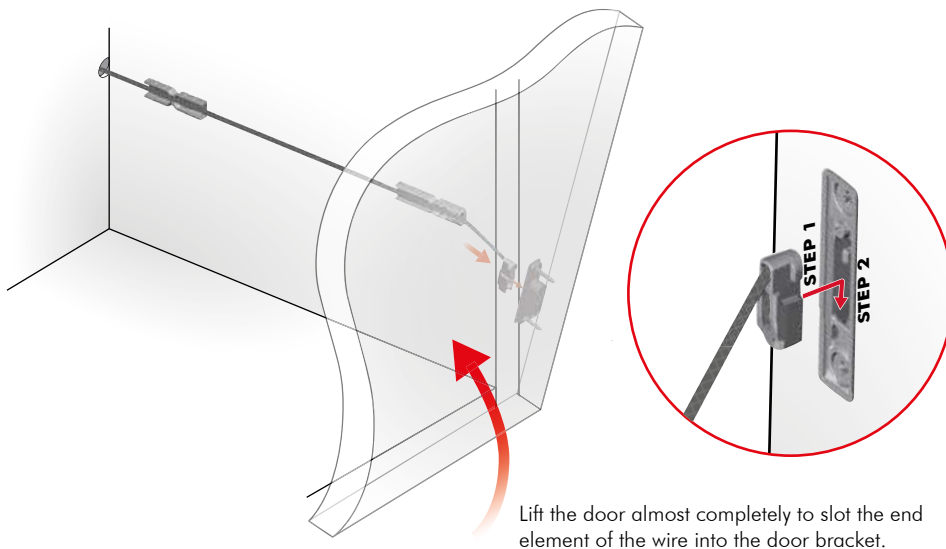

### STEP 1



### STEP 2



## COVER CAP AND ALUMINIUM LATERAL PROFILE INSERTION

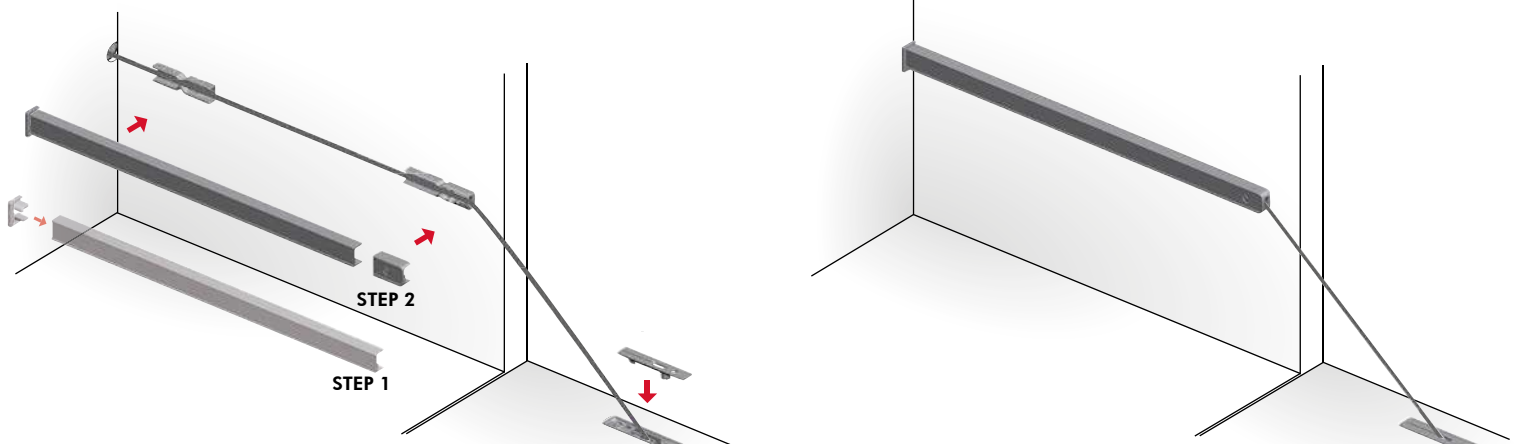

Place the cover cap on the door bracket before lifting the door.

## DOOR OPENING ANGLE ADJUSTMENT

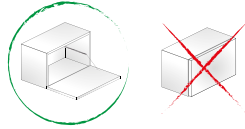
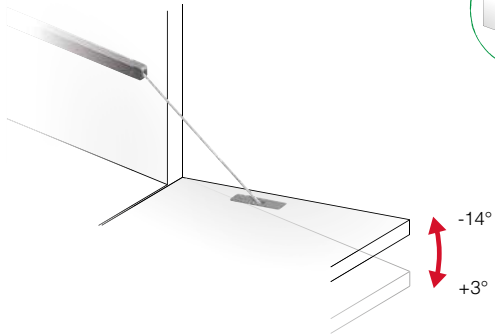

**VERY IMPORTANT:**  
The opening angle adjustment can be carried out only with open door.

### FROM THE INSIDE OF THE CABINET

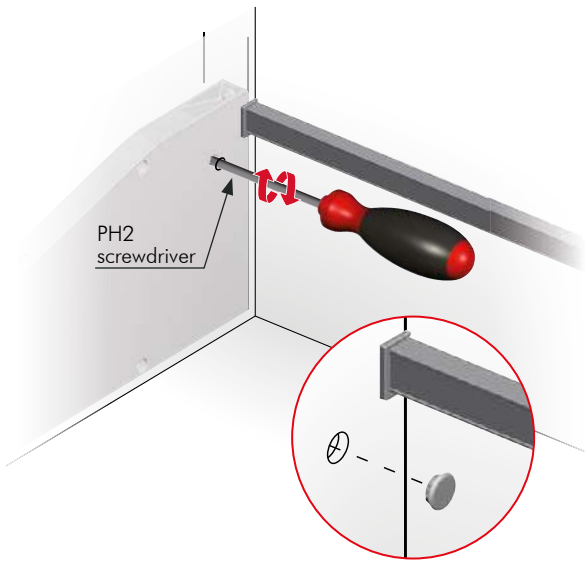

### FROM THE BACKSIDE OF THE CABINET

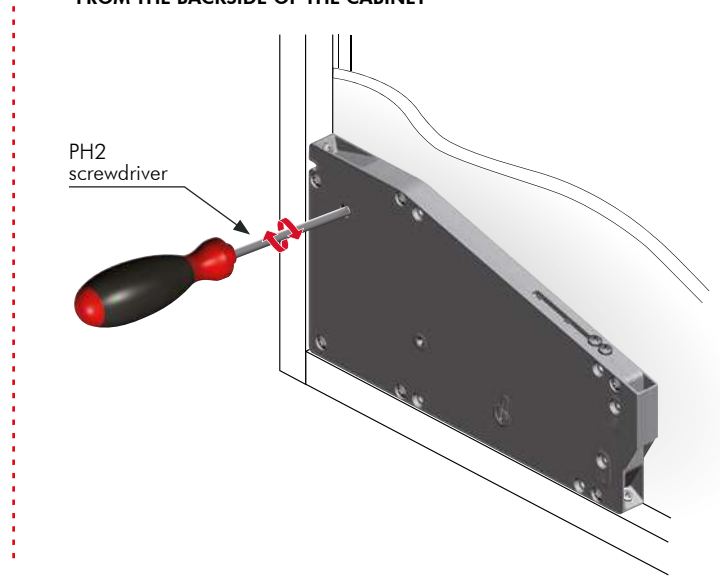

## ADJUSTMENT OF STRENGTH SETTINGS

Possibility to adjust the settings of the mechanism also upon completed assembly.  
For details refer to the related section.

**VERY IMPORTANT:**  
Before proceeding, make sure:

- 1) The door is completely closed.

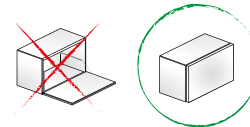

- 2) The mechanism is completely in position.

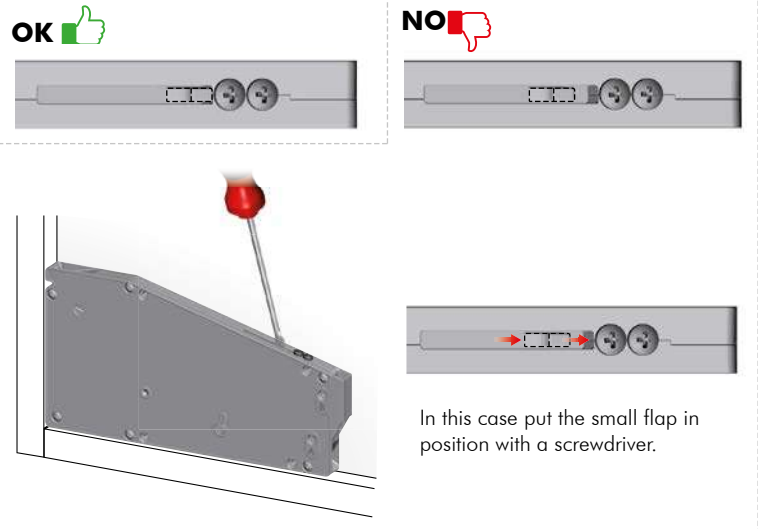



## INSTRUCTIONS FOR WIRE CUTTING

### INSERTION OF THE WIRE INTO THE END PART AND LOCKING WITH M3 GRUB SCREW

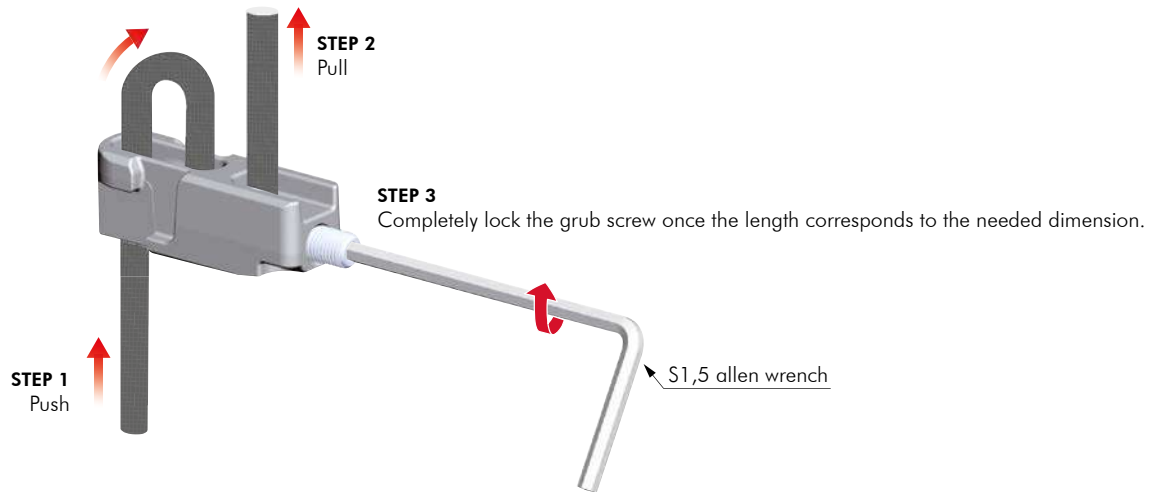

### WIRE CUTTING WITH UNMOUNTED MECHANISM

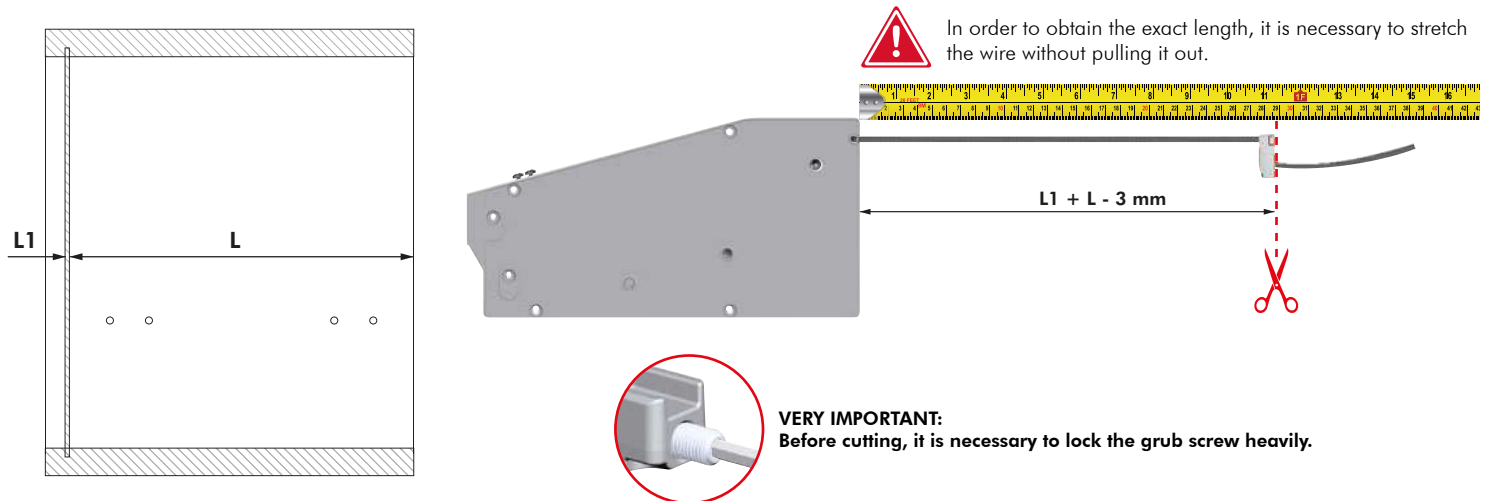

### WIRE CUTTING WITH MOUNTED MECHANISM

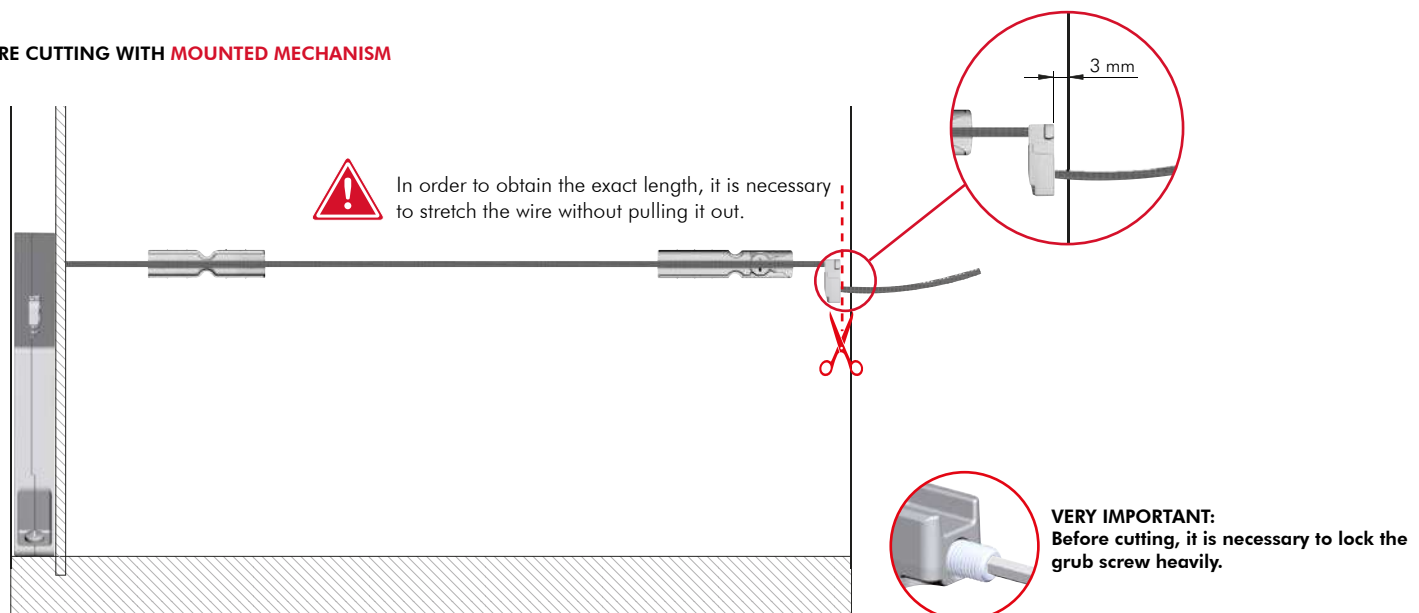



# OPENING SYSTEMS FOR LIFT UP AND DROP DOWN DOORS

KIT MECHANISM **KIARO** or **KIARO S** (with door brackets)

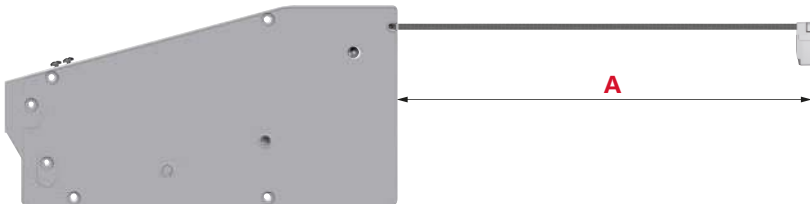
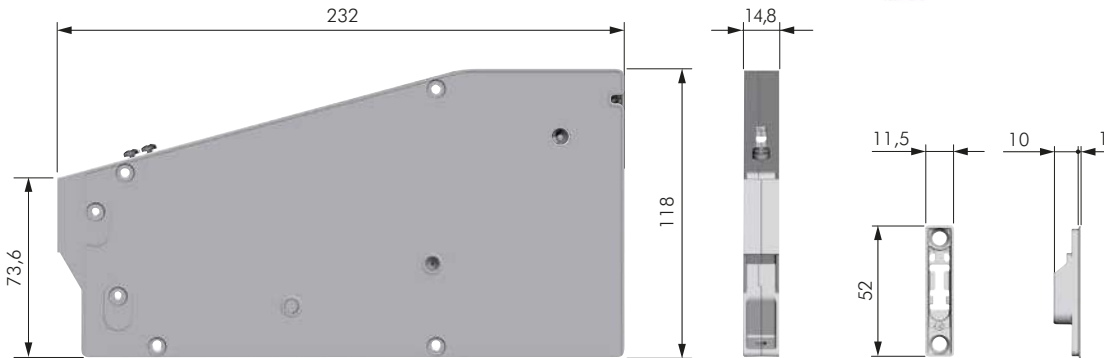

ZA	EP	ST	= 12 pcs.
			<b>A</b> (mm)
<b>KIARO</b>	<b>46006000YA</b>	<b>YQ</b>	600
<b>KIARO S</b>	<b>46106000YA</b>	<b>YQ</b>	

NOTE: Possibility to supply the wire with customized length (A).

8

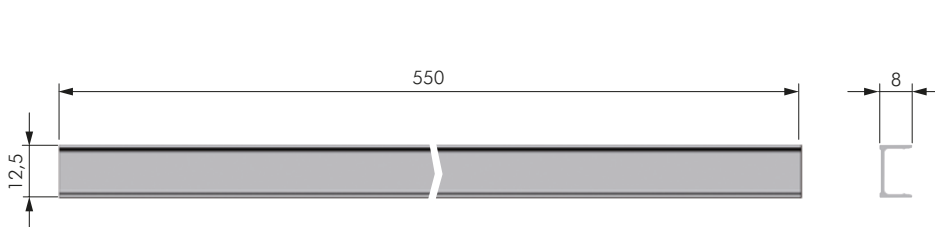

CUT TO SIZE RULE:

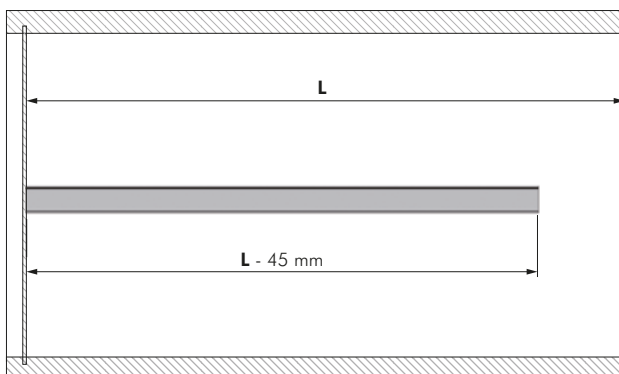

AL	= 12 pcs.
<b>46205500UT</b>	<b>FV</b>

NOTE: Possibility to supply the aluminium profile with customized length.

Finishes matching between cover caps and alu. profiles:

YA → UT  
YQ → FV

[Back to table of contents](#)





## ACCESSORIES FOR MECHANISM FIXING



 = Ø 3 mm  
   = PZ2  
 ST  = 10.000 pcs.

   
**60103150ZN**

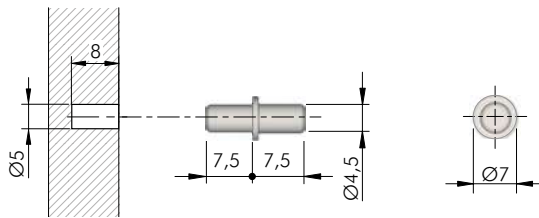

 = Ø 5 mm  
 ST  = 5000 pcs.

   
**10101010ZN**

## ACCESSORY FOR DOOR BRACKET FIXING



 = Ø 3 mm   
   = PZ2  
 ST  = 10.000 pcs.

   
**60101390ZN**

## ACCESSORY FOR LOCKING THE GRUB SCREW



 = S1,5  
 ST  = 1000 pcs.

   
**62501050ZN**

## KIARO WITH KIMANA HINGE

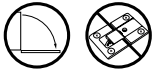

### BACK-PANEL DRILLING OPERATIONS

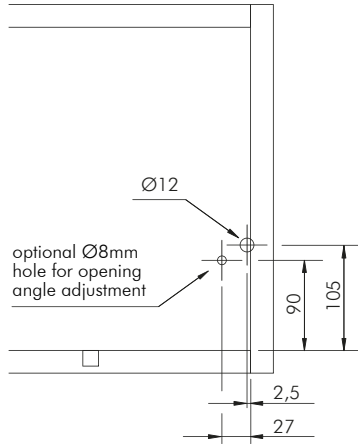

### SIDE-PANEL DRILLING OPERATIONS

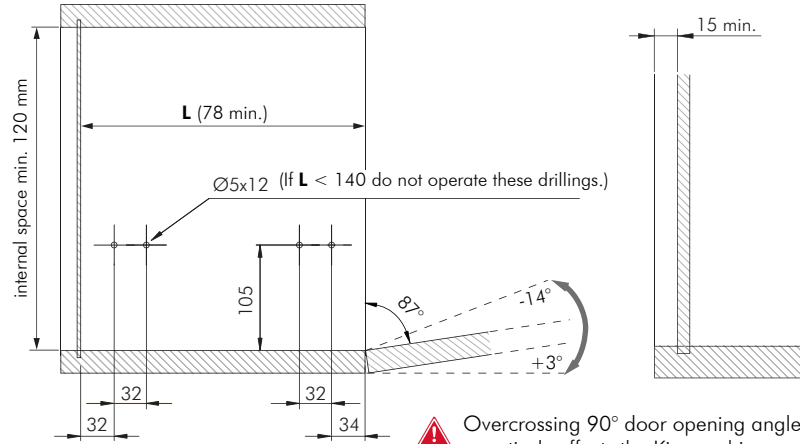

⚠ Overcrossing 90° door opening angle, negatively affects the Kimana hinges.



In case of door without handles it is recommended to use **K Push Tech with buffer**.

### DOOR PANEL DRILLING OPERATIONS

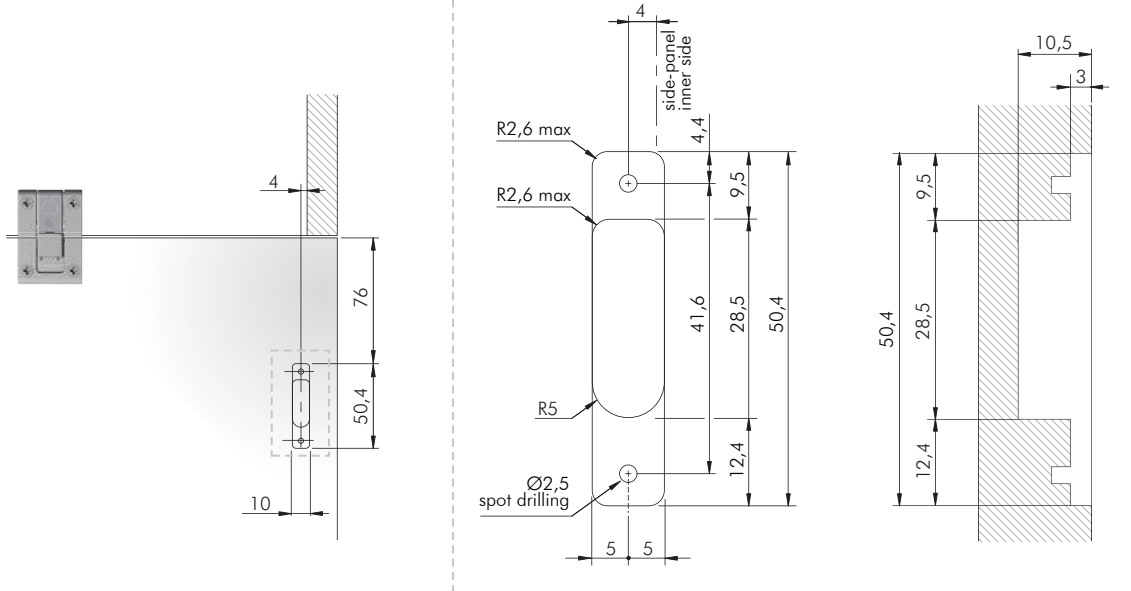

8

## KIARO WITH STANDARD UNSPRUNG HINGES



In case the hinges to be installed are not KIMANA hinges, please contact our technical department to receive the correct drilling plan. It is necessary to indicate all the values requested in the following diagram:

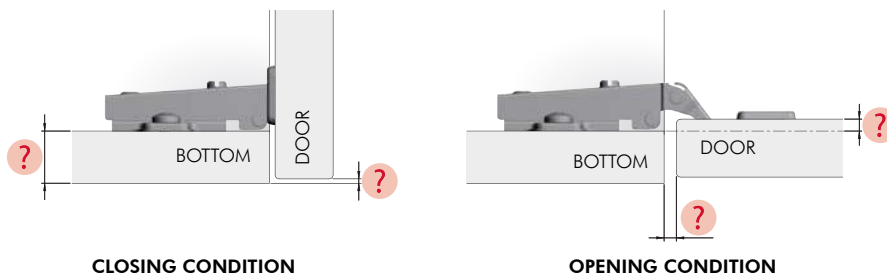

CLOSING CONDITION

OPENING CONDITION



## KIARO LED



The mechanism can be supplied with an integrated device operating as an on-off switch for the internal light, coordinated with the door opening and closing, adding a homely ambiance and a touch of luxury.

The lighting device of KIARO is to be installed on the concealed mechanism and can work either for the lateral profile with integrated LED strip or for other lighting appliances placed inside the cabinet.

Thanks to this bespoke device, it is no longer required to make special drilling operations to install visible opening detectors.

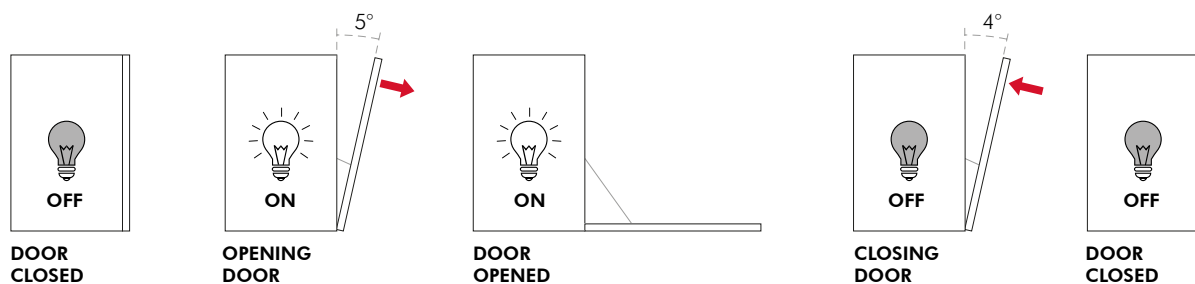



## COMPONENTS FOR APPLICATIONS WITH 1 KIARO LED

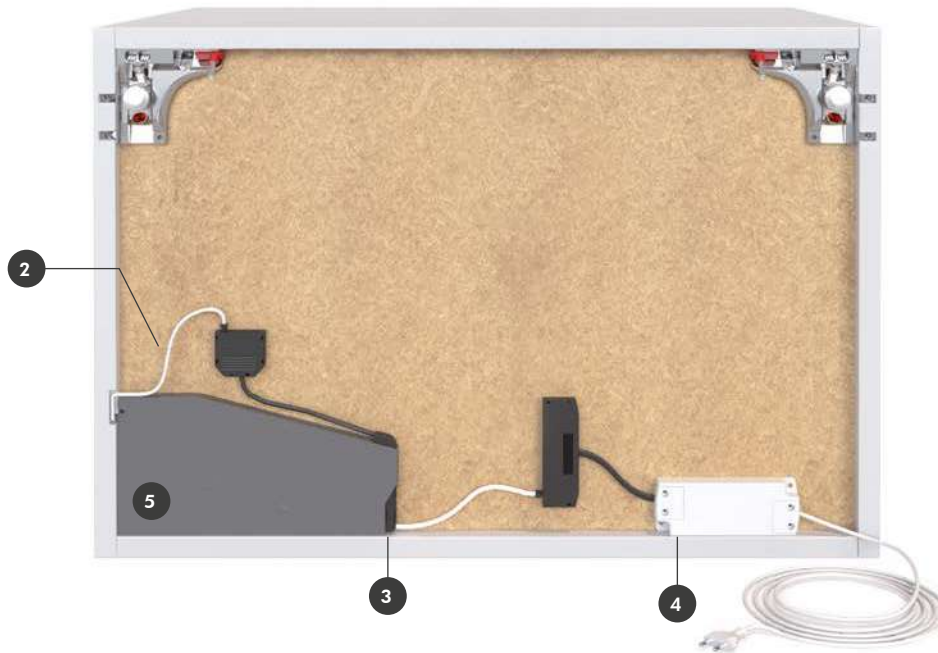

1 1 x KIARO LED ALUMINIUM PROFILE (pagina 8.80)  
1 x COVER CAPS SET (pagina 8.80)

2 1 x LED FLEXIBLE STRIP (pagina 8.81)

3 1 x SENSOR FOR KIARO LED (pagina 8.80)

4 1 x CHARGER (pagina 8.81)

5 KIT MECHANISM KIARO or KIARO S (with door brackets) (pagina 8.74)



For the correct mechanism settings please refer to the dedicated section.



## COMPONENTS FOR APPLICATIONS WITH 2 KIARO LED

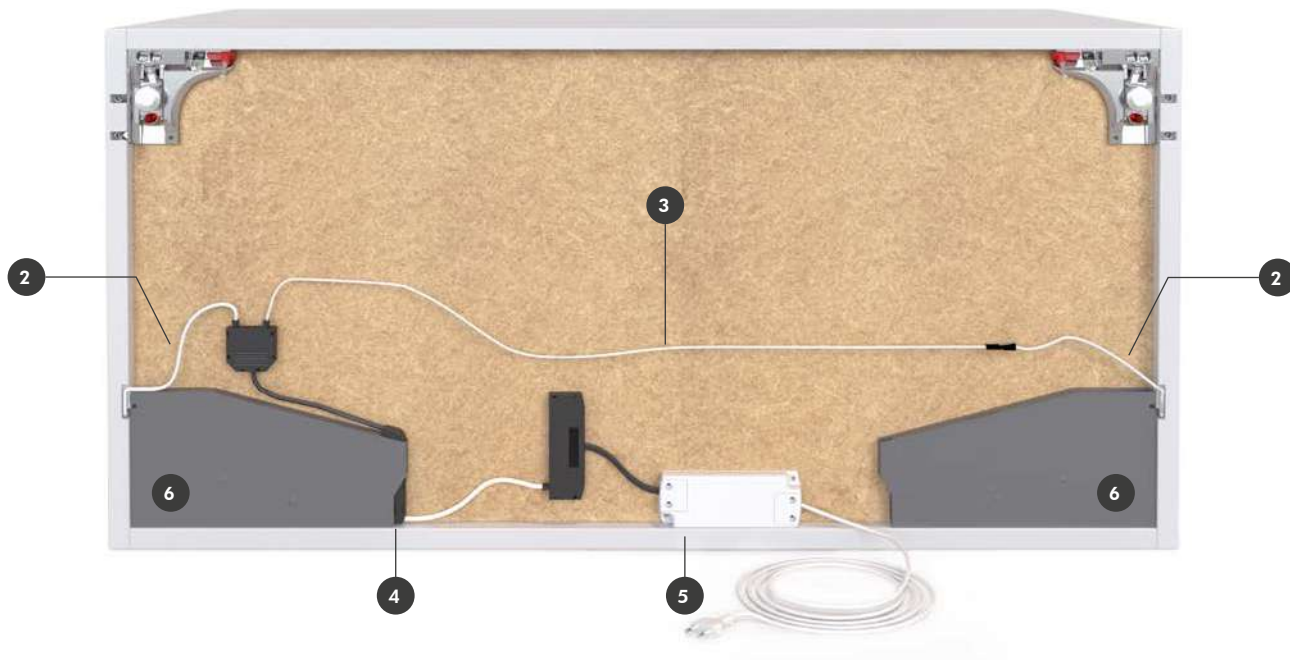
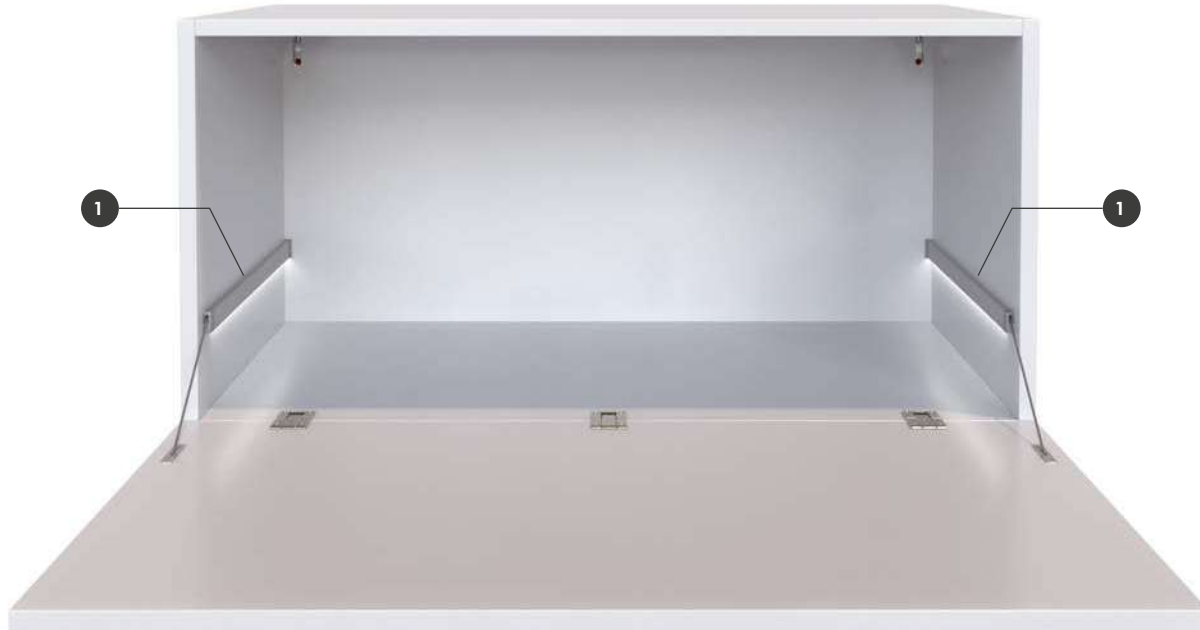

1 2 x KIARO LED ALUMINIUM PROFILE (pagina 8.80)  
1 x COVER CAPS SET (pagina 8.80)

2 2 X LED FLEXIBLE STRIP (pagina 8.81)

3 1 X EXTENSION CABLE (pagina 8.82)

4 1 X SENSOR FOR KIARO LED (pagina 8.80)

5 1 X CHARGER (pagina 8.81)

6 KIT MECHANISM KIARO or KIARO S (with door brackets) (pagina 8.74)



For the correct mechanism settings please refer to the dedicated section.

## KIARO LED ALUMINIUM PROFILE

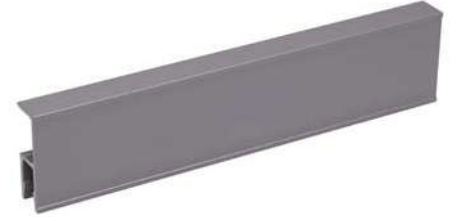
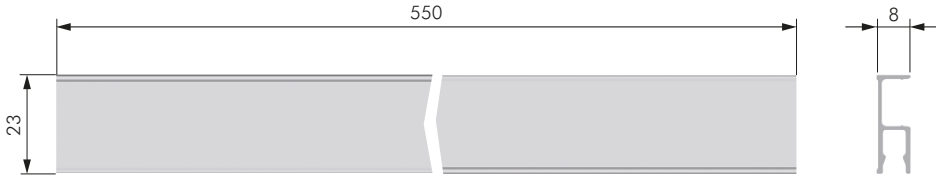

CUT TO SIZE RULE:

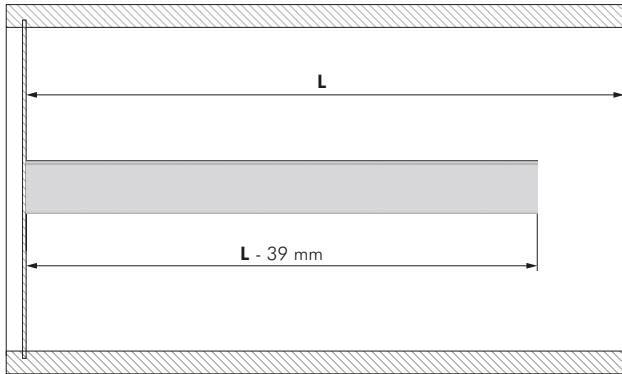

AL	= 12 pcs.
<b>46505500UT</b>	<b>FV</b>

NOTE: Possibility to supply the aluminium profile with customized length.

## COVER CAPS SET

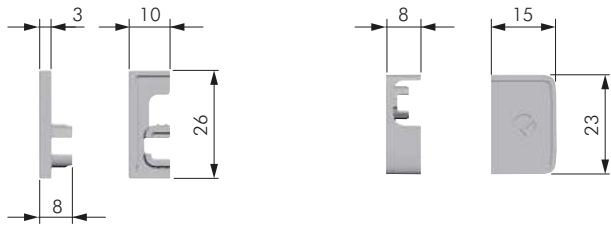

EP	= 1 pc.
<b>46303140EW</b>	<b>EE</b>

NOTE: Finishes matching between cover caps and alu. profiles:

**EW** → **UT**  
**EE** → **FV**

8

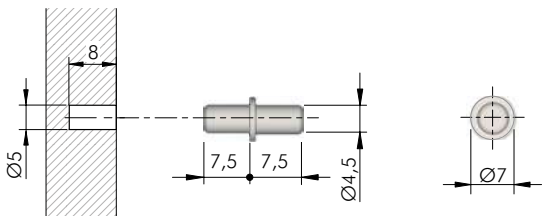

## SENSOR FOR KIARO LED

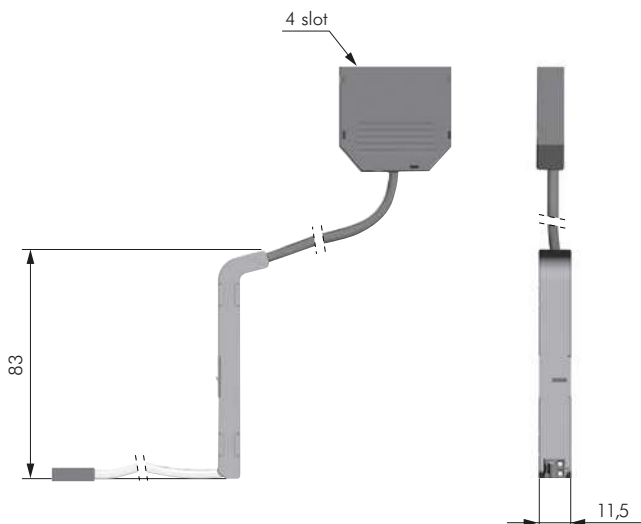

Maximum output: 30 Watt with light 12Vdc 60 Watt with light 24Vdc	
	= 12 pcs.
<b>4670600000</b>	



## LED FLEXIBLE STRIP

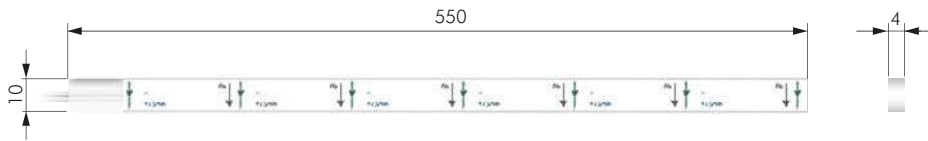

= 12 pcs.	
123 <b>46601000AB</b>	<b>LED Colour temperature</b> 4000 K

## CHARGER

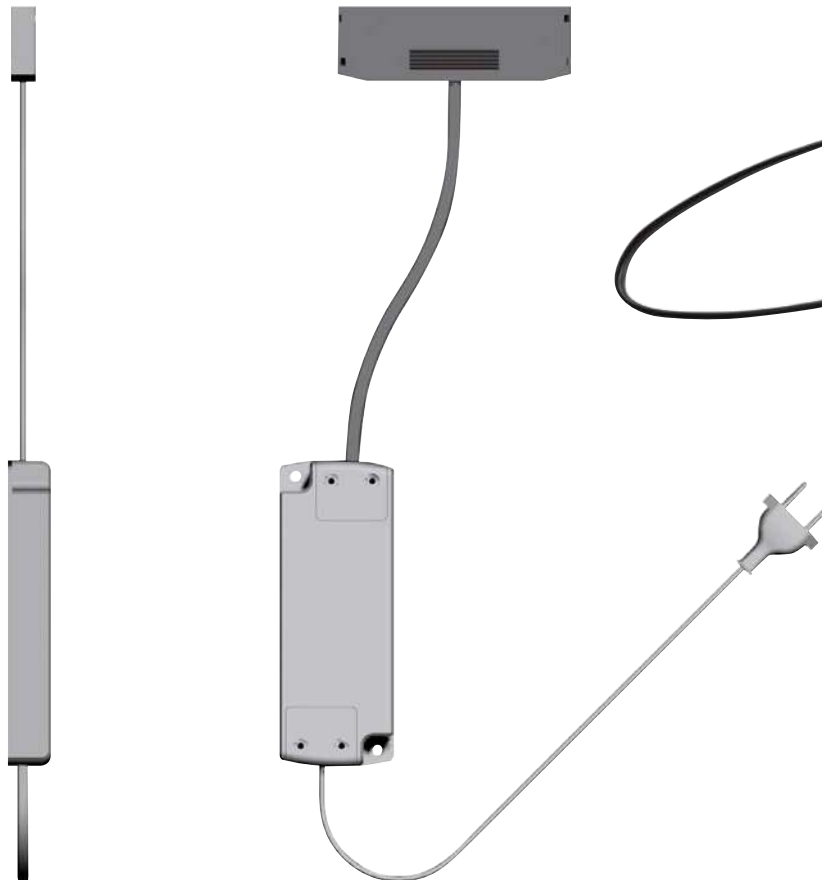

= 12 pcs.	
123 <b>4670702000</b>	<b>LED Colour temperature</b> 110-120 Vac USA - CANADA socket
<b>4670700000</b>	220-240 Vac EUROPEAN socket

8

The chargers images shown here are for illustrative purposes only.



## EXTENSION CABLE



Length: 2000 mm

 = 12 pcs.



4670601000

## CUSTOMER LIGHTING CONNECTORS



Length: 150 mm

Male connector

 = 12 pcs.



4670602000



Length: 150 mm

Female connector

 = 12 pcs.



4670603000





## KIARO LED INSTALLATION

HOW TO CUT ON SIZE AND INSTALL THE LED FLEXIBLE STRIP.

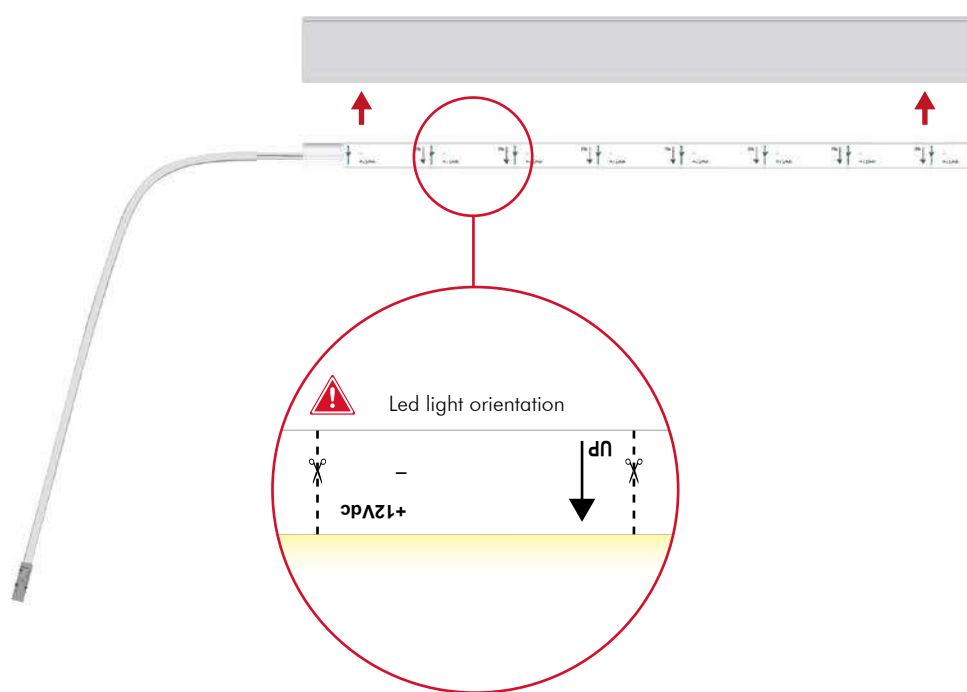
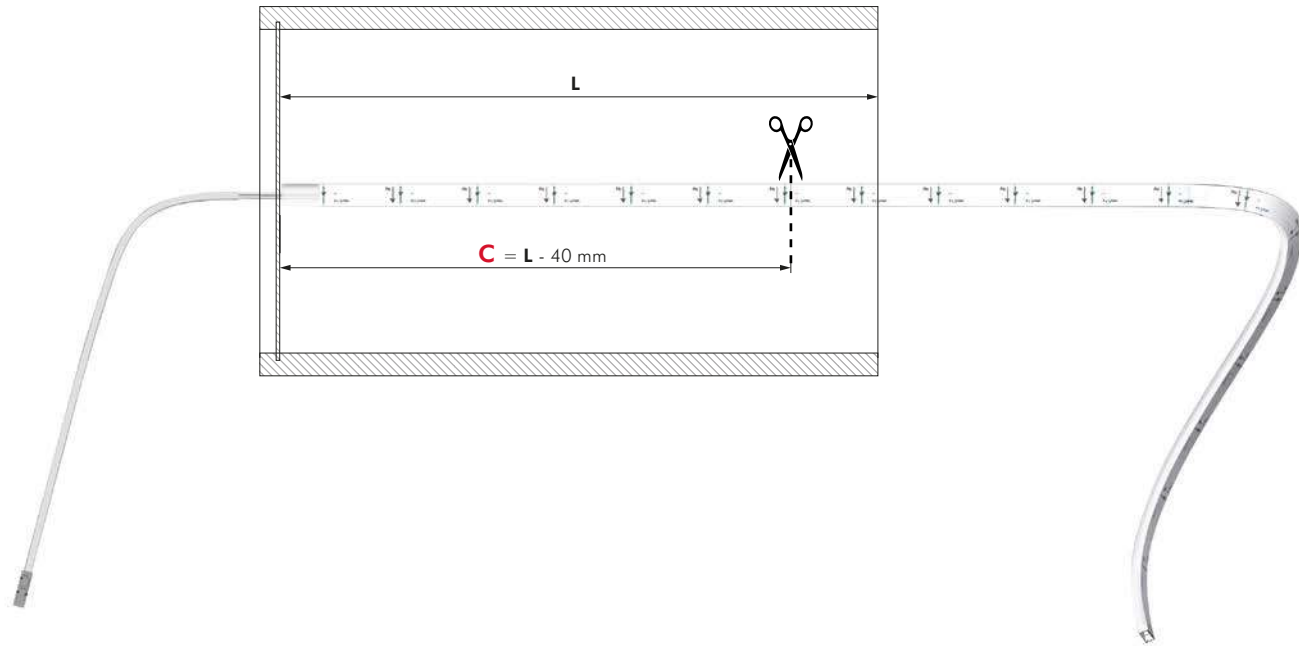



# OPENING SYSTEMS FOR LIFT UP AND DROP DOWN DOORS

LED STRIP ELECTRICAL WIRE INSERTION THROUGH THE BACKSIDE HOLE

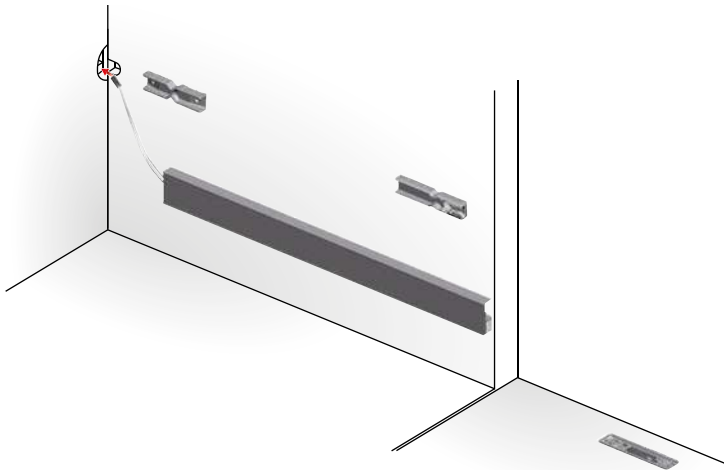

MECHANISM INSTALLATION

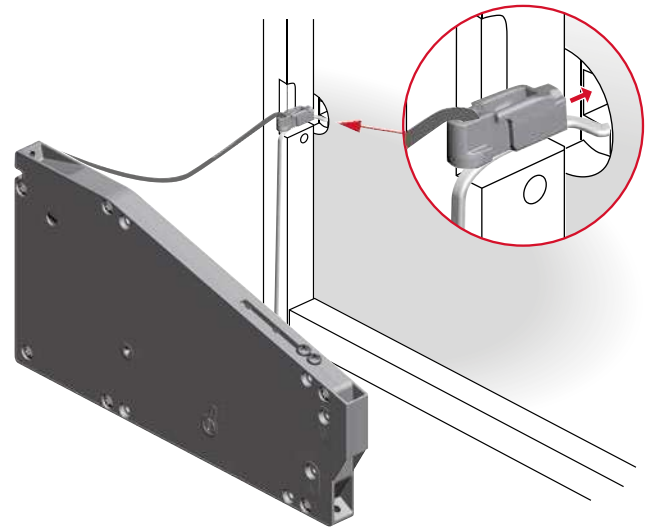

MECHANISM FIXING

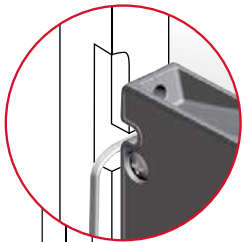

Pull the power cable of the led strip through the drilling spot on the cabinet side, before fixing the main mechanism.

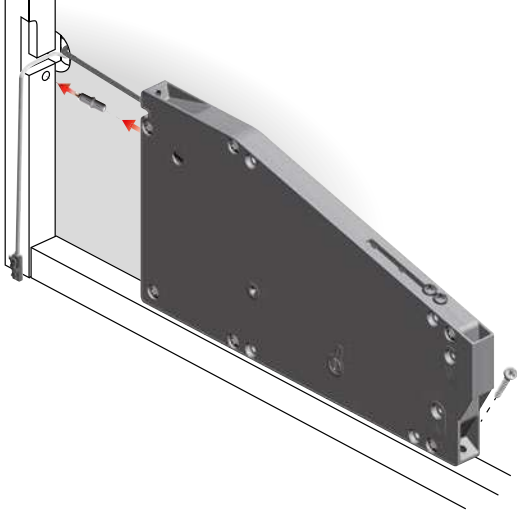

WIRE INSTALLATION

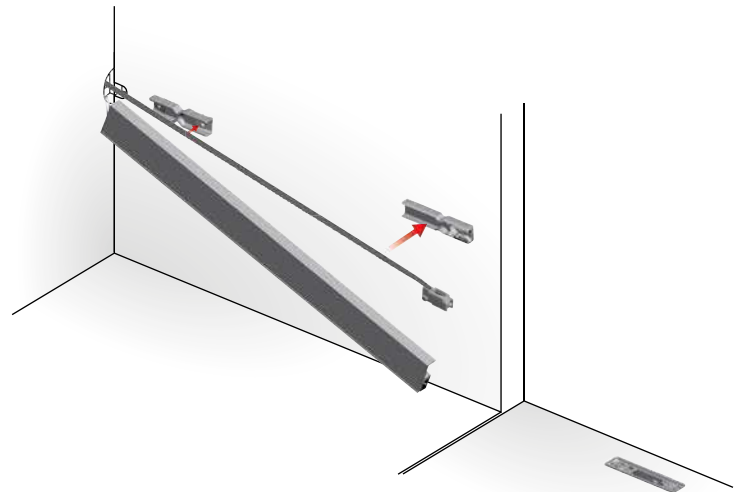

INSERTION OF THE BACKSIDE COVER FOR ALU. PROFILE

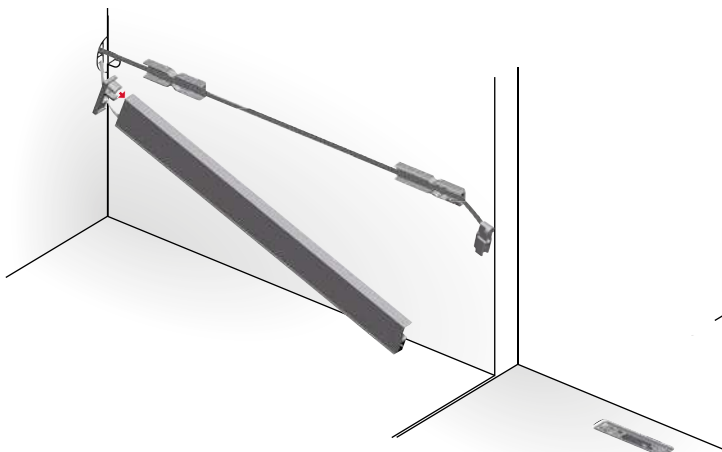

COVER CAPS AND ALUMINIUM LATERAL PROFILE INSERTION

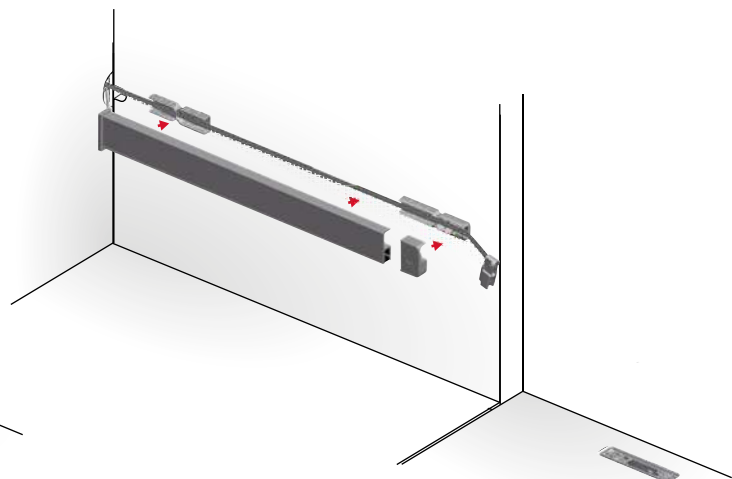

8



## WIRE INSERTION ONTO THE DOOR BRACKET

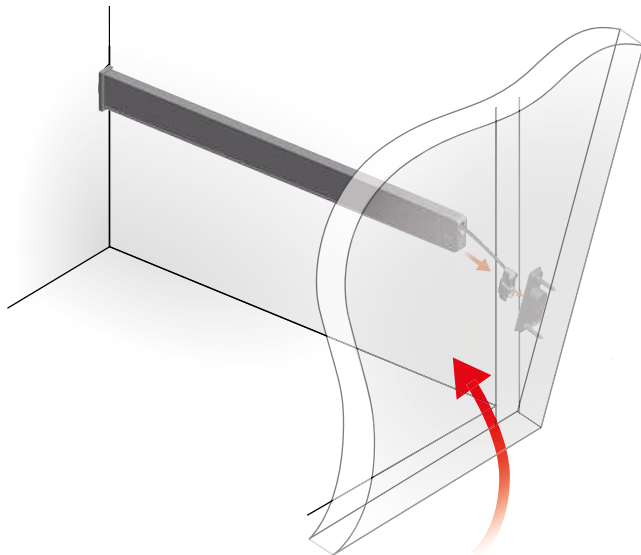

## COVER CAP FOR DOOR BRACKET INSERTION

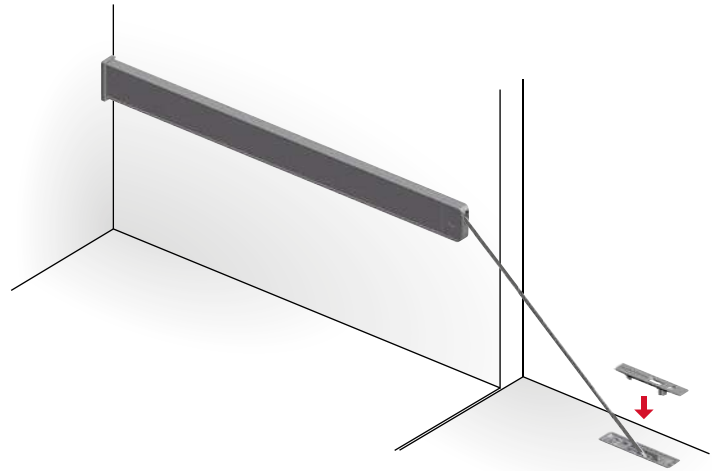

## SENSOR INSTALLATION

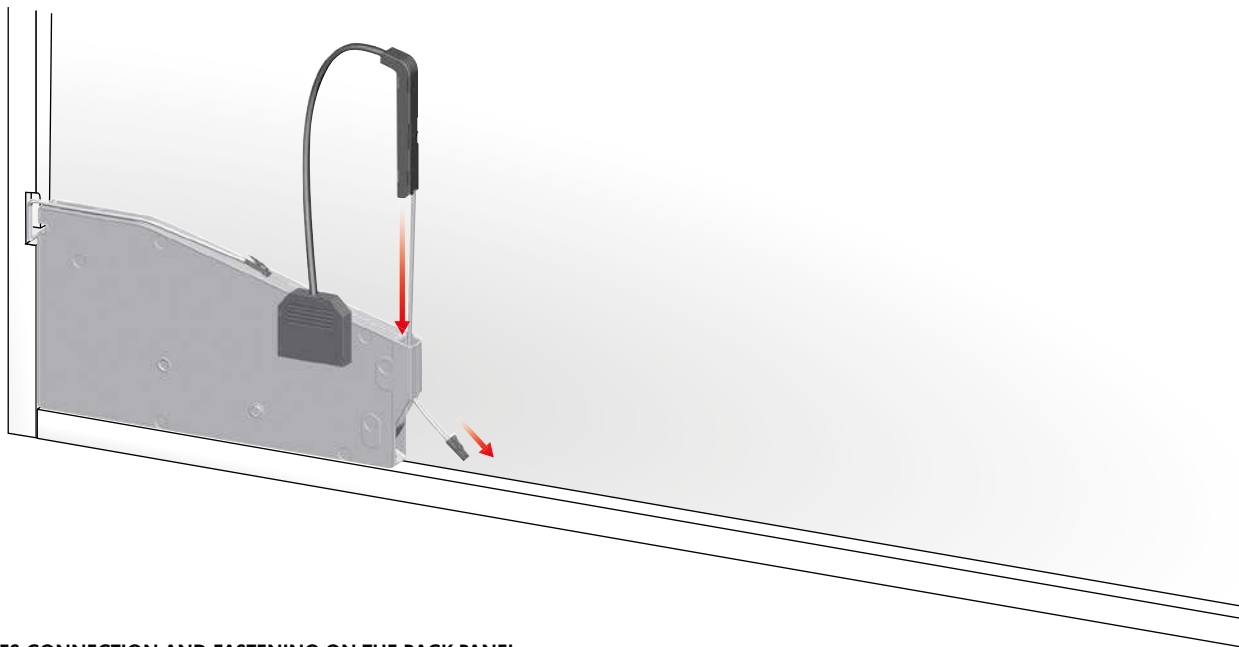

8

## DEVICES CONNECTION AND FASTENING ON THE BACK PANEL.

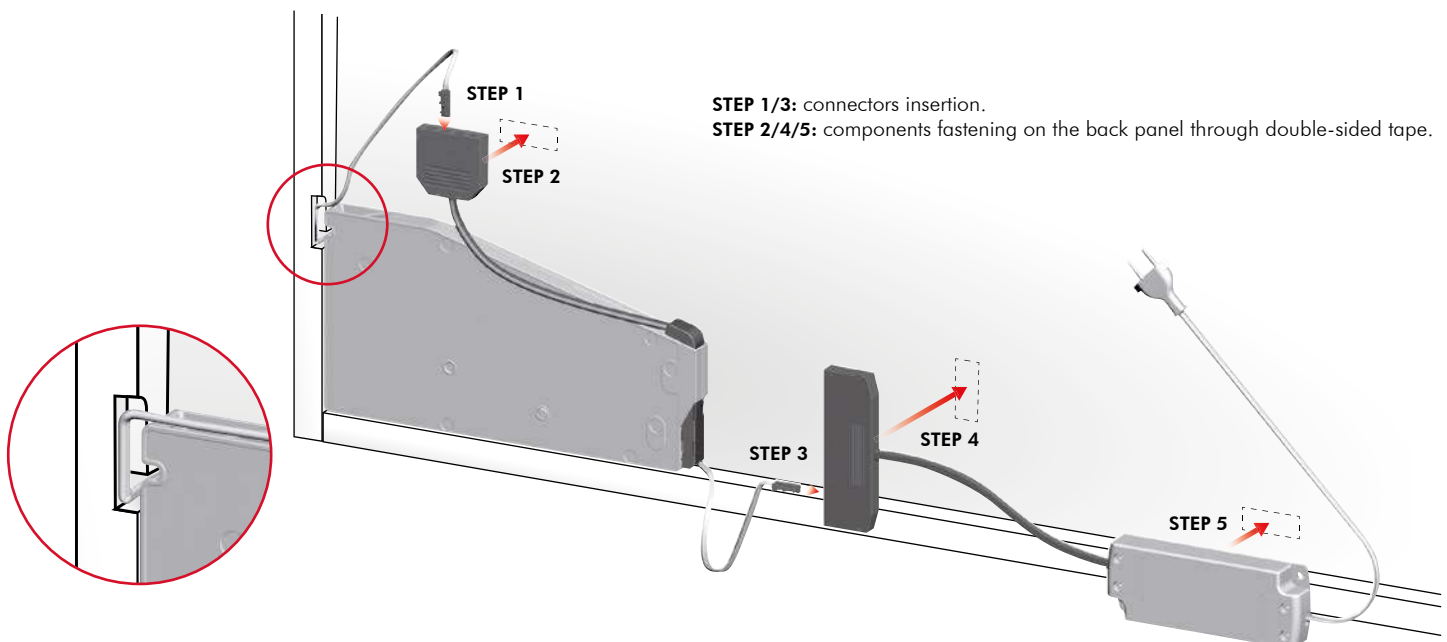



## EXTENSION CABLE CONNECTION WITH LED STRIP CONNECTORS

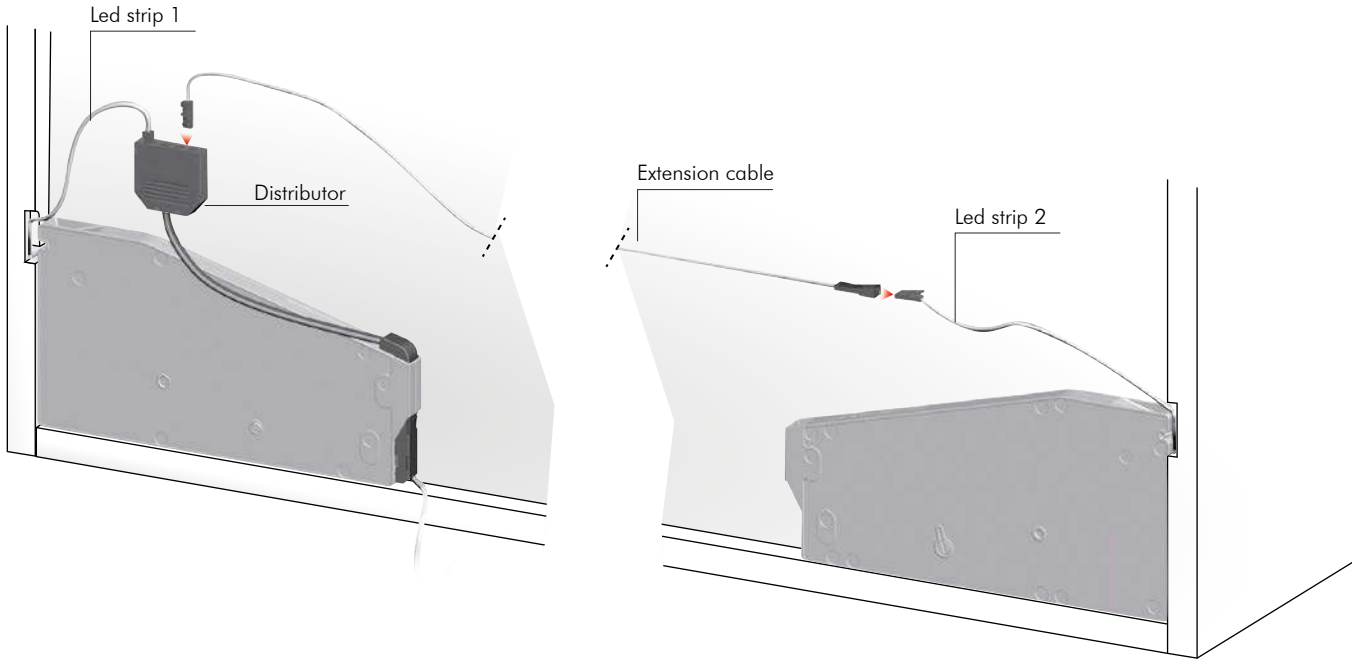



## KIARO WIRING DIAGRAM FOR CUSTOMER LIGHTING

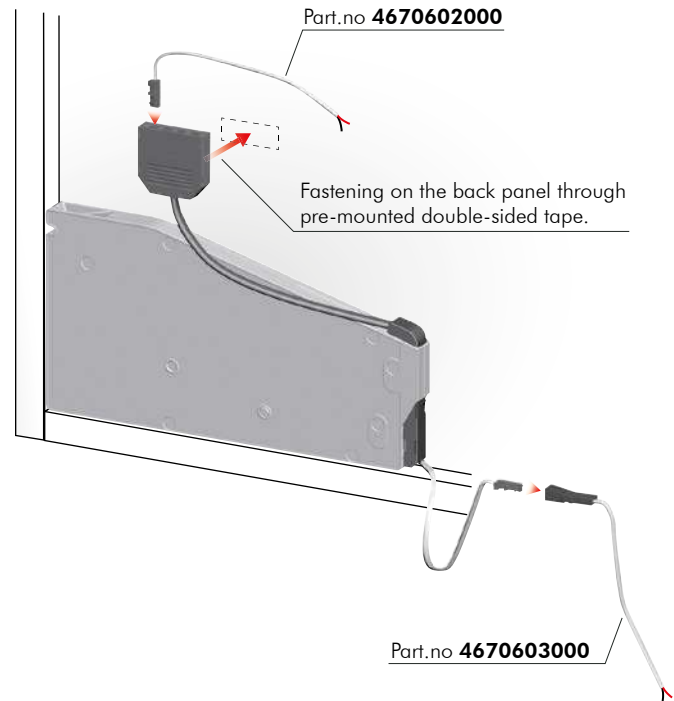
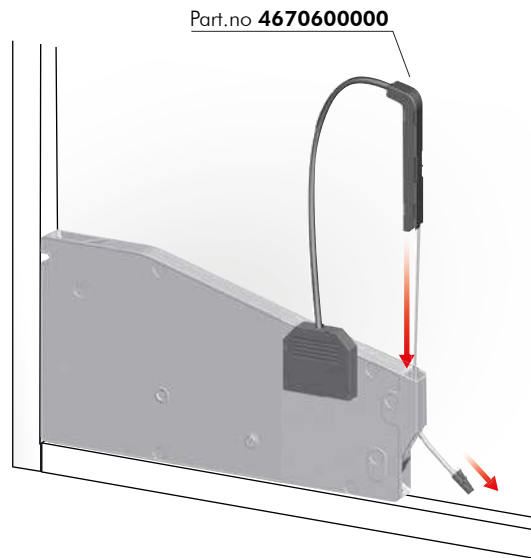

Each door must be connected to only one sensor, no matter how many mechanism are installed.

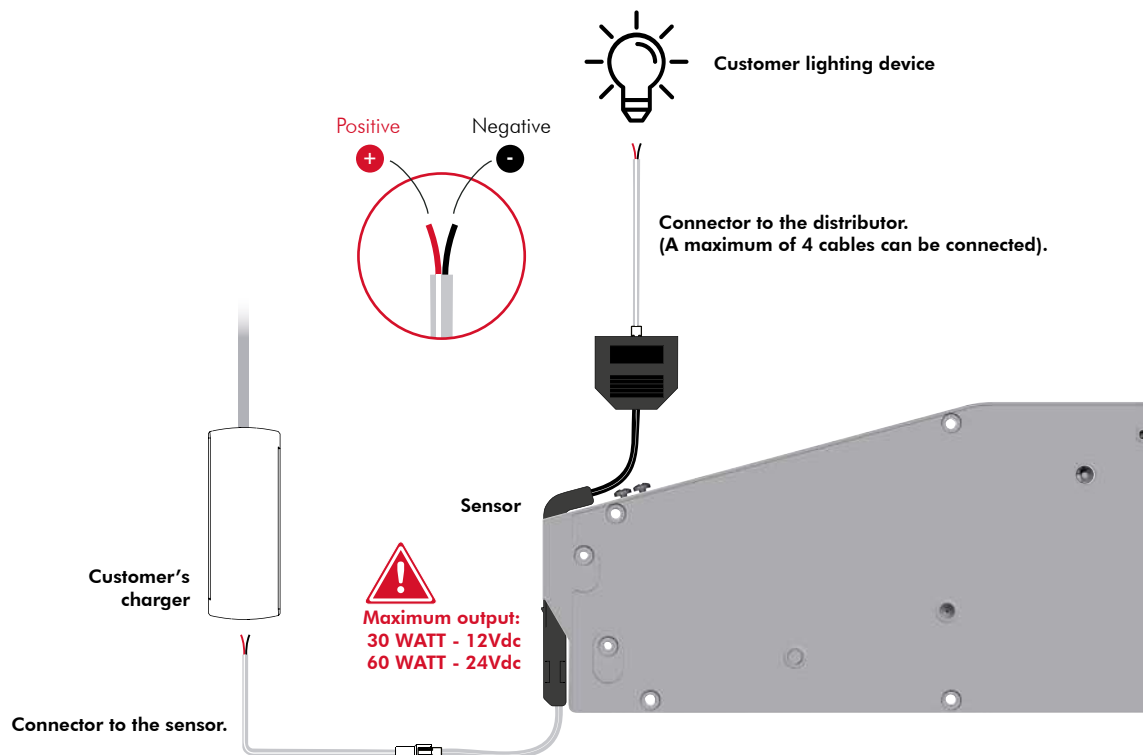

## KIARO LED WITH KIMANA HINGE

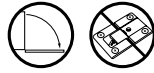

### BACK-PANEL DRILLING OPERATIONS

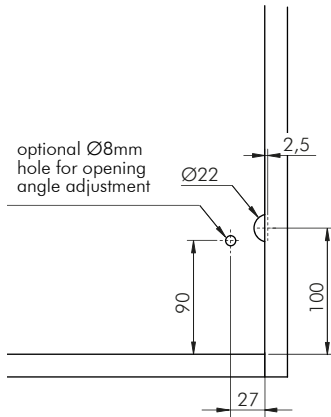

In case of door without handles it is recommended to use **K Push Tech with buffer**.

### SIDE-PANEL DRILLING OPERATIONS

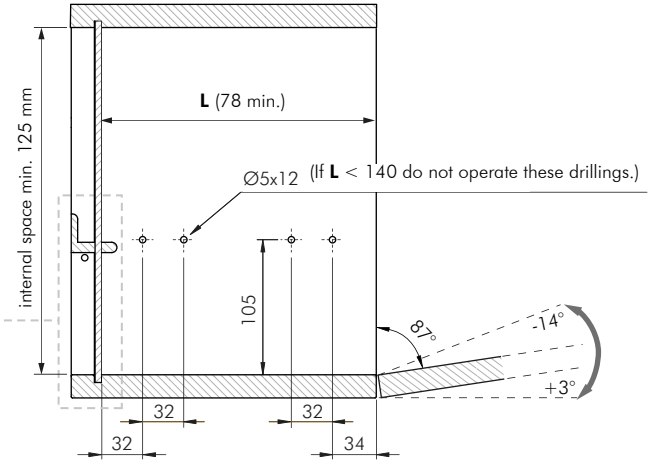
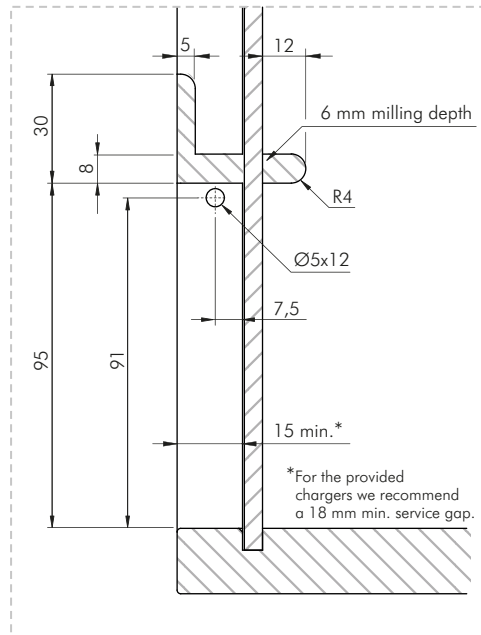

**⚠** Overcrossing  $90^\circ$  door opening angle, negatively affects the Kimana hinges.

### DOOR PANEL DRILLING OPERATIONS

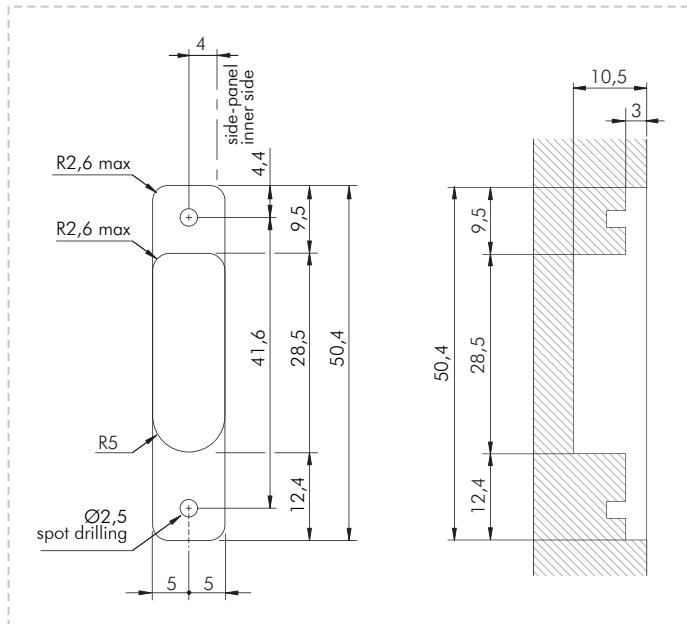
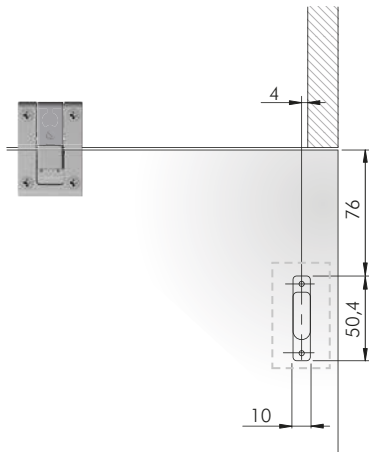

## KIARO LED WITH STANDARD UNSPRUNG HINGES



In case the hinges to be installed are not KIMANA hinges, please contact our technical department to receive the correct drilling plan. It is necessary to indicate all the values requested in the following diagram:

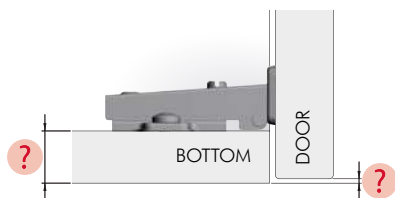

CLOSING CONDITION

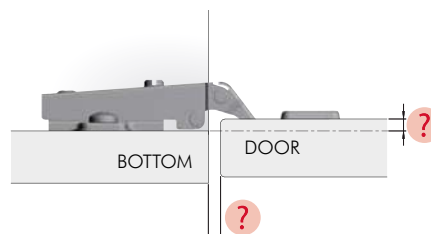

OPENING CONDITION



## KIARO WITH SCREW FIXING DOOR BRACKET WITHOUT MILLING ON THE DOOR

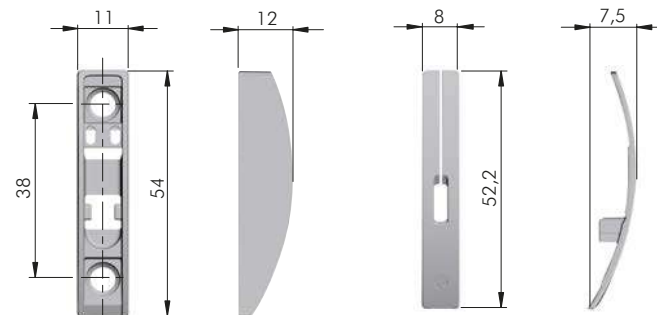
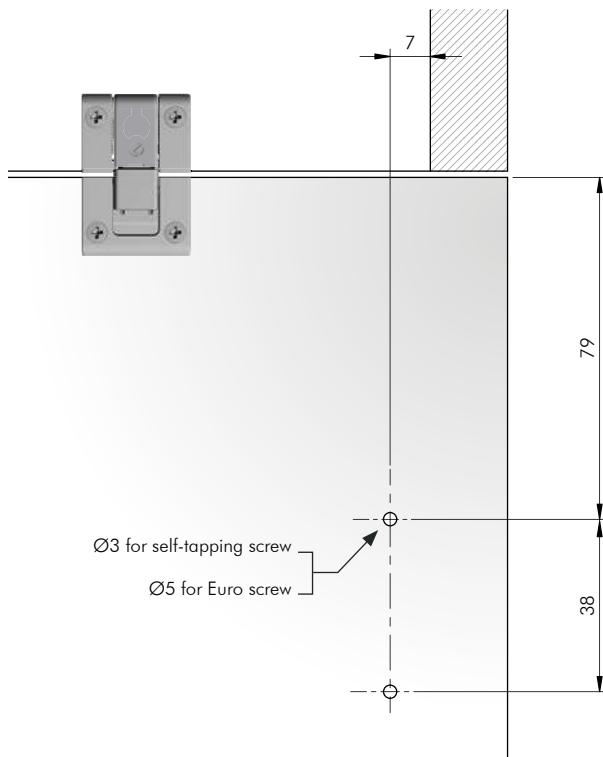

= Ø 3 mm, Ø 5 mm  
 = 20 pcs.

<b>49503500YQ</b>	EE	YQ	
<b>49503500YA</b>	EW	YA	
<b>49503510YQ</b>	LD	YQ	
<b>49503510YA</b>	AB	YA	

## FIXING ACCESSORIES

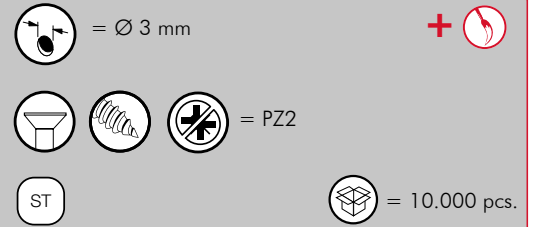
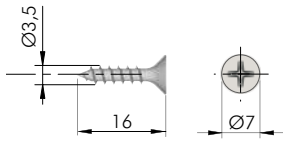

60101390ZN

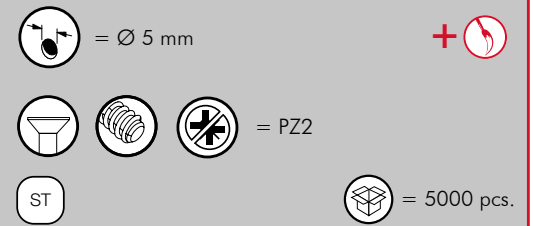
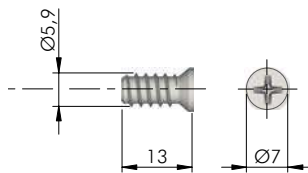

60503050ZN

8

### DOOR BRACKET INSTALLATION

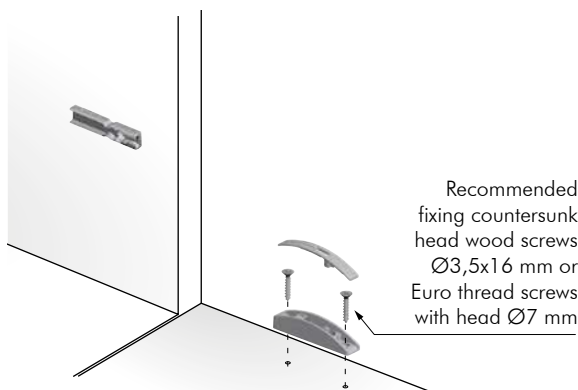

### WIRE INSERTION ONTO THE DOOR BRACKET

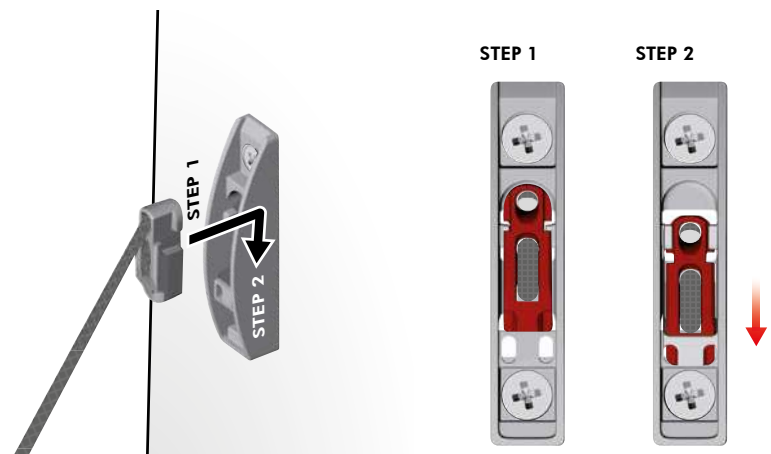

Lift the door almost completely to slot the end element of the wire into the door bracket.





## DOOR BRACKETS COVER CAP INSERTION

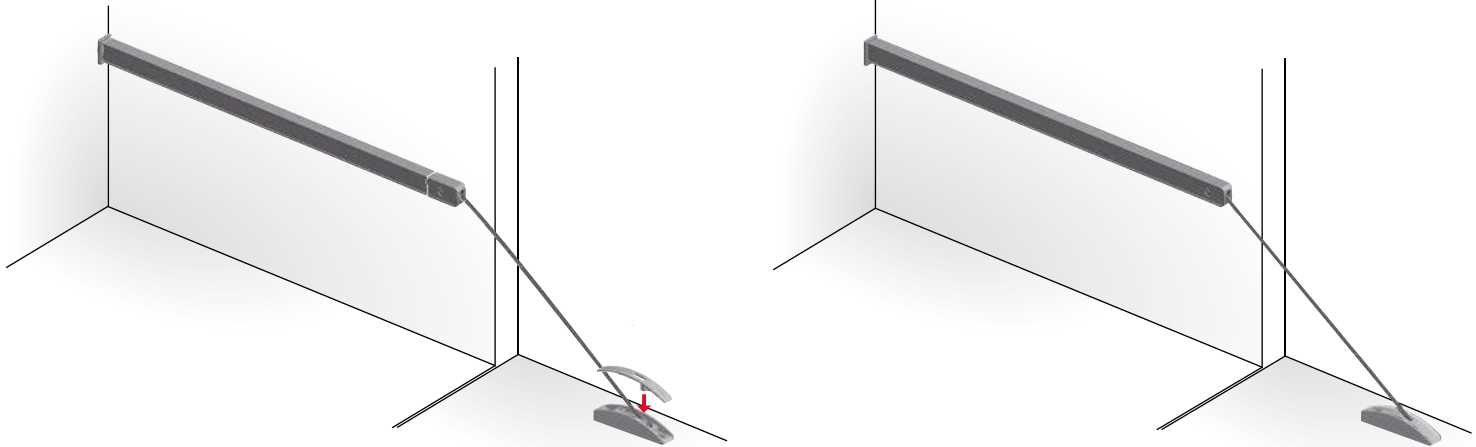

Place the cover cap on the door bracket before lifting the door.

## INSTRUCTIONS FOR WIRE CUTTING

### WIRE CUTTING WITH UNMOUNTED MECHANISM

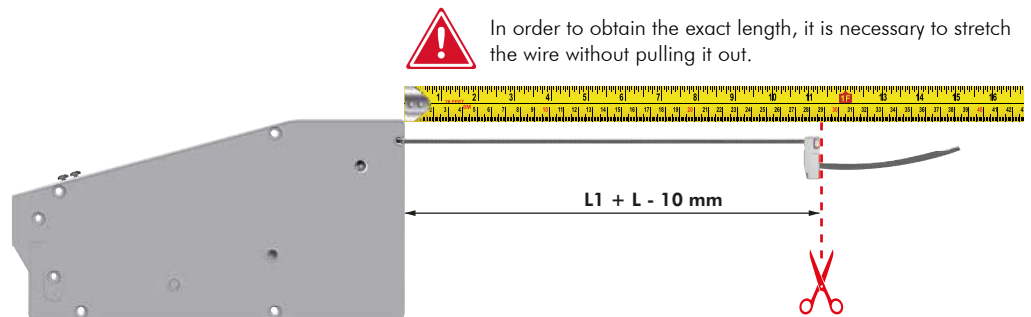
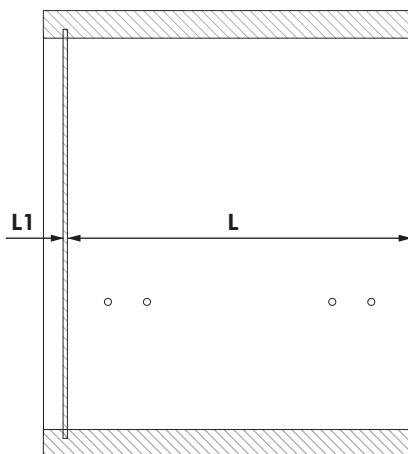

**VERY IMPORTANT:**  
Before cutting, it is necessary to lock the grub screw heavily.

### WIRE CUTTING WITH MOUNTED MECHANISM

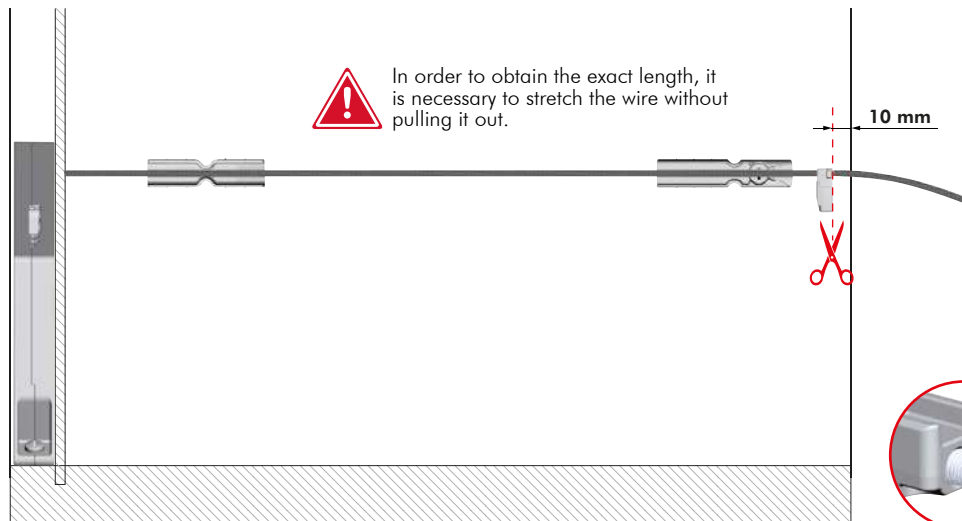

**VERY IMPORTANT:**  
Before cutting, it is necessary to lock the grub screw heavily.

## DOOR BRACKET ACCESSORY FOR DOORS WITH ALUMINIUM PROFILE



### DOOR BRACKET INSTALLATION

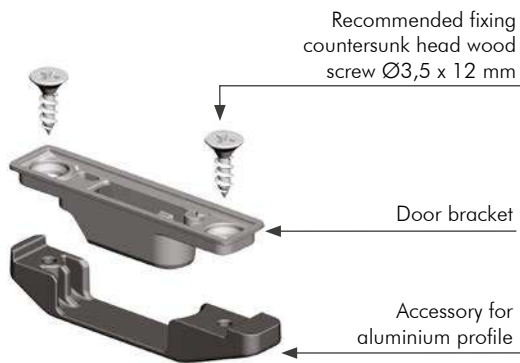

### DOOR SPECIFICATION

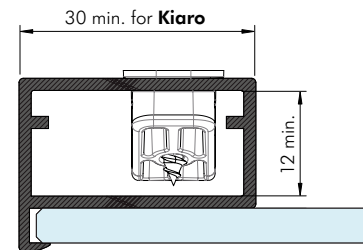

8 Join the door bracket with the accessory keeping the screws loose

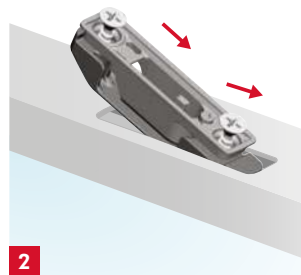
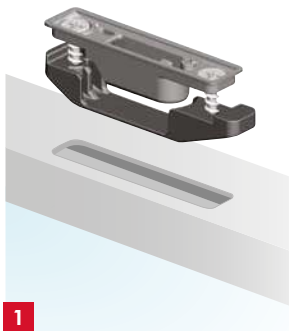

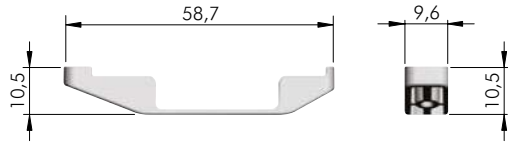

EP	= 1500 pcs.
<b>4630208000</b>	

## DRILLING PLAN FOR KIARO

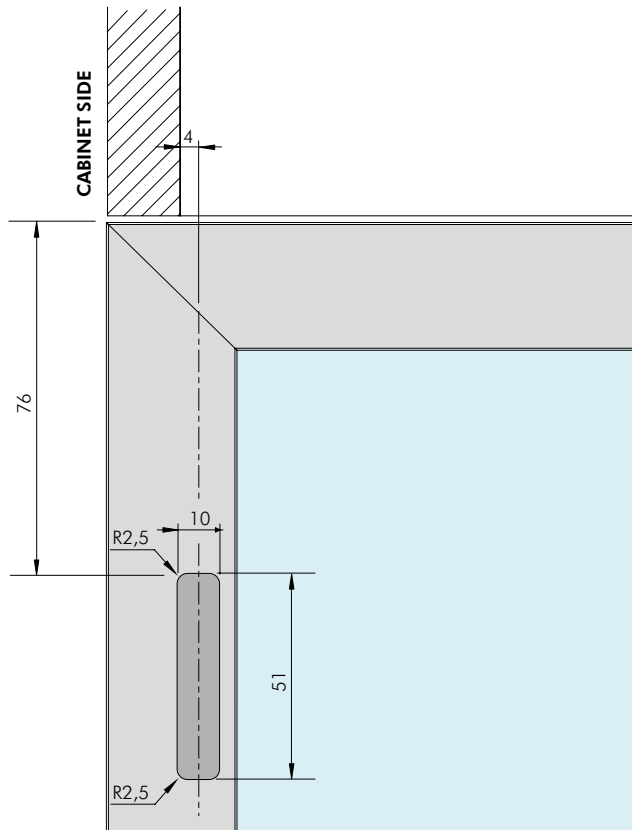

8

## FIXING ACCESSORY

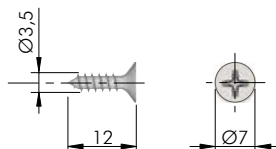

= Ø 3 mm	
= PZ2	
ST	= 10.000 pcs.
<b>60101380ZN</b>	



## KIARO FOX



### SIDE BRACKET FIXING



### MECHANISM FIXING

**STEP 1** - Stick on the back of the mechanism a double-sided tape. (NOT INCLUDED)

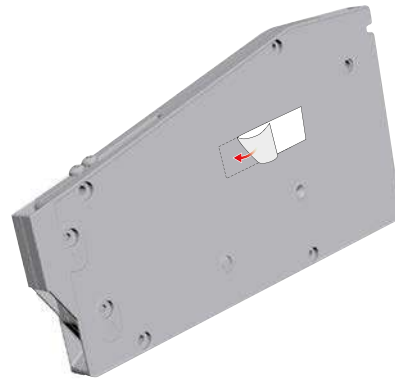

**STEP 2** - Fix the mechanism onto the cabinet by using the provided pins.

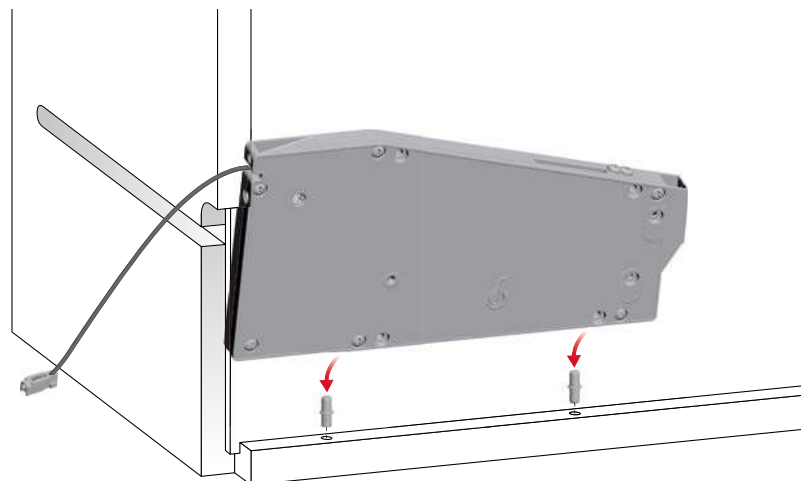



Insert the cable into the side bracket from the outside of the side panel.

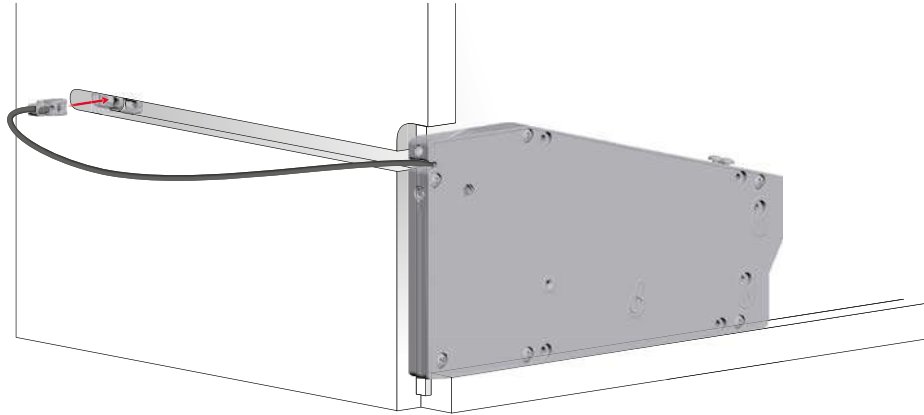

## WIRE INSERTING INTO THE SIDE BRACKET

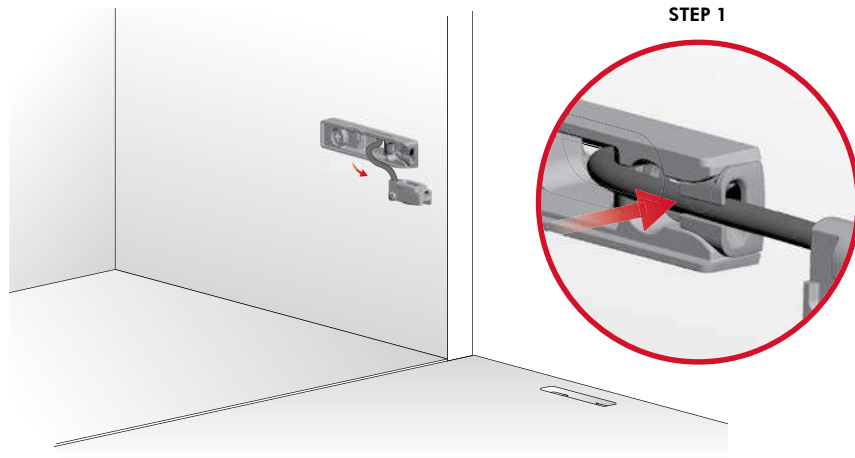

## WIRE CUTTING



**STEP 2**  
Stretch the wire and position it for cutting to size as shown on page 8.73.

## WIRE INSERTION ONTO THE DOOR BRACKET

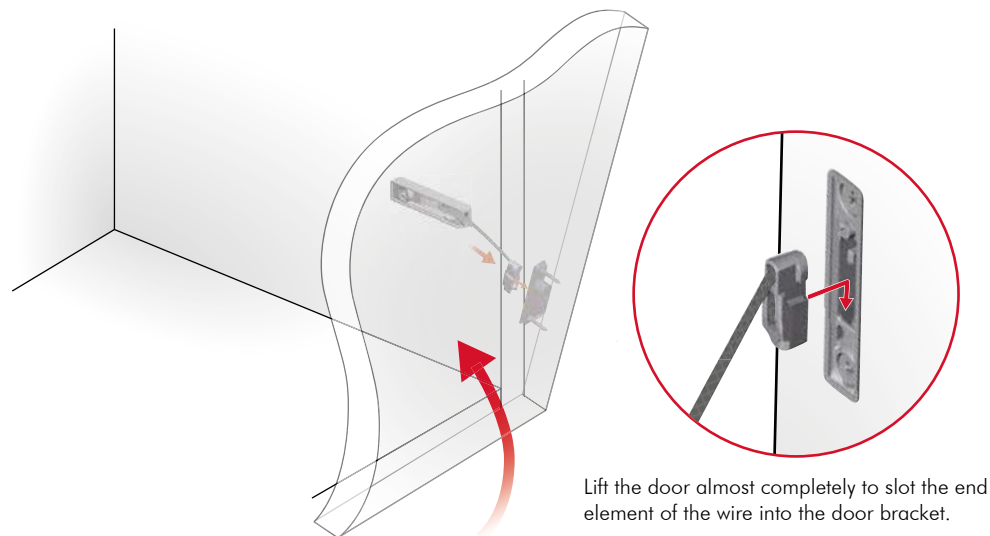

### STEP 1



### STEP 2



click

## COVER CAPS INSERTION

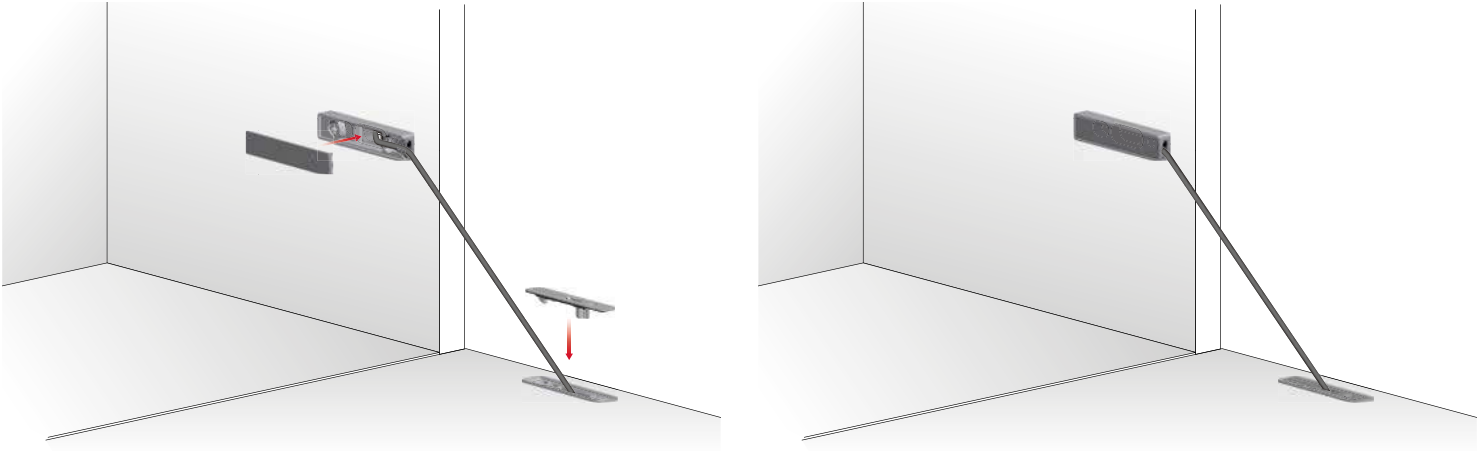

## INSTALLATION ENDING



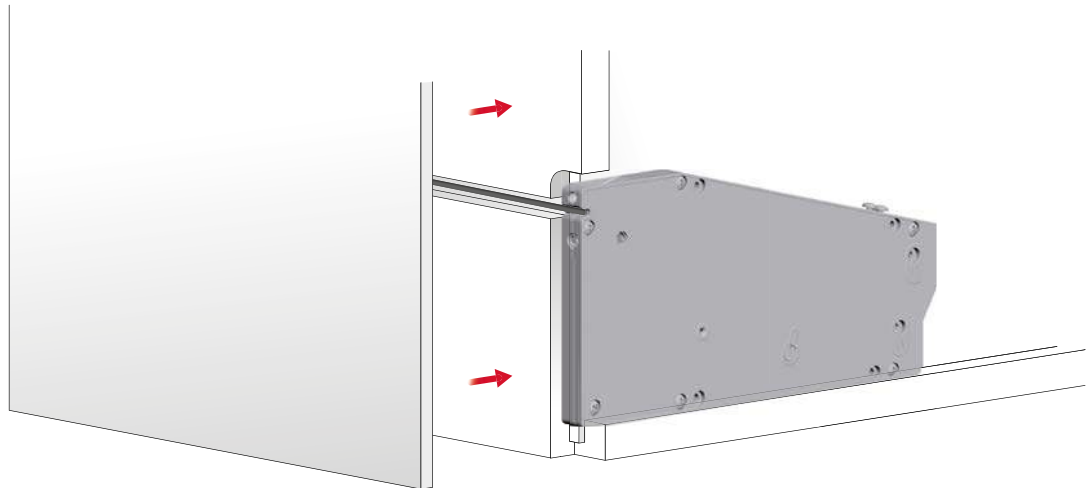

Mount the additional cover panel onto the side panel.

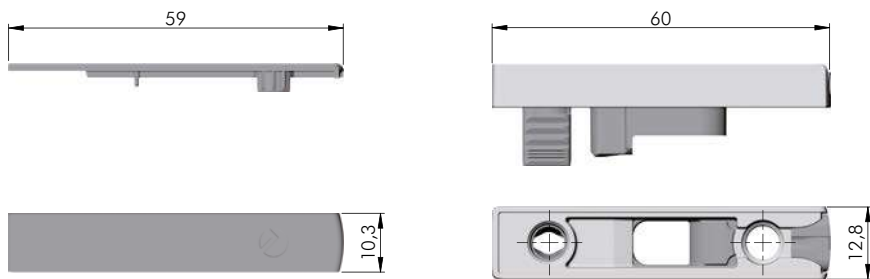

## KIARO FOX SET

8



	= Ø 5 mm
	 = 12 pcs.
	
<b>C010002577</b>	<b>YA</b>
<b>C010002578</b>	<b>YQ</b>

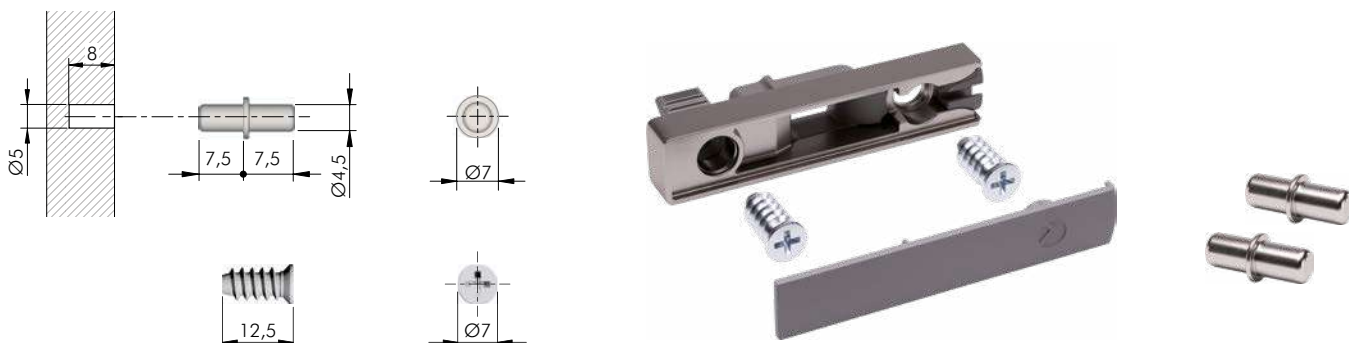



## KIARO FOX WITH KIMANA HINGE



### SIDE-PANEL DRILLING OPERATIONS

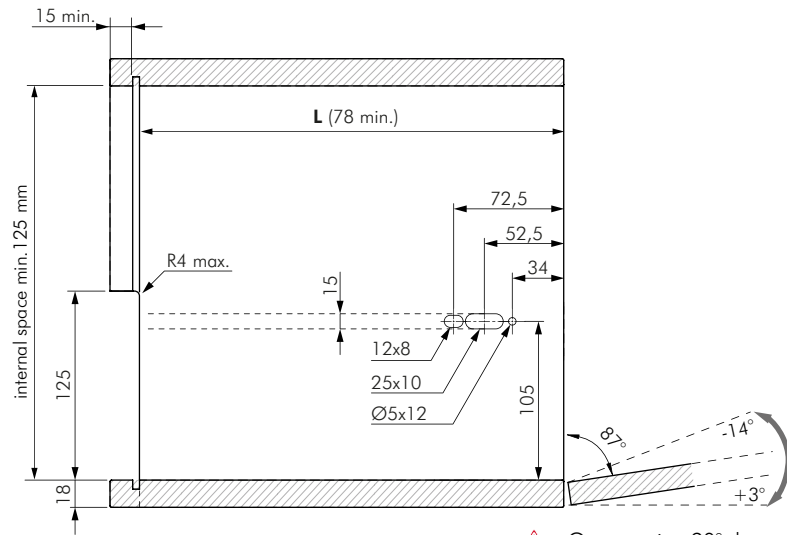
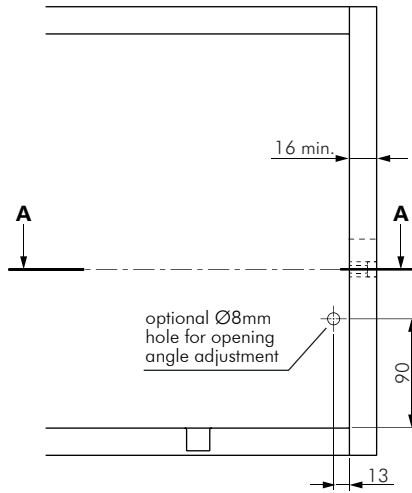

**!** Overcrossing 90° door opening angle, negatively affects the Kimana hinges.

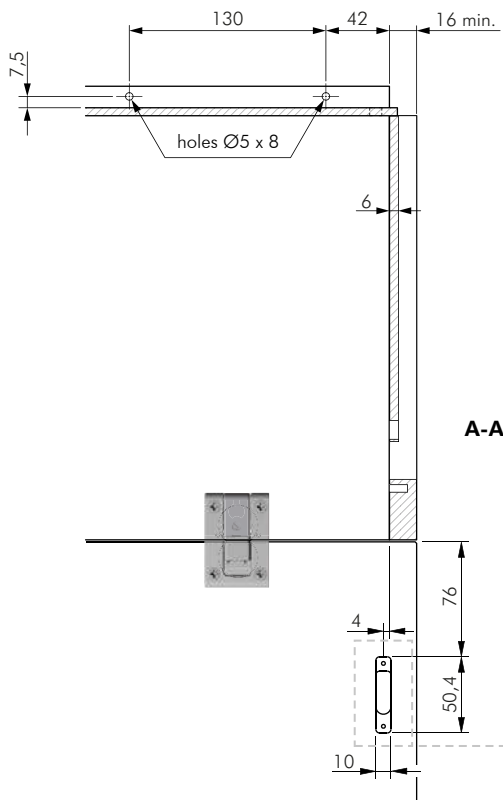

### DOOR PANEL DRILLING OPERATIONS

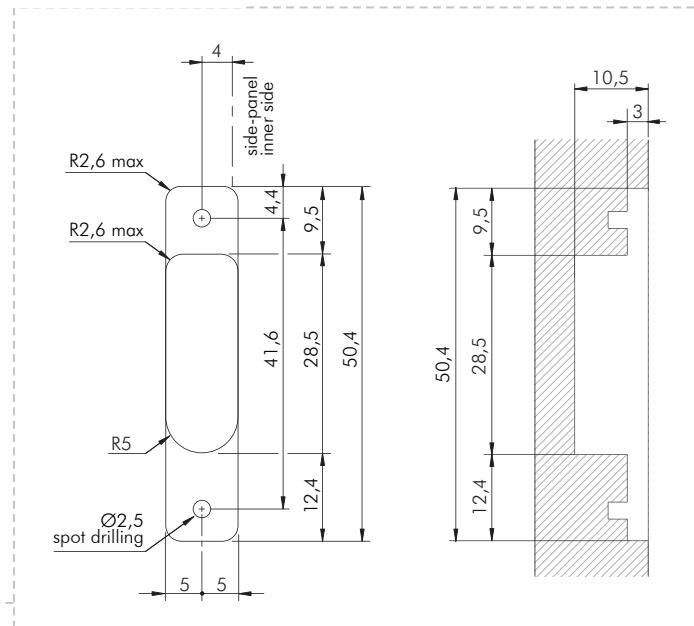

## BACK-PANEL DRILLING OPERATIONS

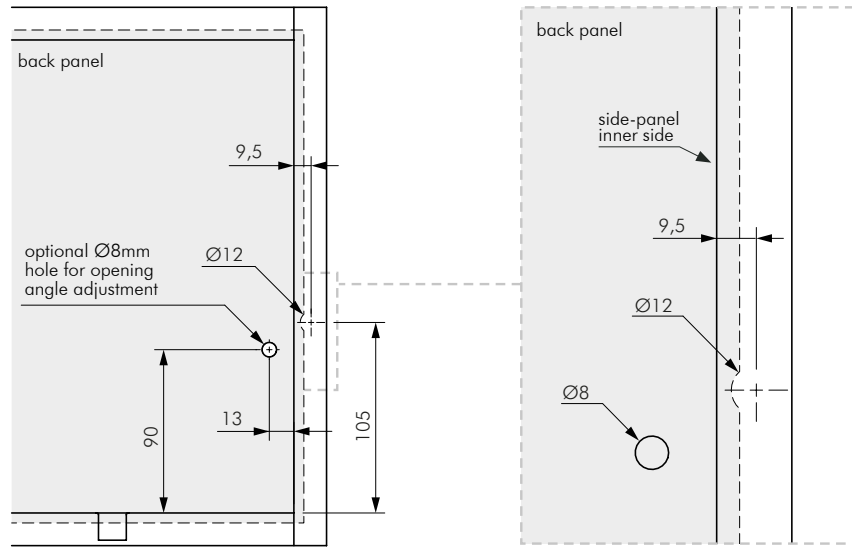

In case of door without handles it is recommended to use **K Push Tech with buffer**.

## KIARO FOX WITH STANDARD UNSPRUNG HINGES

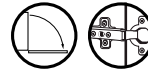

In case the hinges to be installed are not KIMANA hinges, please contact our technical department to receive the correct drilling plan. It is necessary to indicate all the values requested in the following diagram:

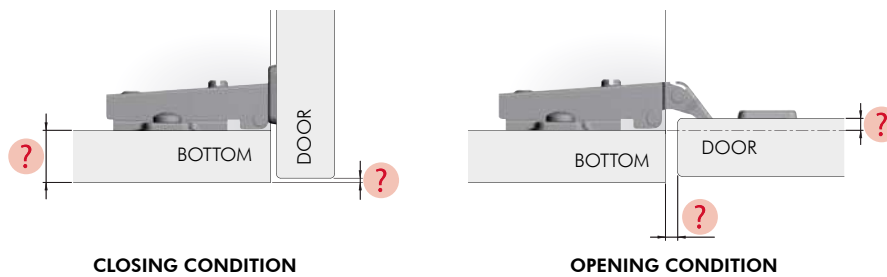

8





## KIARO SKIN



### UNHANDED MECHANISM

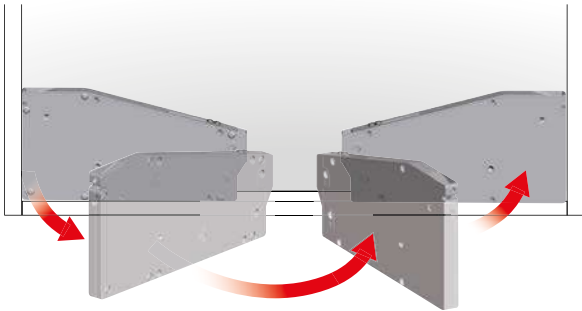

### MECHANISM INSTALLATION

#### STEP 1

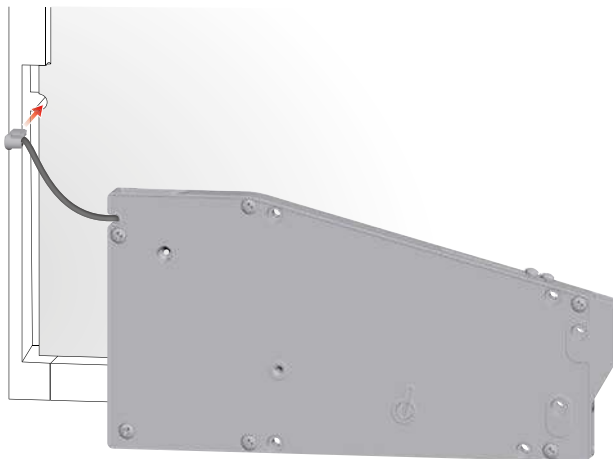

#### STEP 2

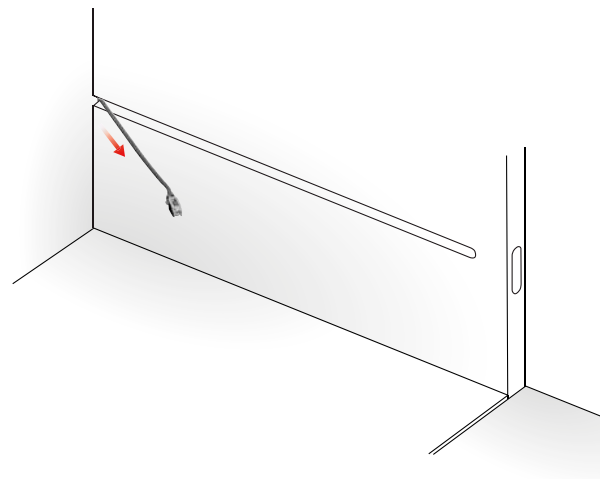

## MECHANISM FIXING

### STEP 1

Stick on the back of the mechanism a double-sided tape. (NOT INCLUDED)



### STEP 2

Fix the mechanism onto the cabinet by using the provided pins.

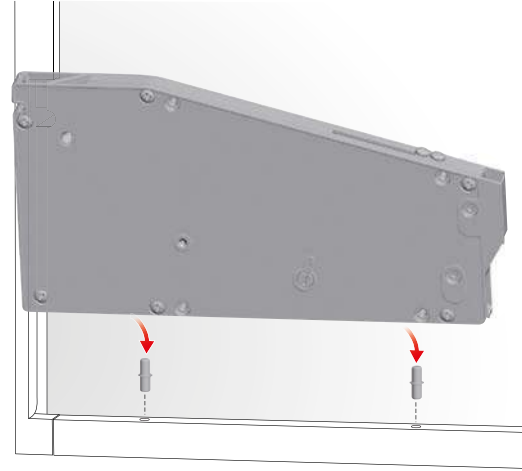

## WIRE CUTTING

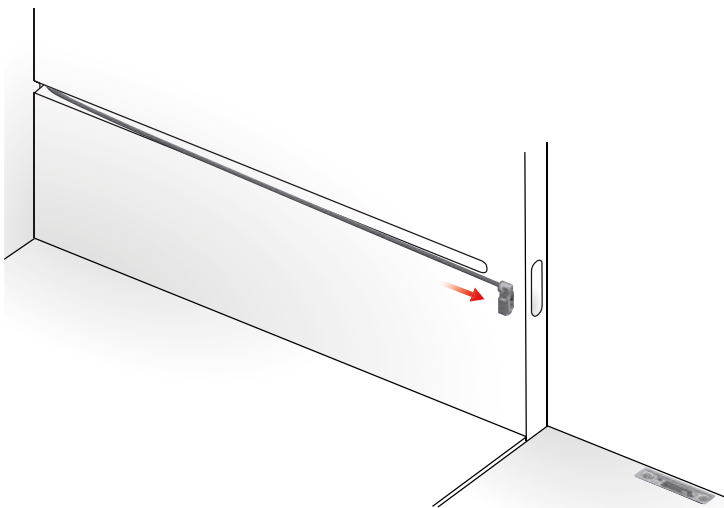

## INSTRUCTIONS FOR WIRE CUTTING

### INSERTION OF THE WIRE INTO THE END PART AND LOCKING WITH M3 GRUB SCREW

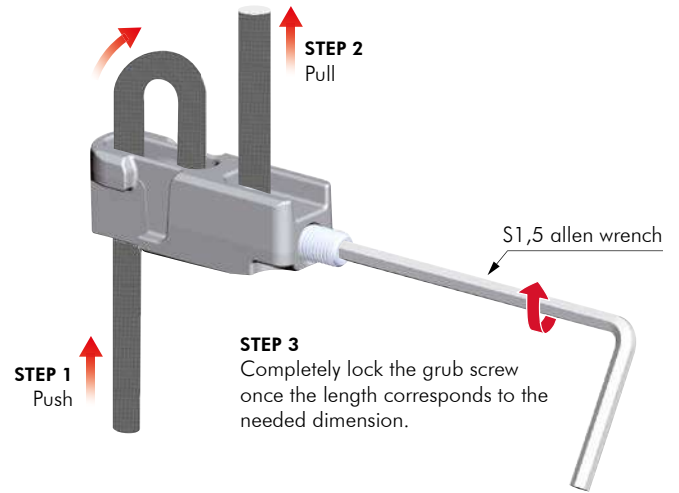

8

## WIRE CUTTING WITH UNMOUNTED MECHANISM

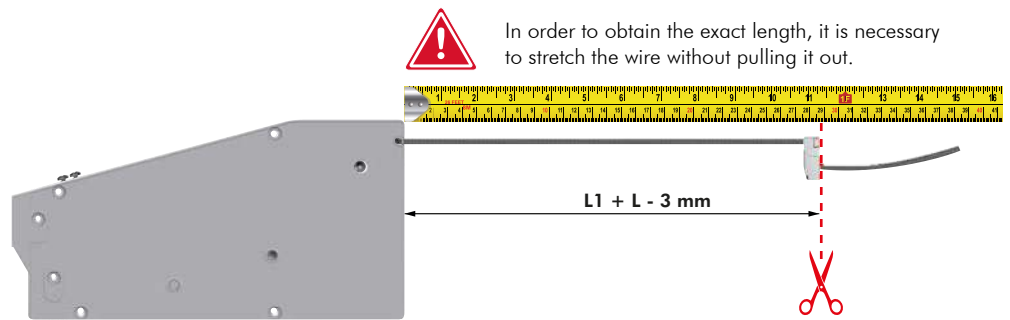
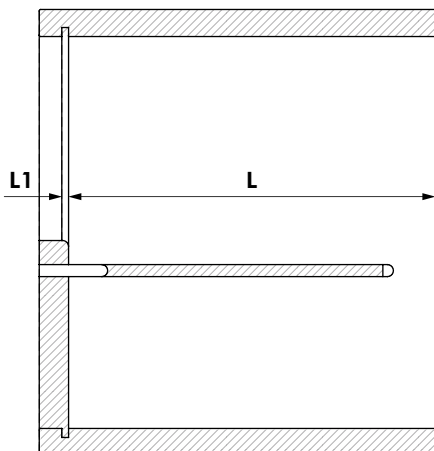

**VERY IMPORTANT:**  
Before cutting, it is necessary to lock the grub screw heavily.



## WIRE CUTTING WITH MOUNTED MECHANISM

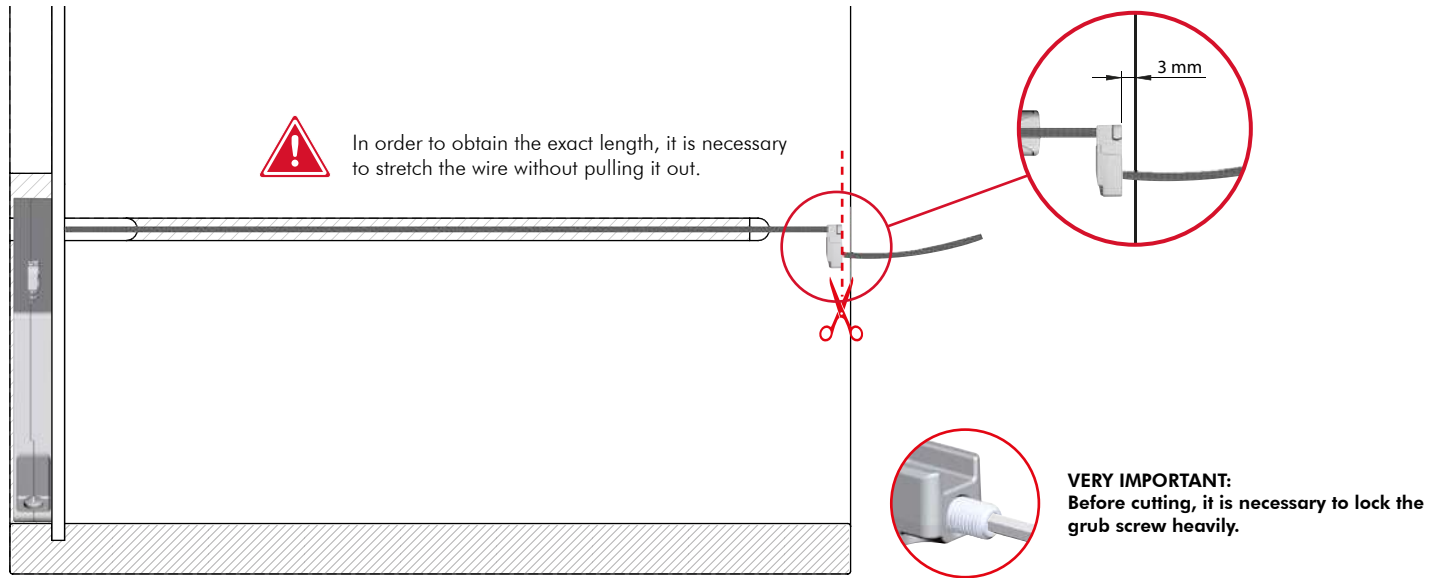

## WIRE INSERTION ON THE SIDE MILLING

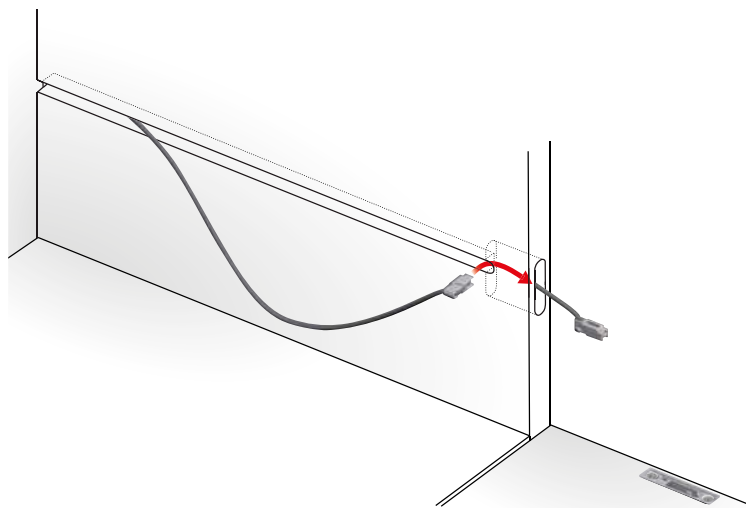

## POSITIONING OF THE FRONTAL HOUSING INTO THE FRONT MILLING OF THE CABINET SIDE

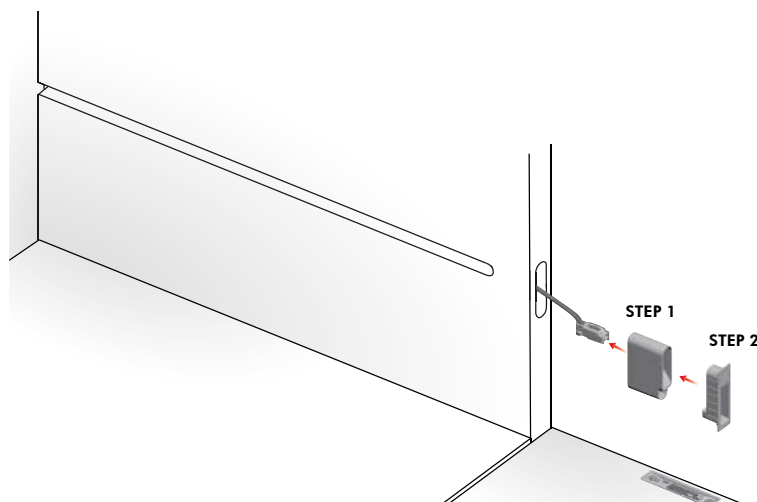

**!** Before positioning the frontal housing into the front milling of the cabinet side, it is recommended to verify its right direction.

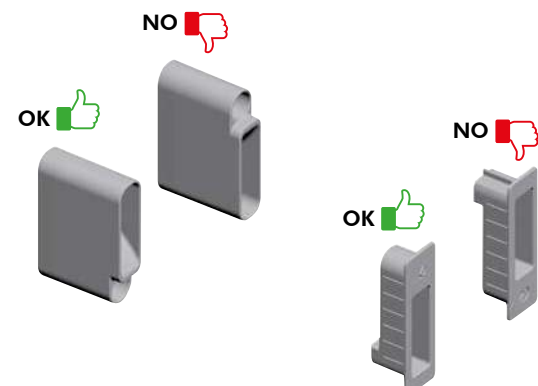



# OPENING SYSTEMS FOR LIFT UP AND DROP DOWN DOORS

## STEP 1

Insert partially the frontal housing.

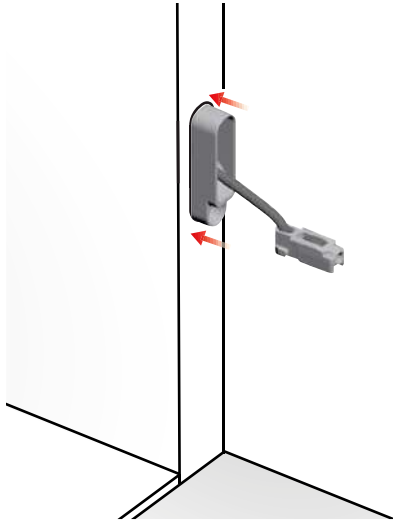

## STEP 2

Complete the insertion by using the cover of the frontal housing.

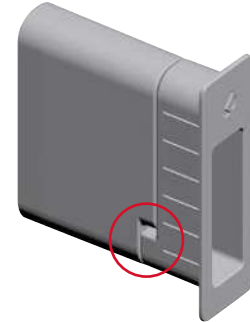
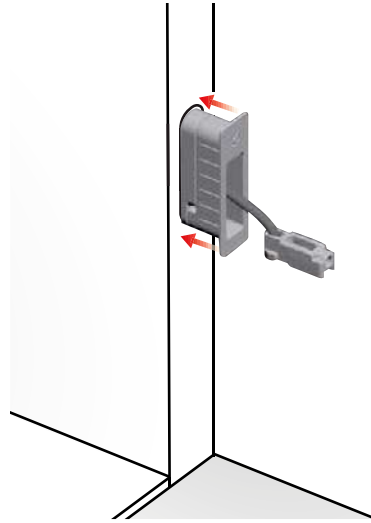

The recess of the two pieces makes the insertion into the front milling of the cabinet side easier.

## WIRE INSERTION ONTO THE DOOR BRACKET

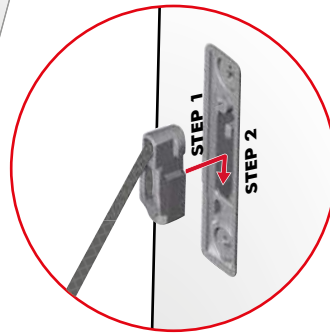
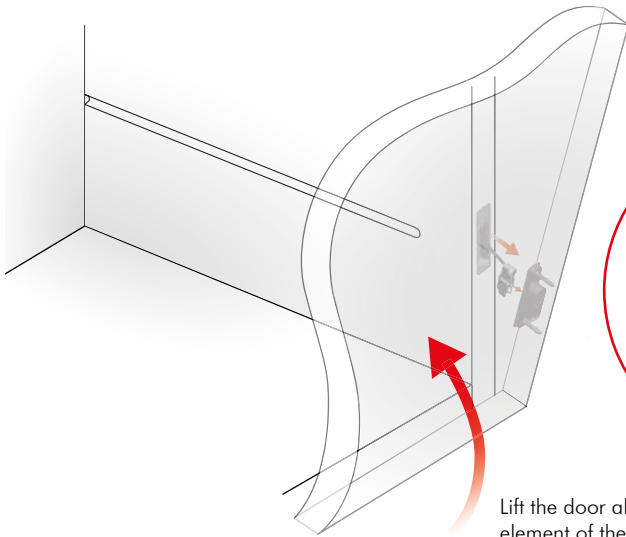

Lift the door almost completely to slot the end element of the wire into the door bracket.

## STEP 1



## STEP 2



click



8

## COVER CAPS INSERTION

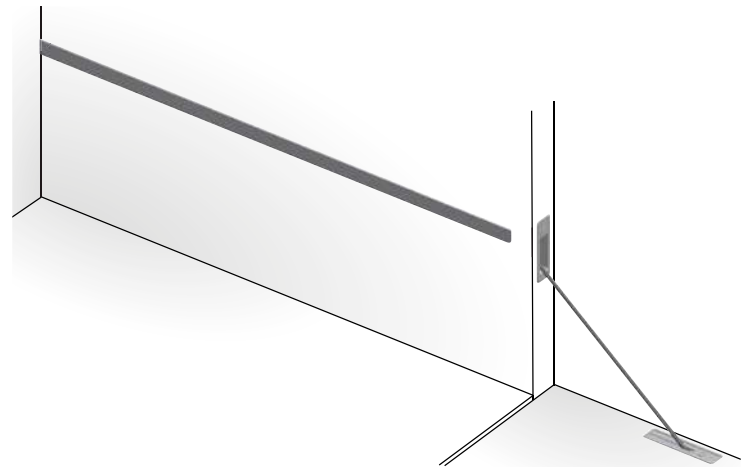
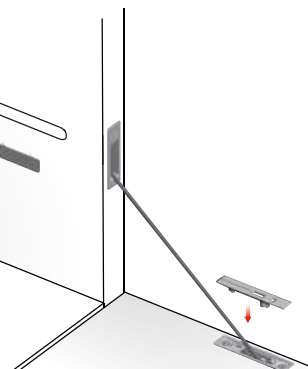
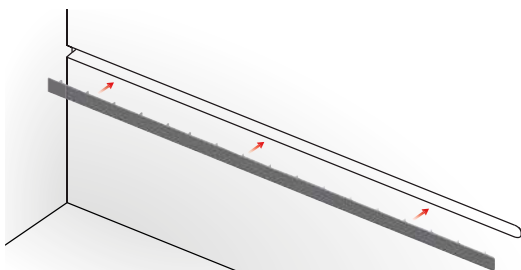

It is recommended to position the cover against the backside panel for a correct insertion.



## RULES FOR SIDE COVER CUT TO SIZE

### SIDE COVER CUT TO SIZE

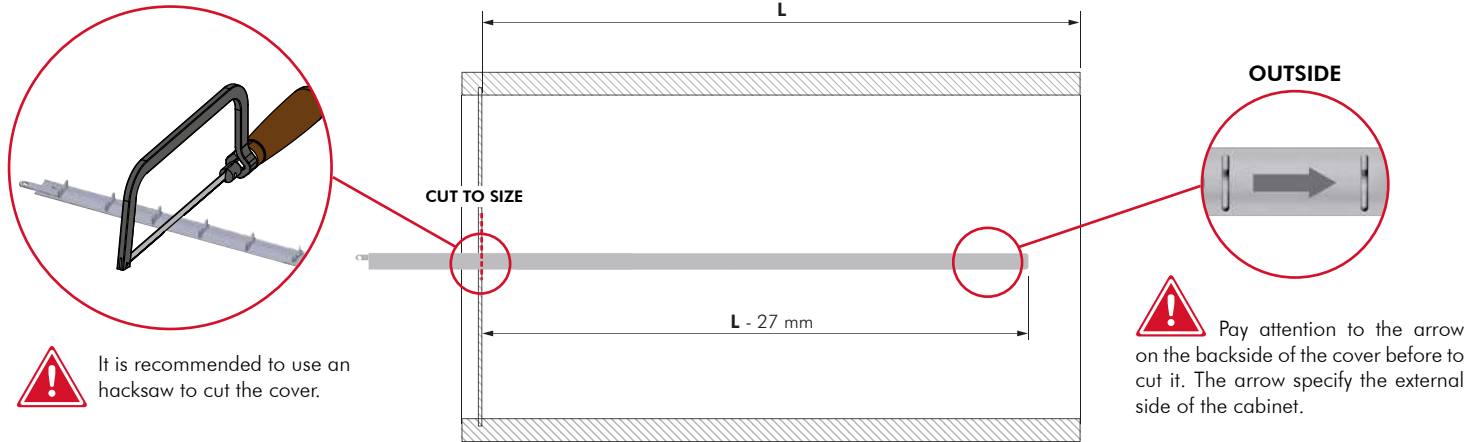

### SIDE COVER CUT TO SIZE FOR CABINET INTERNAL SPACE (L) > 527 mm

It is necessary to order 2 covers.

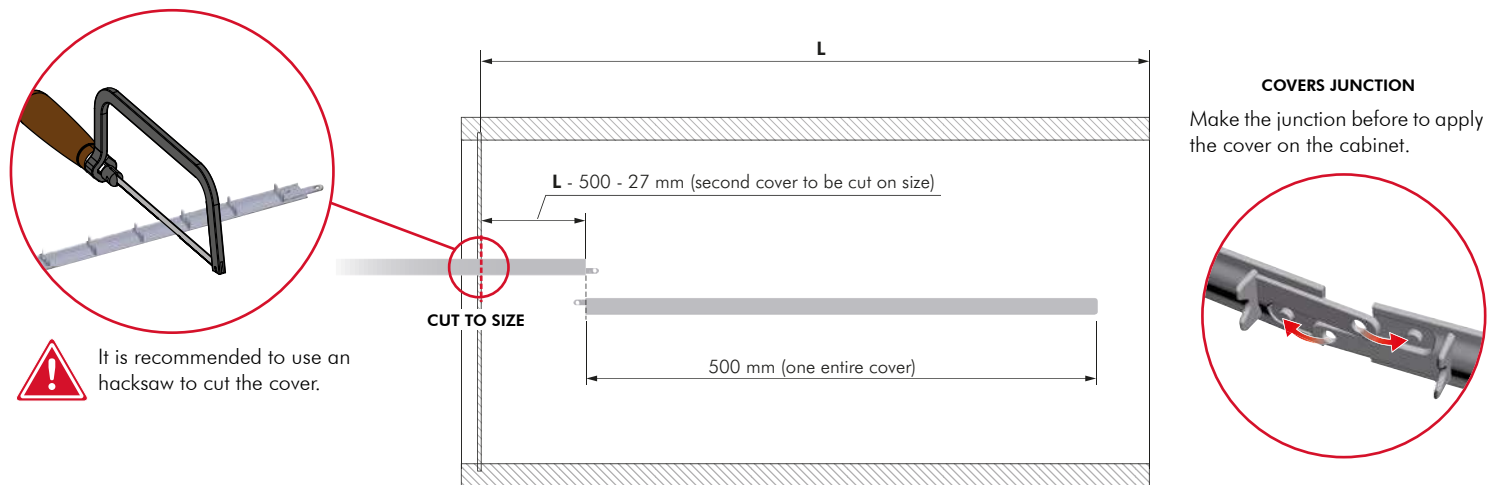



# OPENING SYSTEMS FOR LIFT UP AND DROP DOWN DOORS

## KIARO SKIN SIDE SUPPORTS

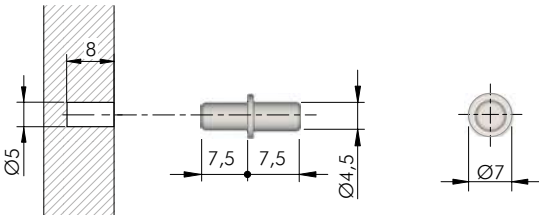
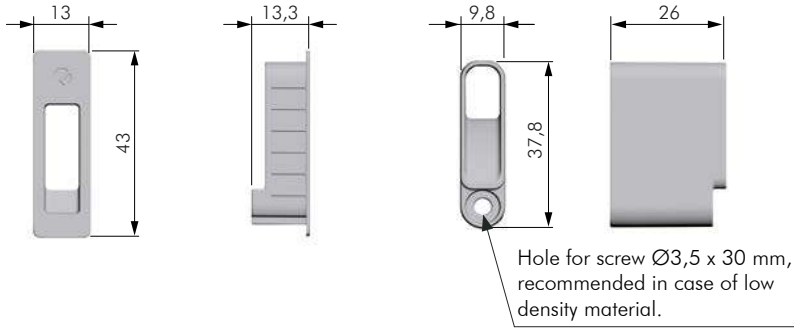

## KIARO SKIN SIDE COVER

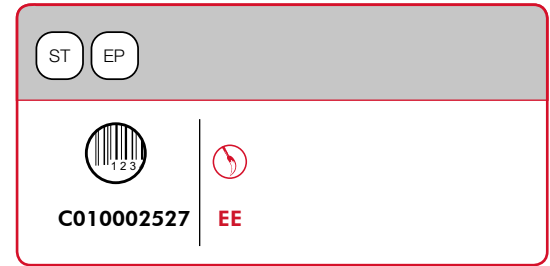
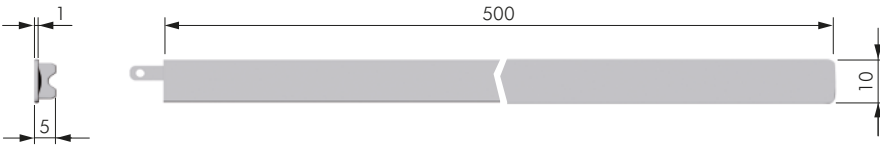

NOTE: the set includes all the components shown in the picture.





## KIARO SKIN WITH KIMANA HINGE



### SIDE-PANEL DRILLING OPERATIONS

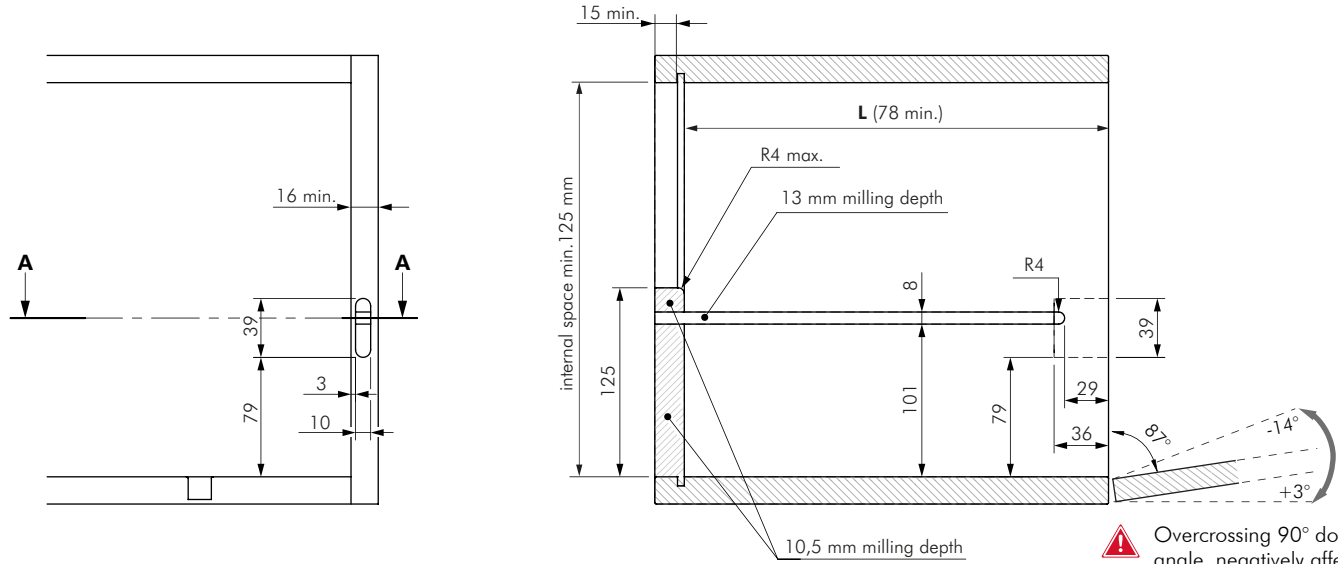

**⚠** Overcrossing 90° door opening angle, negatively affects the Kimana hinges.

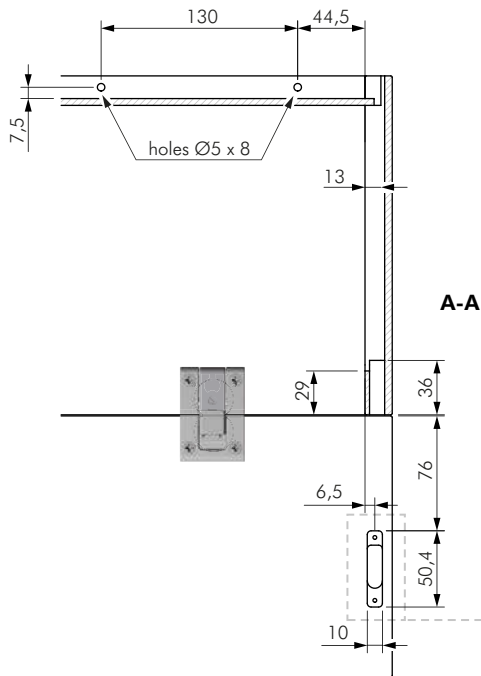

### DOOR PANEL DRILLING OPERATIONS

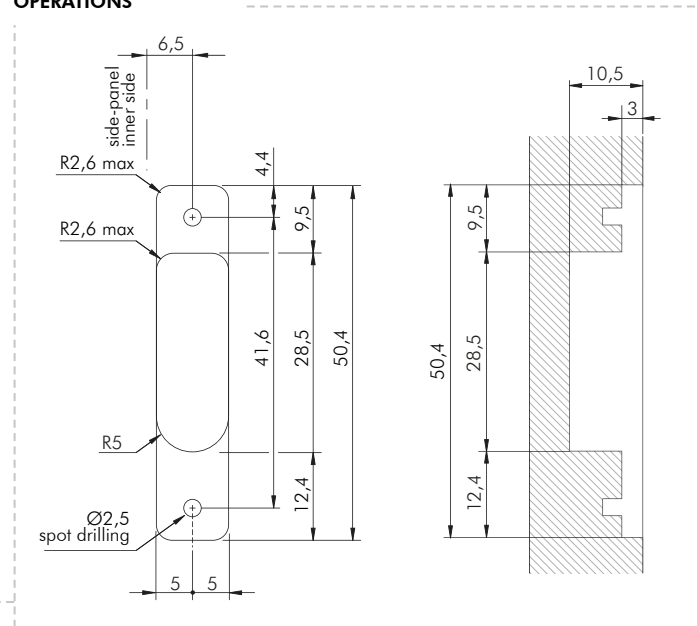

## BACK-PANEL DRILLING OPERATIONS

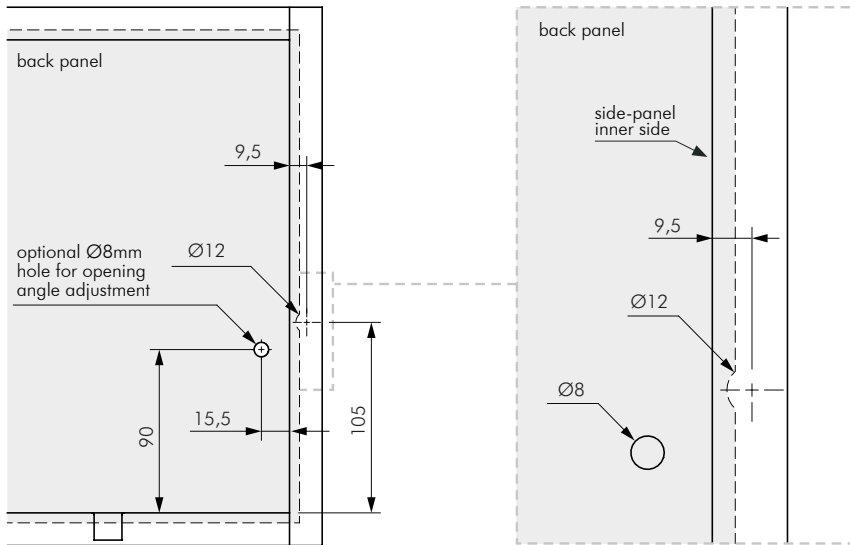

In case of door without handles it is recommended to use **K Push Tech with buffer**.

## KIARO SKIN WITH STANDARD UNSPRUNG HINGES

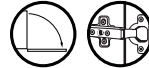

In case the hinges to be installed are not KIMANA hinges, please contact our technical department to receive the correct drilling plan. It is necessary to indicate all the values requested in the following diagram:

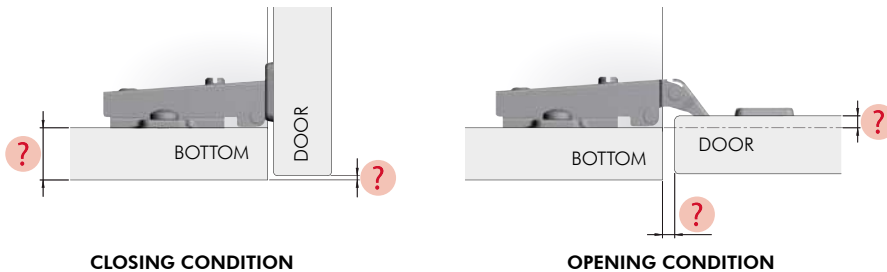





## KIARO DECK - Alternative applications of Kiara

### KIARO DECK - Version 1



**NOTE:**

The following installation and technical drawings refer only to the cover panel for Kiara Deck application. **For installation and drilling plans of Kiara please refer to the dedicated brochure or catalogue section.**

#### INTERNAL PANEL INSTALLATION

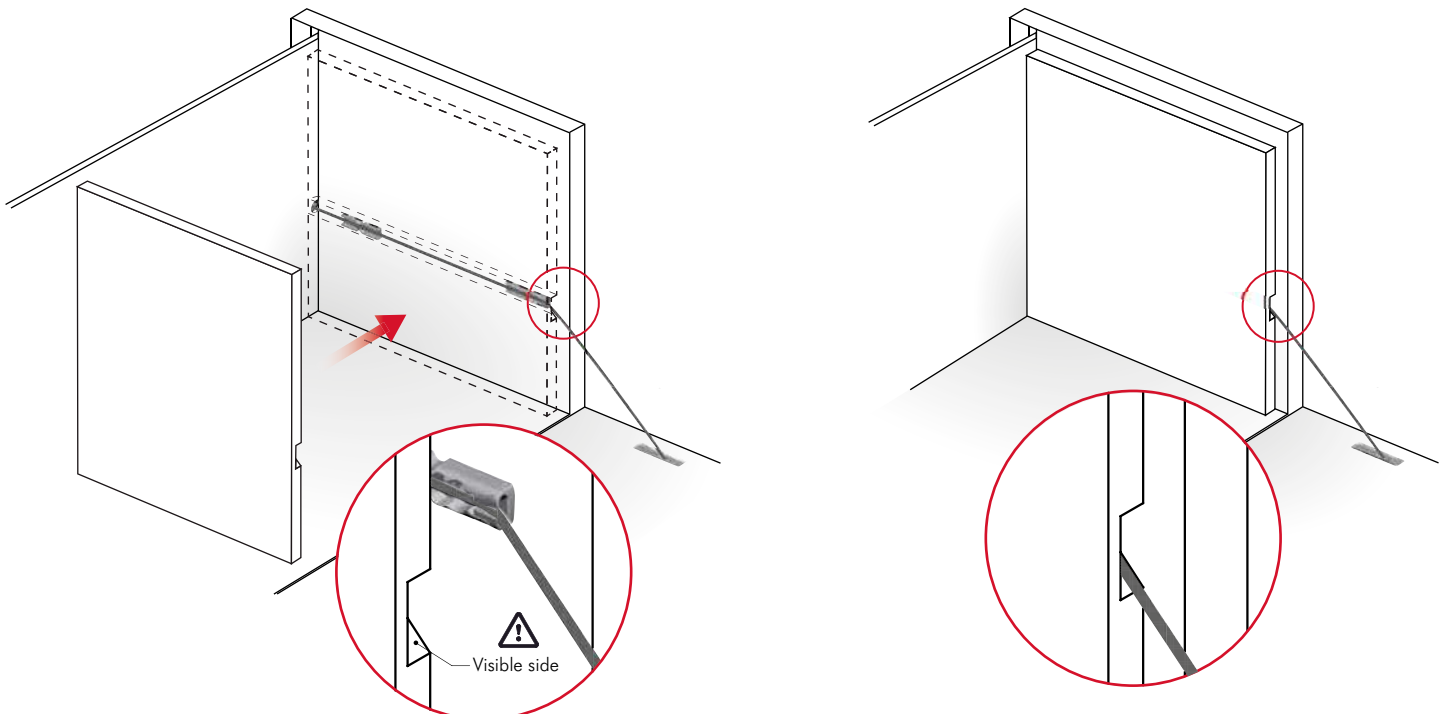

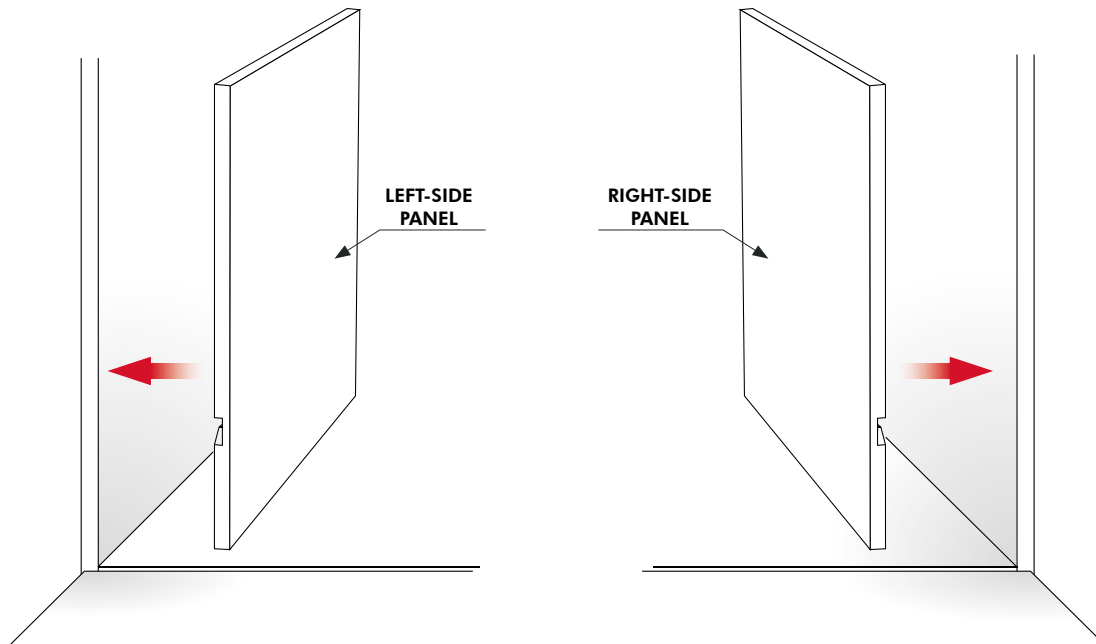

## INTERNAL PANEL DIMENSIONS AND MILLING OPERATION

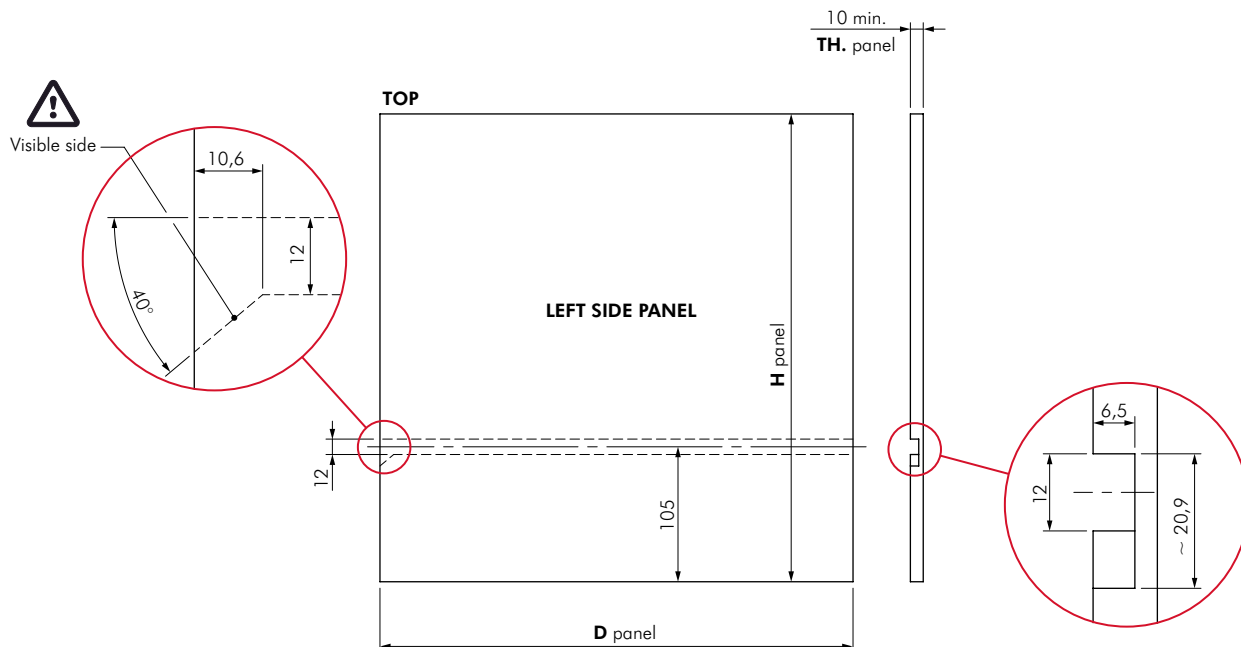
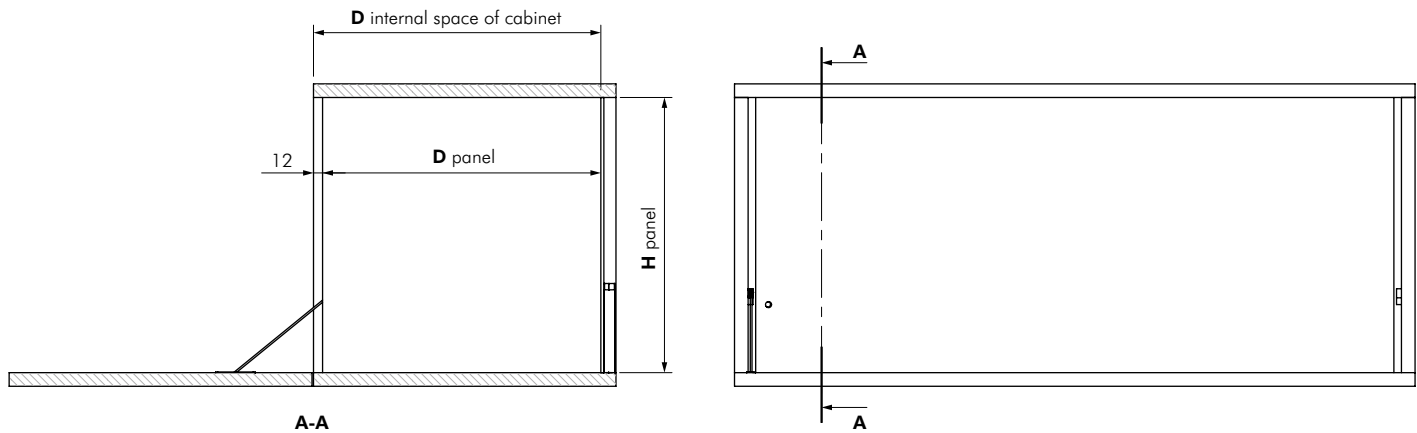



## KIARO DECK - Version 2



### NOTE:

The following installation and technical drawings refer only to the cover panel for Kiaro Deck application. **For installation and drilling plans of Kiaro please refer to the dedicated brochure or catalogue section.**

### INTERNAL PANEL INSTALLATION

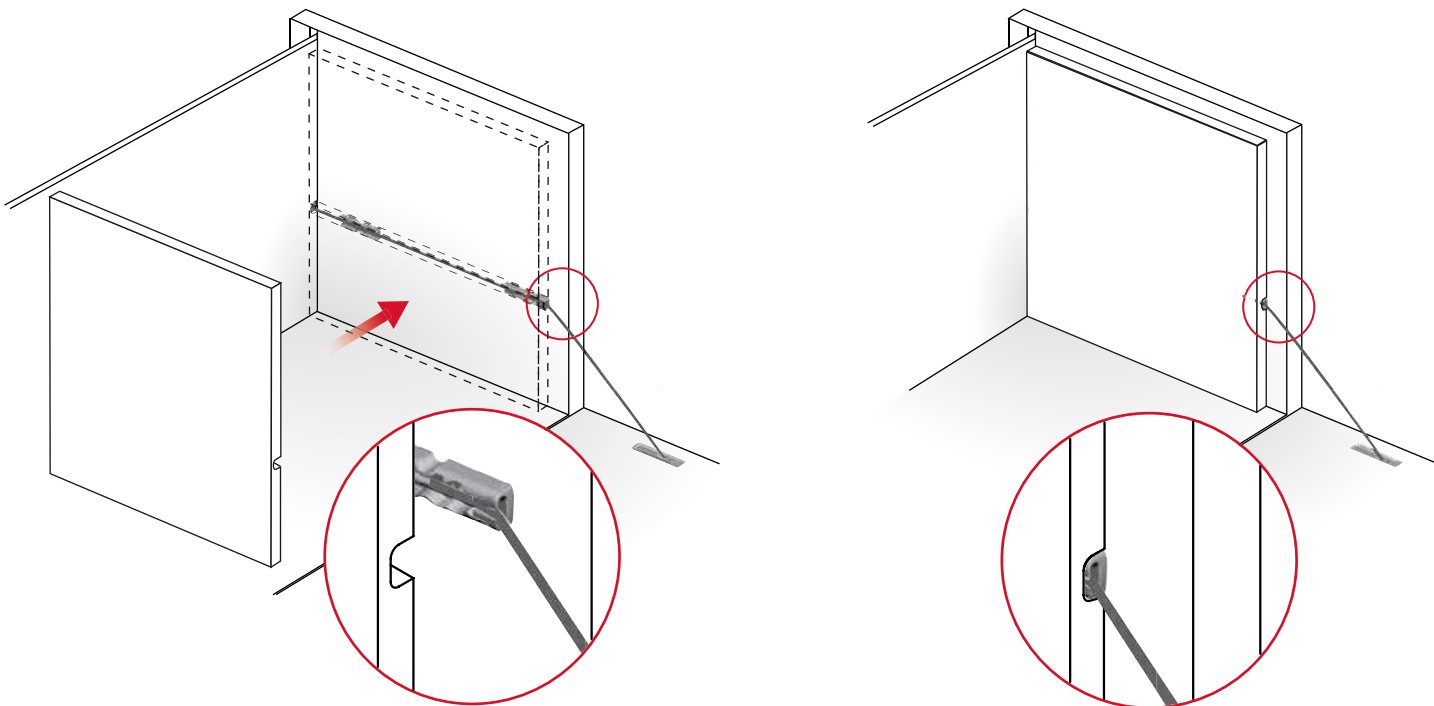

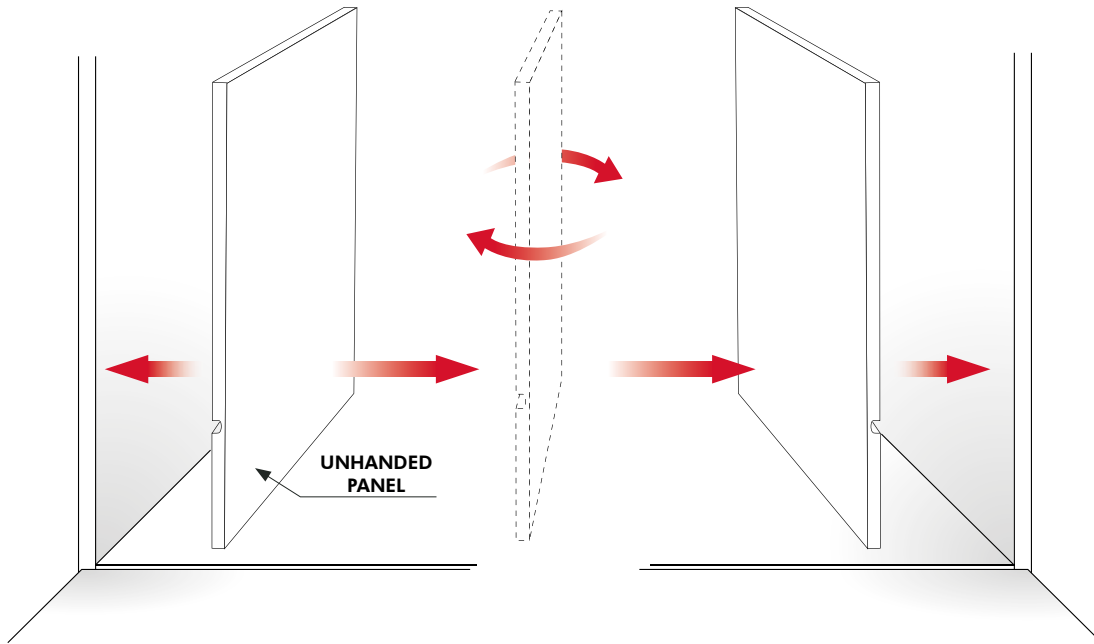

## INTERNAL PANEL DIMENSIONS AND MILLING OPERATION

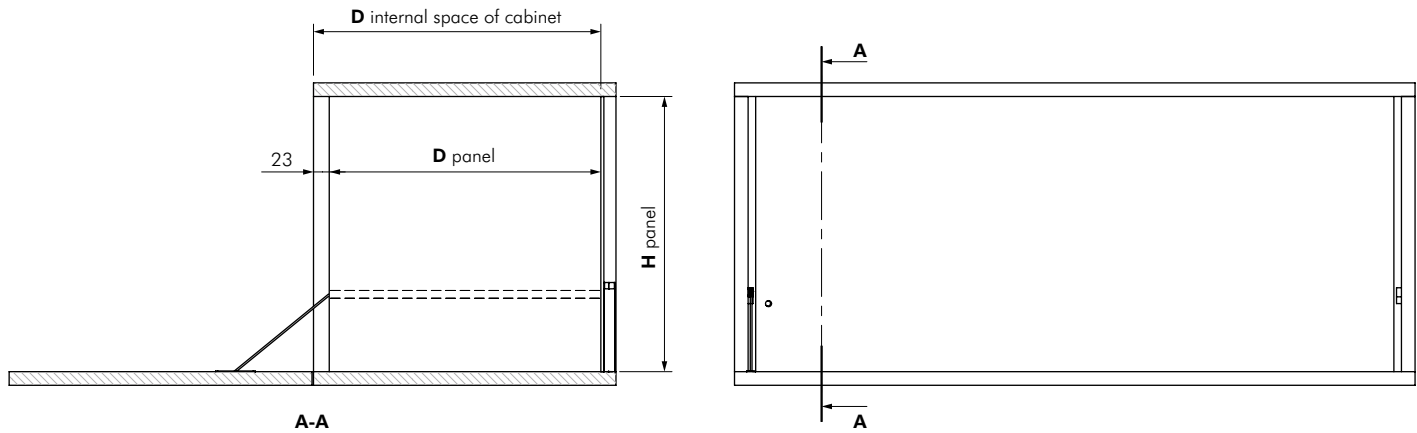

8

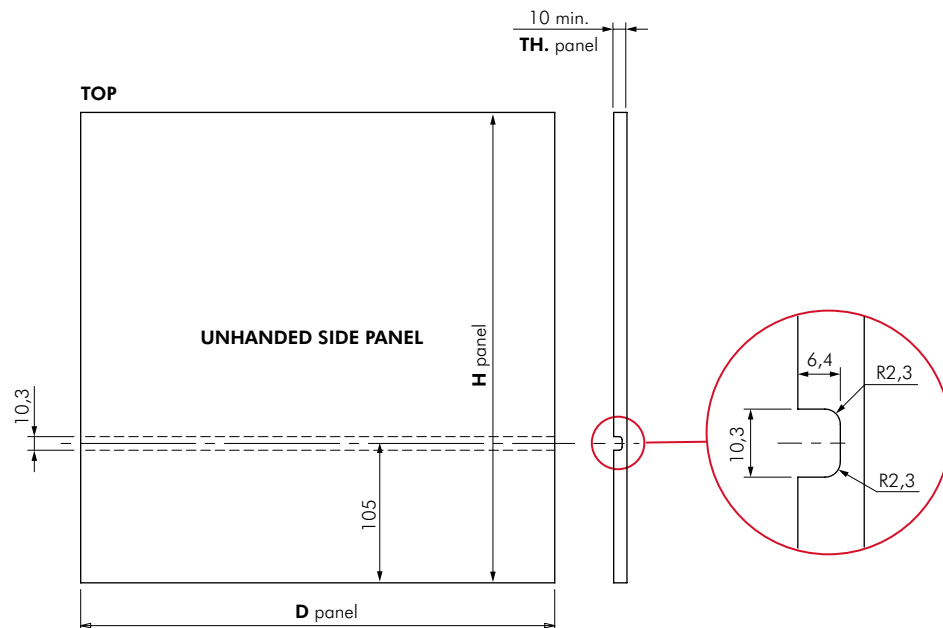



## KIARO EASY



### AVAILABLE FINISHES

Anthracite (EE)

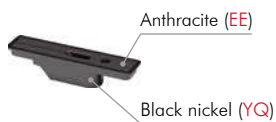

Brown 8019 (LD)

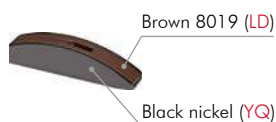
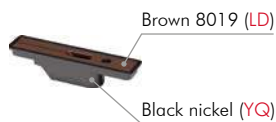

Grey 9007 (EW)

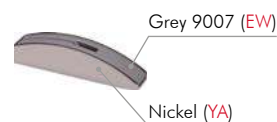

White (AB)

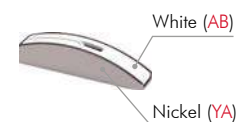



## KIARO EASY SINGLE INSTALLATION

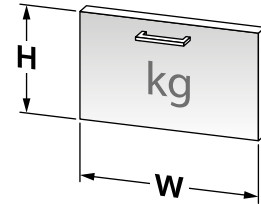
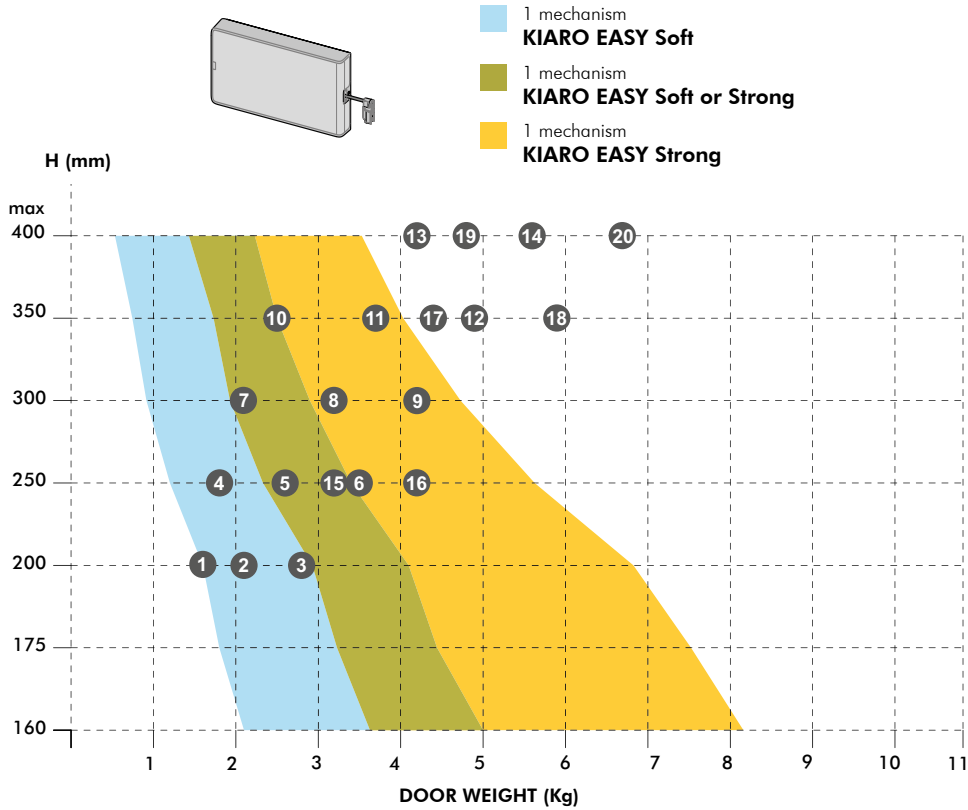

Door weight including the possible handle.

		H	W	Weight
		mm	mm	theoretical
1	Chipboard door thk 18mm	200	600	1,6 kg
2	Chipboard door thk 18mm	200	900	2,1 kg
3	Chipboard door thk 18mm	200	1200	2,8 kg
4	Chipboard door thk 18mm	250	600	1,8 kg
5	Chipboard door thk 18mm	250	900	2,6 kg
6	Chipboard door thk 18mm	250	1200	3,5 kg
7	Chipboard door thk 18mm	300	600	2,1 kg
8	Chipboard door thk 18mm	300	900	3,2 kg
9	Chipboard door thk 18mm	300	1200	4,2 kg
10	Chipboard door thk 18mm	350	600	2,5 kg
11	Chipboard door thk 18mm	350	900	3,7 kg
12	Chipboard door thk 18mm	350	1200	4,9 kg
13	Chipboard door thk 18mm	400	900	4,2 kg
14	Chipboard door thk 18mm	400	1200	5,6 kg
15	MDF door thk 18mm	250	900	3,2 kg
16	MDF door thk 18mm	250	1200	4,2 kg
17	MDF door thk 18mm	350	900	4,4 kg
18	MDF door thk 18mm	350	1200	5,9 kg
19	MDF door thk 18mm	400	900	4,8 kg
20	MDF door thk 18mm	400	1200	6,7 kg

Weight considering: Chipboard 650 Kg/m<sup>3</sup> and MDF 780 Kg/m<sup>3</sup>.

## KIARO EASY DOUBLE INSTALLATION

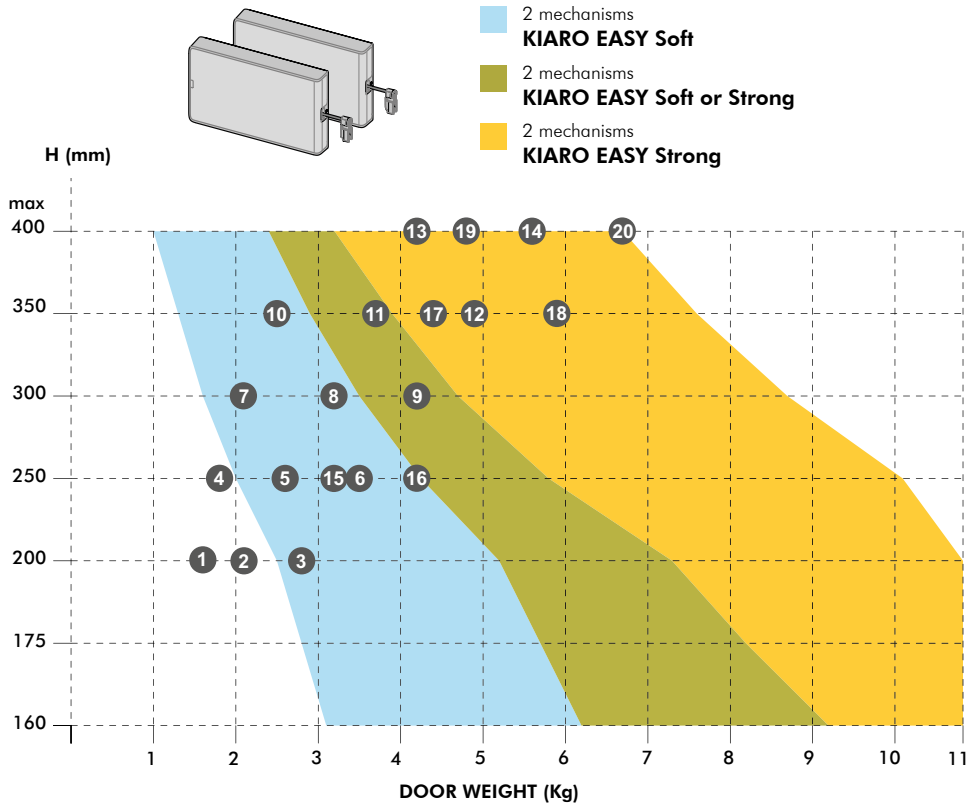

8

These are experimental results to be checked by the customer.

In accordance with the actual European regulation, we suggest where possible to use two KIARO EASY mechanisms for each door. Our technical department is at your disposal to analyze further cases out of this chart.



## UNHANDED MECHANISM

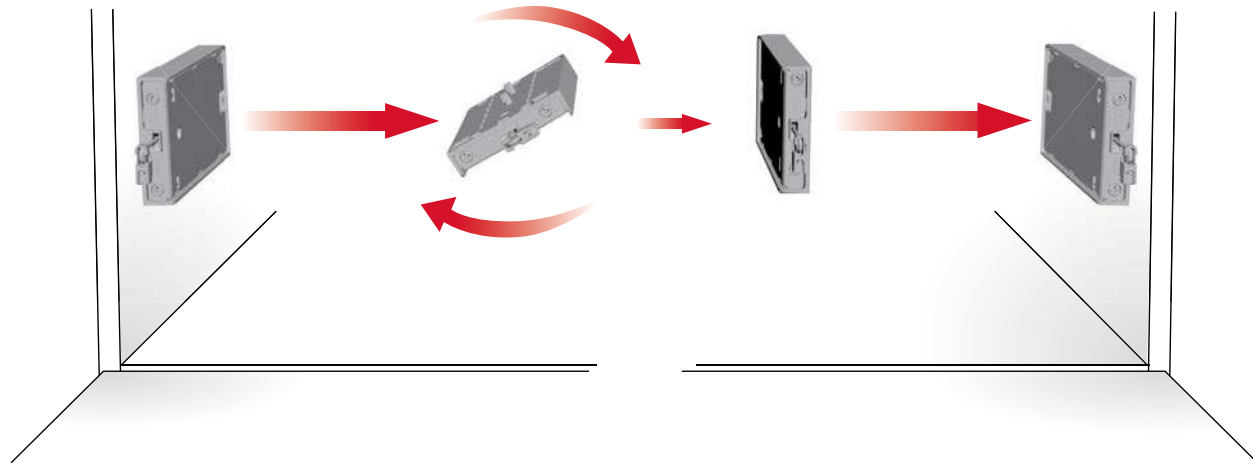

## MECHANISM AND DOOR BRACKET INSTALLATION

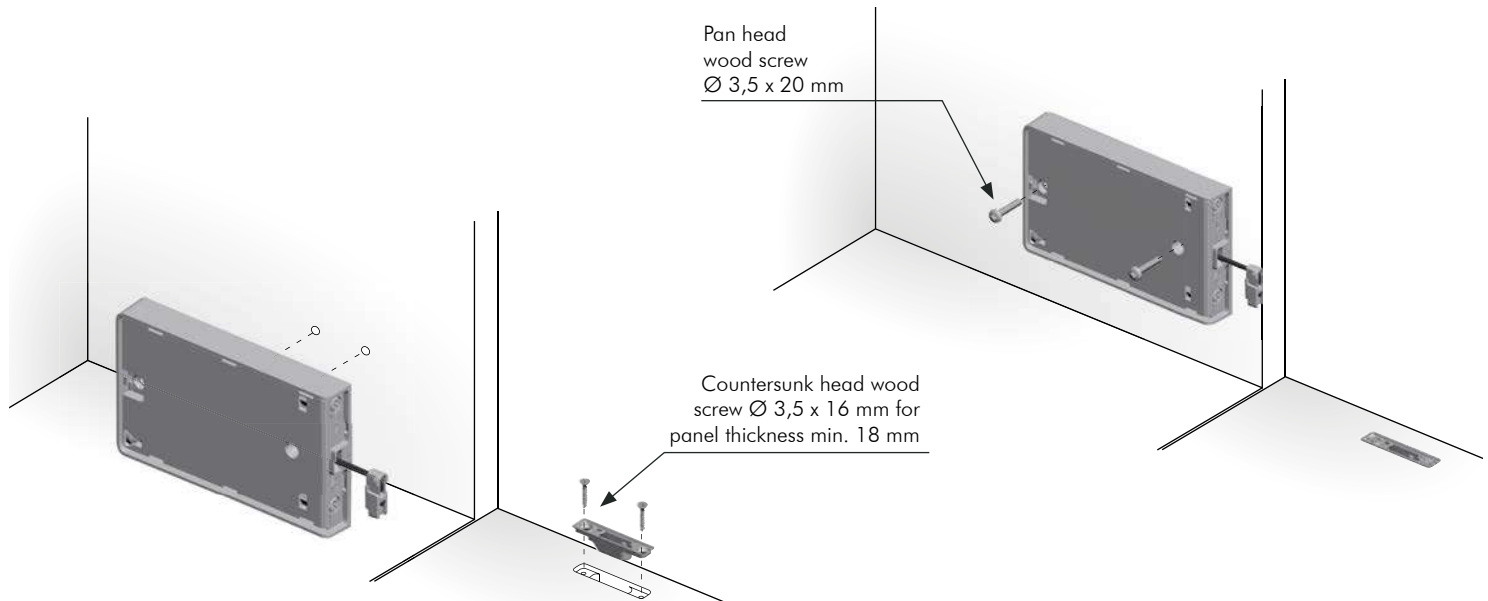

8

## WIRE INSERTION ONTO THE DOOR BRACKET

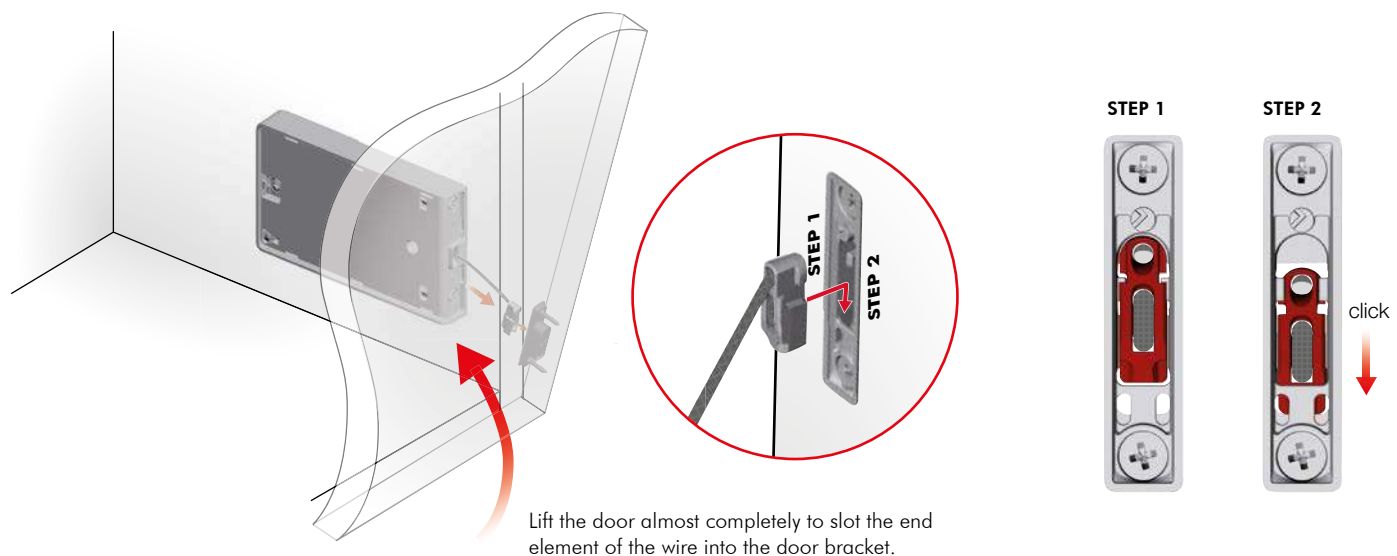

## DOOR BRACKET COVER CAP INSERTION

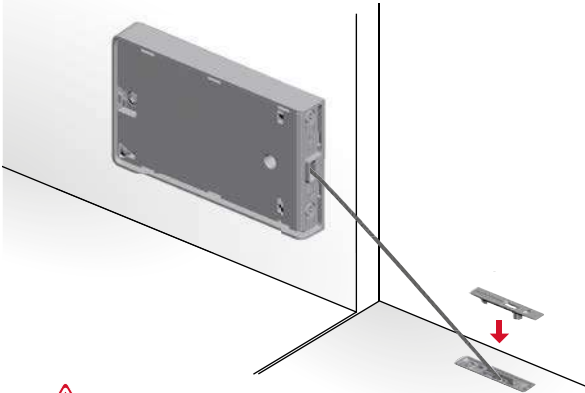

Place the cover cap on the door bracket before lifting the door.

## OPENING ANGLE ADJUSTMENT

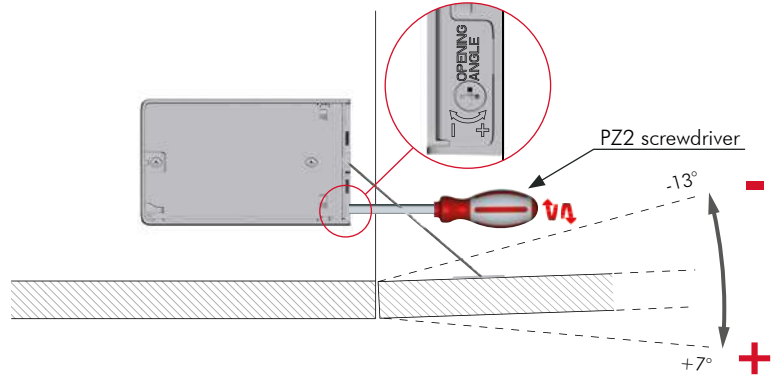

The adjustment of door opening angle must be carried out before the power adjustment.

## POWER ADJUSTMENT

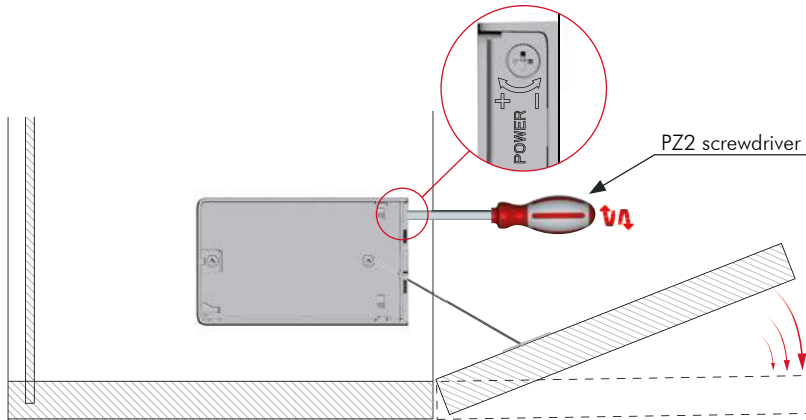

### Power +

The slowing phase of door opening is anticipated.

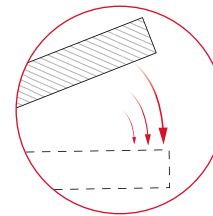

### Power -

The slowing phase of door opening is delayed.

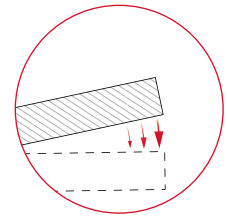

## MECHANISM COVER INSERTION

### STEP 1

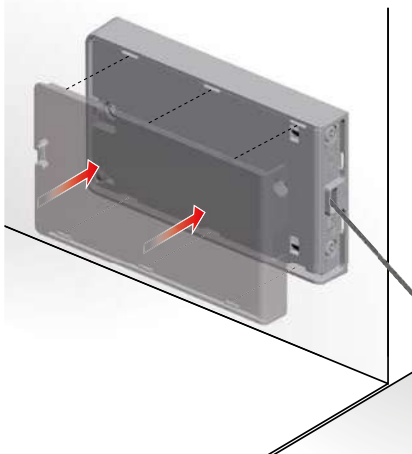

### STEP 2

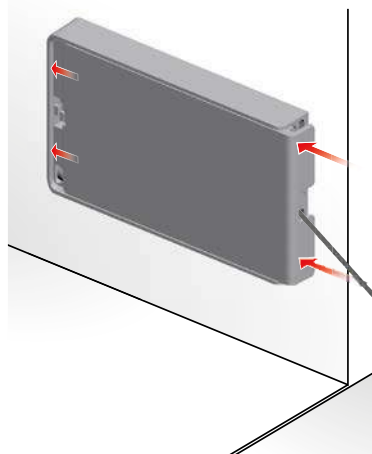

## MECHANISM COVER REMOVAL

Use a blade screwdriver to unlock the cover and proceed with showed removal steps.

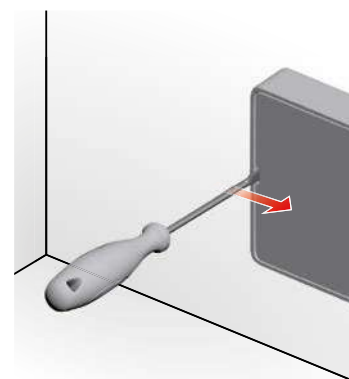

### REMOVAL STEP 1

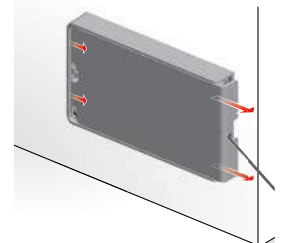

### REMOVAL STEP 2

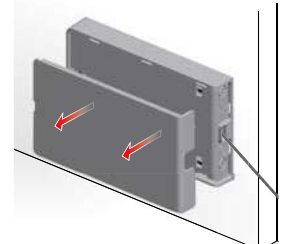





## KIARO EASY WITH KIMANA HINGE

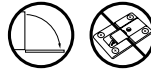

### SIDE PANEL DRILLING PLAN WITH EMBEDDED DOOR BRACKET

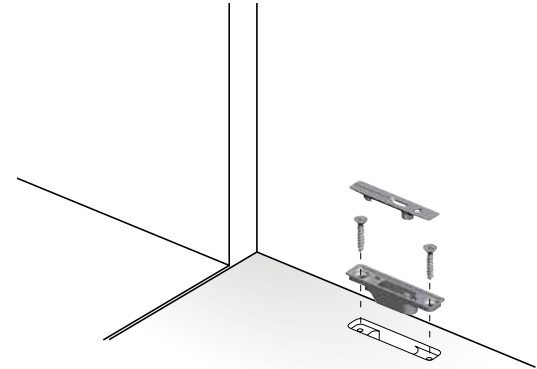
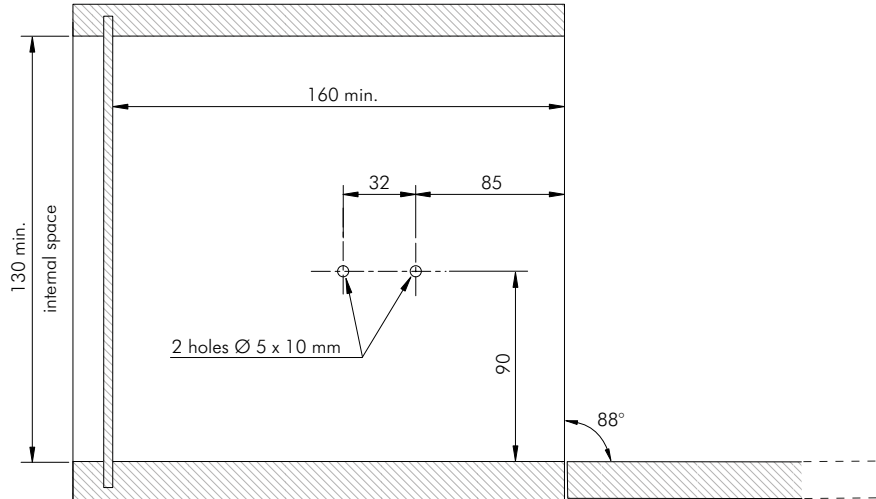

Overcrossing 90° door opening angle, negatively affects the Kimana hinges.

### SIDE PANEL DRILLING PLAN WITH SCREW FIXING DOOR BRACKET

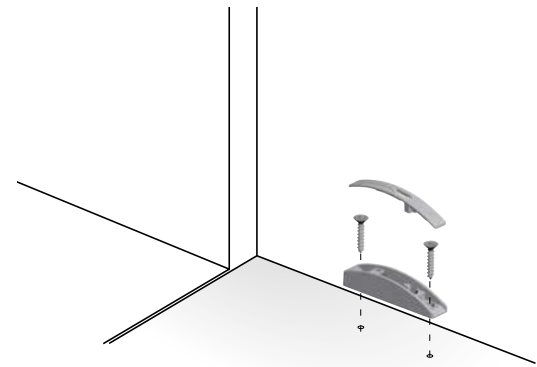
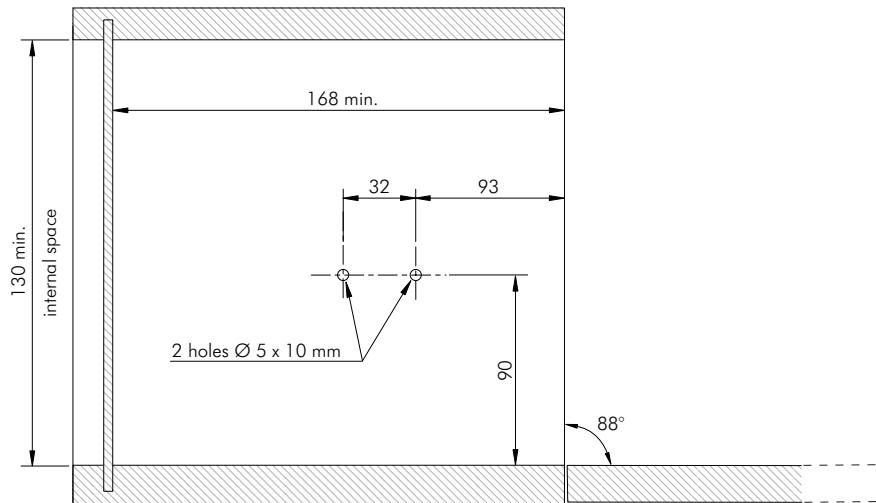

Overcrossing 90° door opening angle, negatively affects the Kimana hinges.



In case of door without handles it is recommended to use **K Push Tech with buffer**.

## KIARO EASY WITH STANDARD UNSPRUNG HINGES

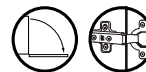

In case the hinges to be installed are not KIMANA hinges, please contact our technical department to receive the correct drilling plan. It is necessary to indicate all the values requested in the following diagram:

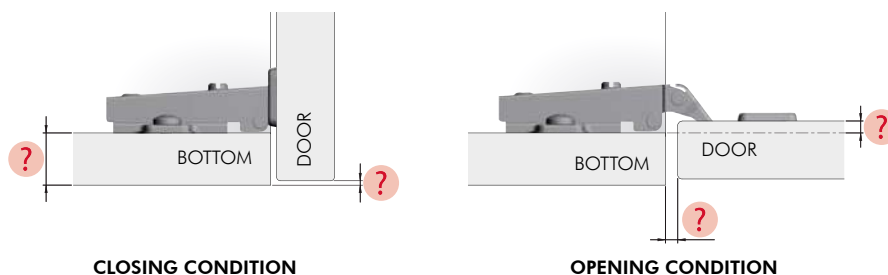

## KIARO EASY MECHANISM

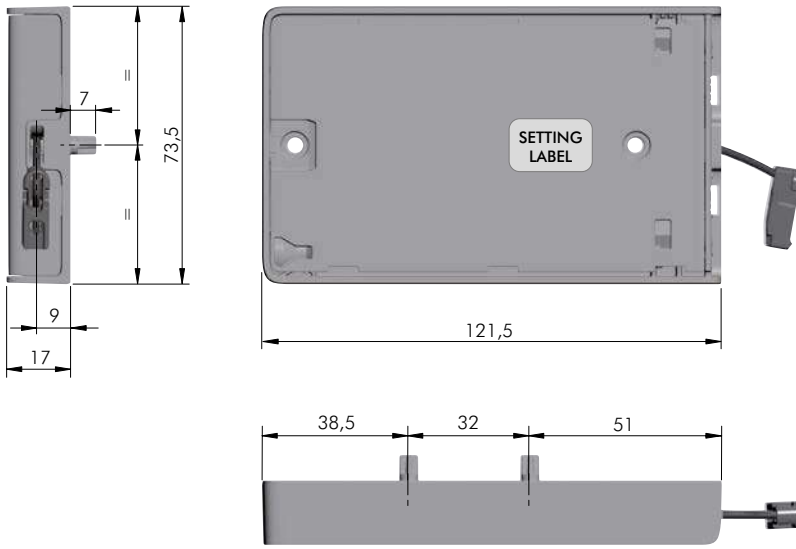

ZA	EP	ST	= 20 pcs.	
49504000EE	EW	LD	AB	Soft
49506000EE	EW	LD	AB	Strong



## KIARO EASY COVER

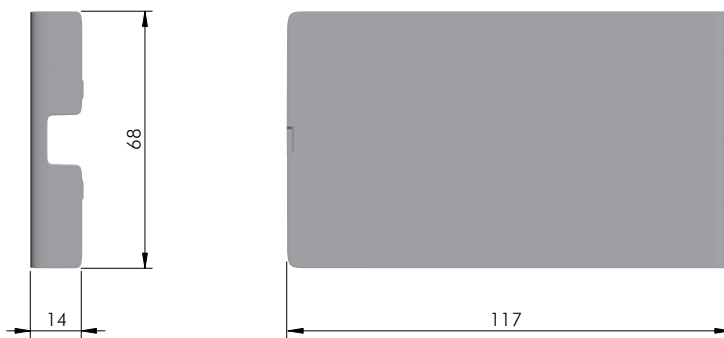

EP	= 20 pcs.			
49502000EE	EW	LD	AB	

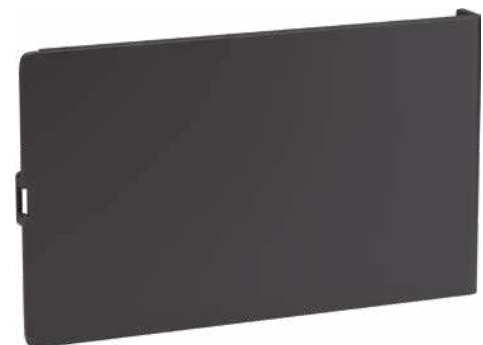

8



## EMBEDDED DOOR BRACKET

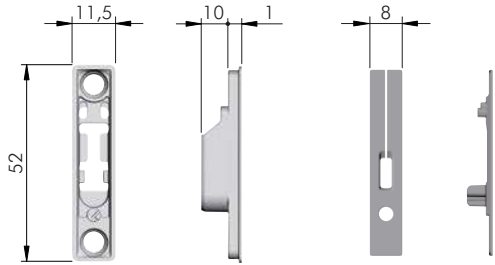

= Ø 2,5 mm

ZA EP

= 20 pcs.



49503000YQ

EE

YQ

49503000YA

EW

YA

49503010YQ

LD

YQ

49503010YA

AB

YA

### DOOR PANEL DRILLING OPERATIONS

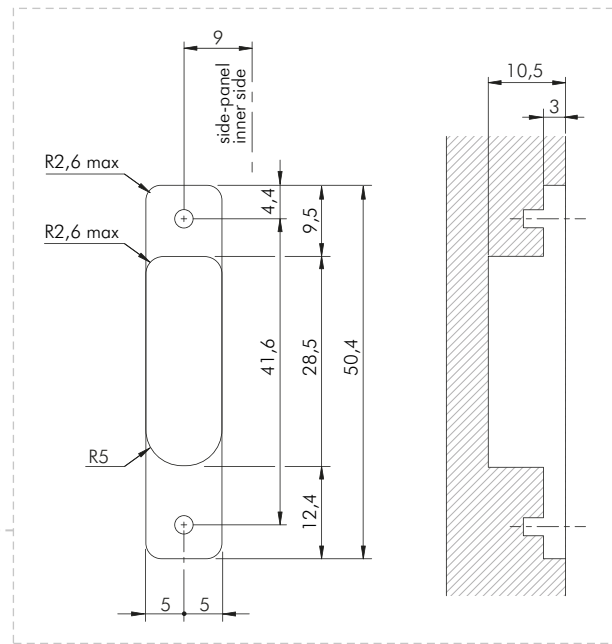
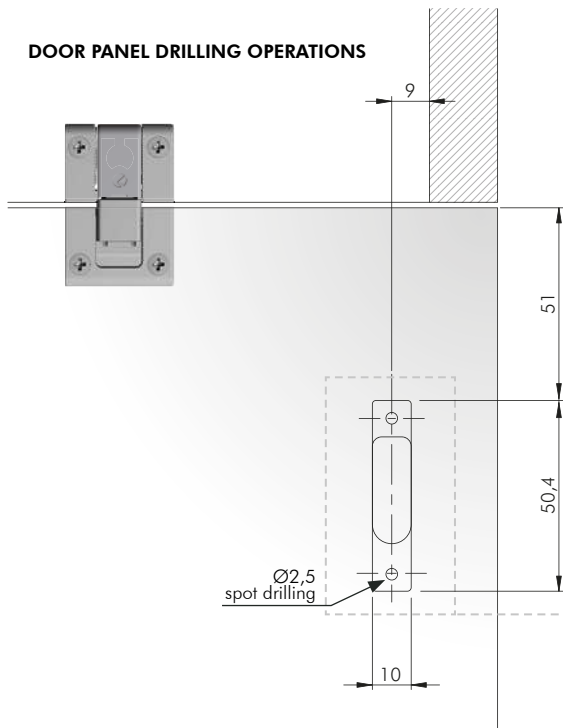

## SCREW FIXING DOOR BRACKET

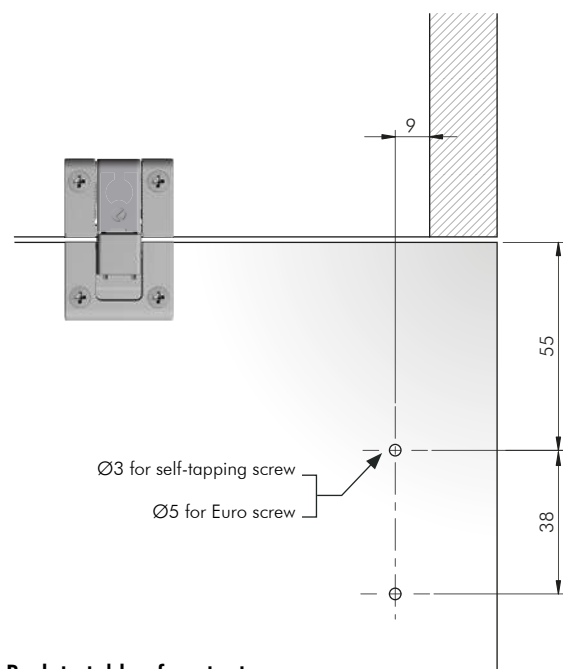

= Ø 3 mm, Ø 5 mm

ZA EP

= 20 pcs.



49503500YQ

EE

YQ

49503500YA

EW

YA

49503510YQ

LD

YQ

49503510YA





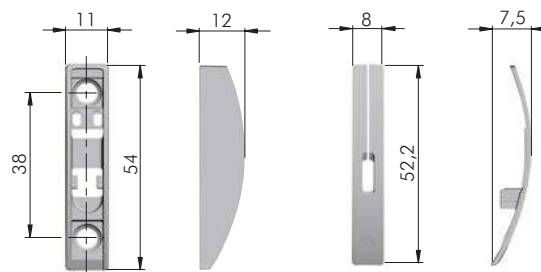



AB

YA











## ACCESSORY FOR MECHANISM FIXING



 = Ø 3 mm	
   = PZ2	
	 = 10.000 pcs.
 	
<b>60103160ZN</b>	









## ACCESSORIES FOR DOOR BRACKET FIXING



 = Ø 3 mm	
   = PZ2	
	 = 10.000 pcs.
 	
<b>60101390ZN</b>	

8



 = Ø 5 mm	
   = PZ2	
	 = 5000 pcs.
 	
<b>60503050ZN</b>	



## DOOR BRACKET ACCESSORY FOR DOORS WITH ALUMINIUM PROFILE



### DOOR BRACKET INSTALLATION

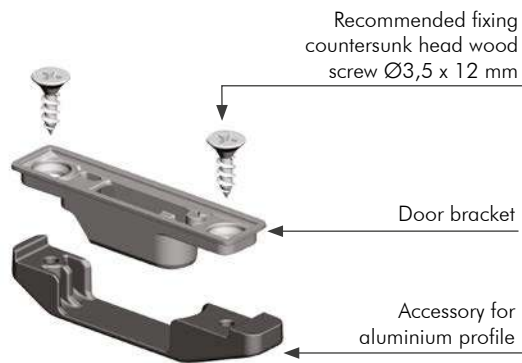

### DOOR SPECIFICATION

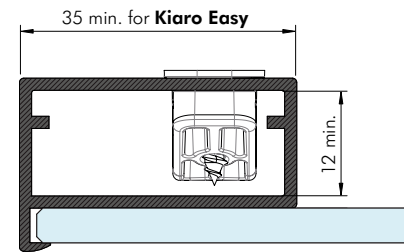

Join the door bracket with the accessory keeping the screws loose

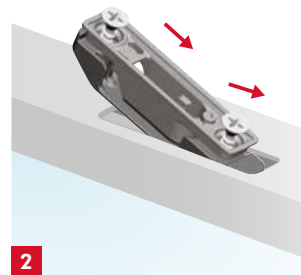
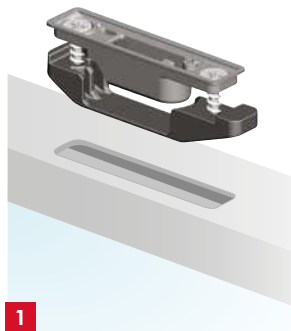



# OPENING SYSTEMS FOR LIFT UP AND DROP DOWN DOORS

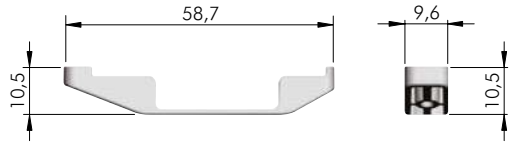

EP	= 1500 pcs.
<b>4630208000</b>	

## DRILLING PLAN FOR KIARO EASY

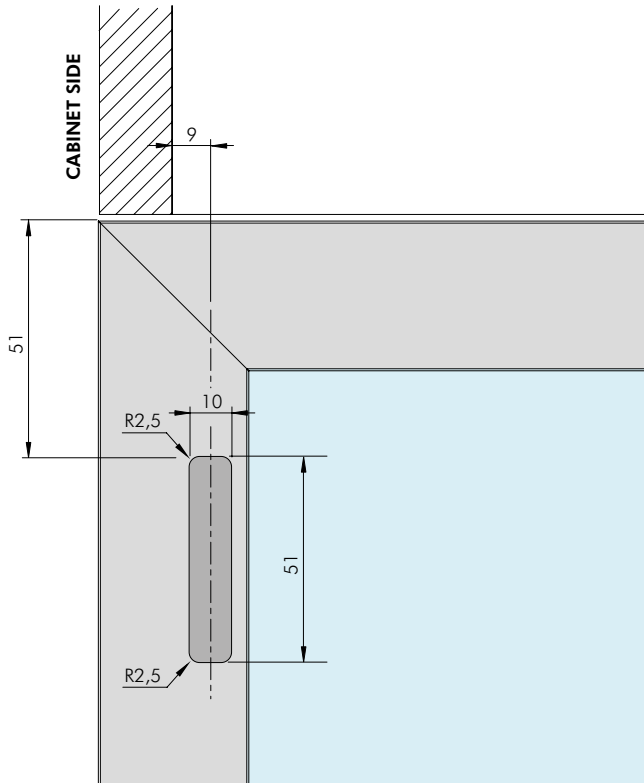

8

## FIXING ACCESSORY

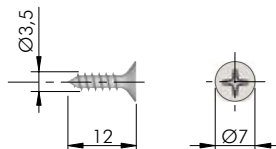

= Ø 3 mm	
= PZ2	
ST	= 10.000 pcs.
<b>60101380ZN</b>	