

PS03

Sistema scorrevole per ante in luce o a ridosso.

Sliding system for front or inside doors.

Système coulissant pour portes avec ouvertures vers l'intérieur ou l'extérieur.

Laufsystem für einliegende oder aufschlagende Türen.

Sistema corredizo par puertas internas o delanteras.

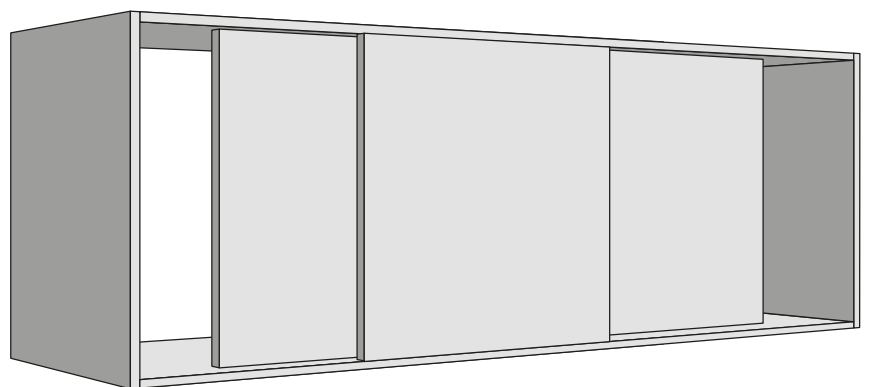
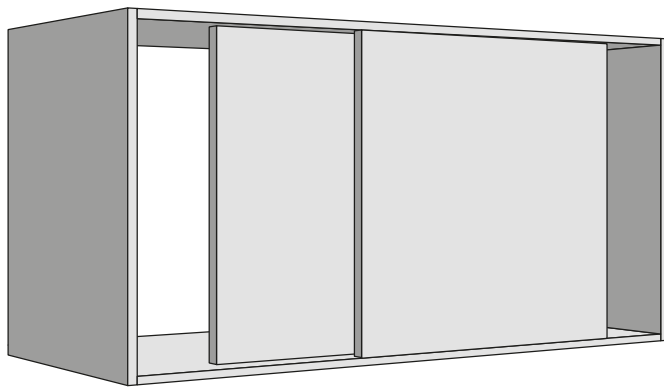

Istruzioni di montaggio

Assembly instructions

Instructions de montage

Montageanleitungen

Instrucciones des ensamblaje





Italiano

Tutte le misure espresse in questo opuscolo sono in millimetri.

ATTENZIONE

Non utilizzare spray ed oli anti frizione o sblocca filetti sui cuscinetti o sulle ruote con O-ring dei pattini scorrevoli. Questo provoca lo scioglimento dei grassi dei cuscinetti rendendoli rumorosi oppure la rottura dell'O-ring.

ABBREVIAZIONI

W	larghezza
WA	larghezza anta
L	lunghezza
LB	lunghezza binario
D	profondità
H	altezza
I	interasse
T	spessore
S	sormonto

Le illustrazioni e le descrizioni di questo opuscolo si intendono fornite a titolo indicativo. L'azienda si riserva pertanto di apportare, in qualsiasi momento e senza preavviso, quelle modifiche che ritenesse utili per qualsiasi esigenza di carattere costruttivo e commerciale.

Deutsch

Alle Maße in diesem Katalog sind in Millimetern.

ACHTUNG

Kein Spray, Schmiermittel oder Lösenmittel auf die Kugellager und Rollen mit O-Ring der Laufwagen verwenden. Das kann die Kugellager und die Rollen geräuschvoller machen und kann den O-Ring Abriss verursachen.

ABKÜRZUNGS

W	Breite
WA	Türbreite
L	Länge
LB	Länge Schienen
D	Tiefe
H	Höhe
I	Abstand zwischen den Zentren
T	Dicke
S	Überlappung

Die Bilder und Beschreibungen dieses Prospektes sind nur zur Information gegeben. Die Firma kann, in jedem Moment, Änderungen und Verbesserungen ohne Vorankündigung vornehmen.

English

All dimensions in this leaflet are stated in millimeters.

WARNING

Do not use any anti-friction oil or grease or thread-release spray on ball bearing or on wheels with O-ring, it can cause the melting of the inside ball bearing grease, making them noisy or causing the break of the O-ring of the wheels.

ABBREVIATIONS

W	width
WA	door width
L	length
LB	rail length
D	depth
H	height
I	distance between centres
T	thickness
S	overlapping

The pictures and descriptions this leaflet contains are supplied for information purposes. The company reserves the right to introduce those modifications it deems opportune for any construction or commercial need at any time and without advance notice.

Español

Todas las dimensiones en este folleto se expresan en milímetros.

ADVERTENCIA

No utilices spray y aceites anti-fricción sobre los cojinetes de bolas y sobre las ruedas con O-ring de los patines. Esto puede provocar mayor rumorosidad de los cojines o la rotura de los O-ring.

ABREVIACIONES

W	anchura
WA	anchura de la puerta
L	longitud
LB	longitud de la guía
D	profundidad
H	altura
I	distancia entre centros
T	espesor
S	superposición

Las imagines y las descripciones de este folleto solo se fechas a título informativo. La empresa puede aportar, en cualquier momento y sin preaviso, las modificaciones que cree necesarias por exigencias técnicas y comerciales.

Français

Toutes les mesures indiquées dans cette brochure sont en millimètres.

AVERTISSEMENT

Ne pas utiliser de spray ni d'huile anti frottement ou pour débloquer les filets sur les coussinets ou sur les roulettes avec bague torique des patins coulissants. Ce qui ferait fondre la graisse des roulements en les rendant bruyants ou provoquerait la rupture de la bague torique.

ABRÉVIATIONS

W	largeur
WA	largeur de la porte
L	longueur
LB	longueur de le rail
D	profondeur
H	hauteur
I	entraxe
T	épaisseur
S	chevauchement

Les images et les descriptions de cette notice ne sont fournies qu'à titre indicatif. Le fabricant se réserve donc le droit d'apporter toutes les modifications qu'il jugera utiles à des fins techniques et commerciales à n'importe quel moment et sans aucun préavis.

Lavorazioni richieste per le ante.

Working requests for the doors.

Usinage nécessaire pour les portes.

Verarbeitungsanforderungen für die Türen.

Laboreo necesario para las puertas.

1

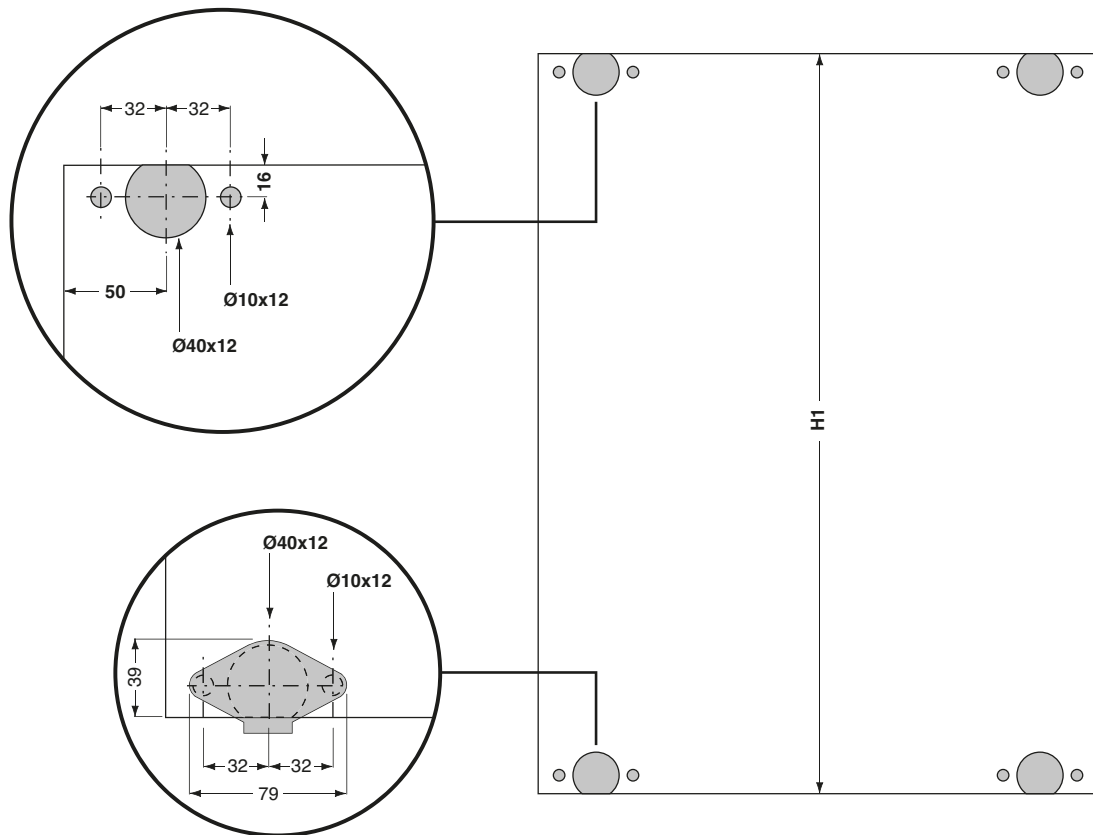
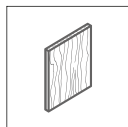
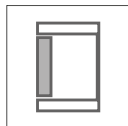

1a

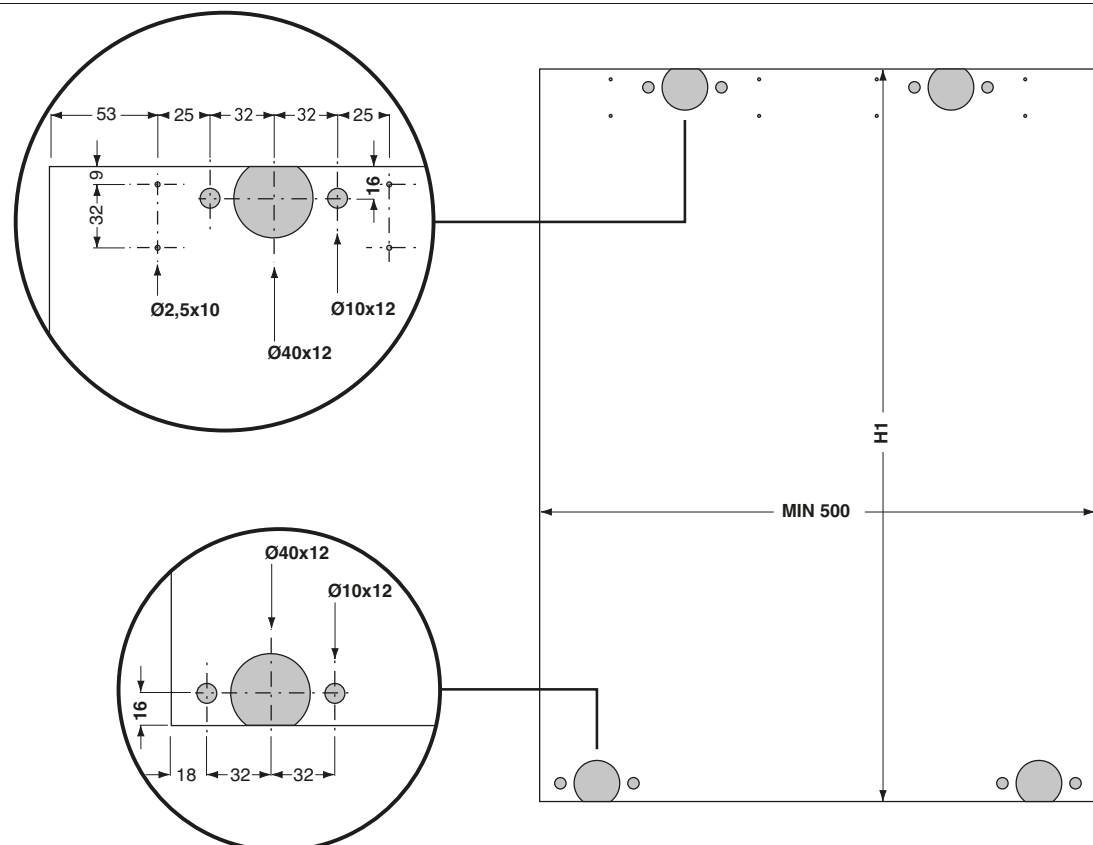
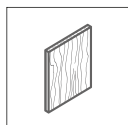
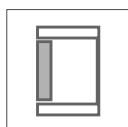

2

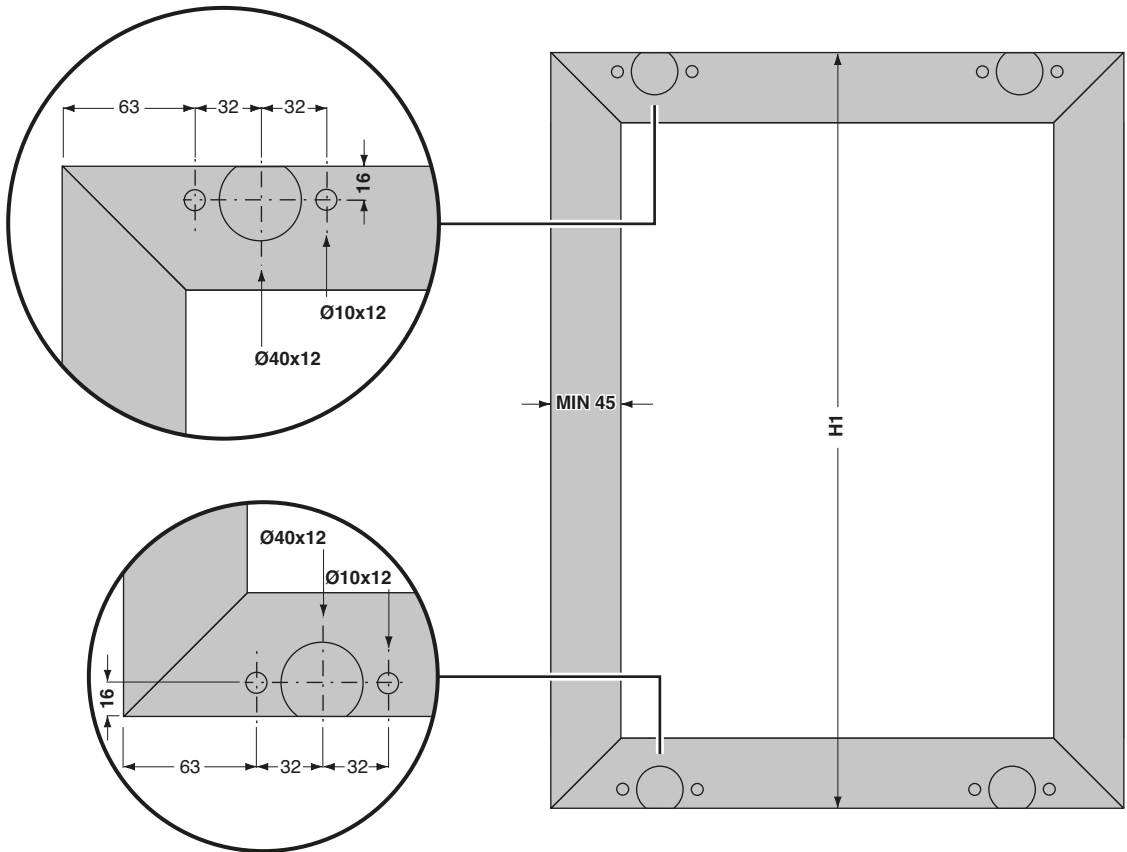
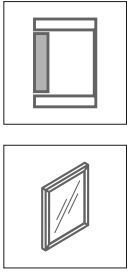

2a

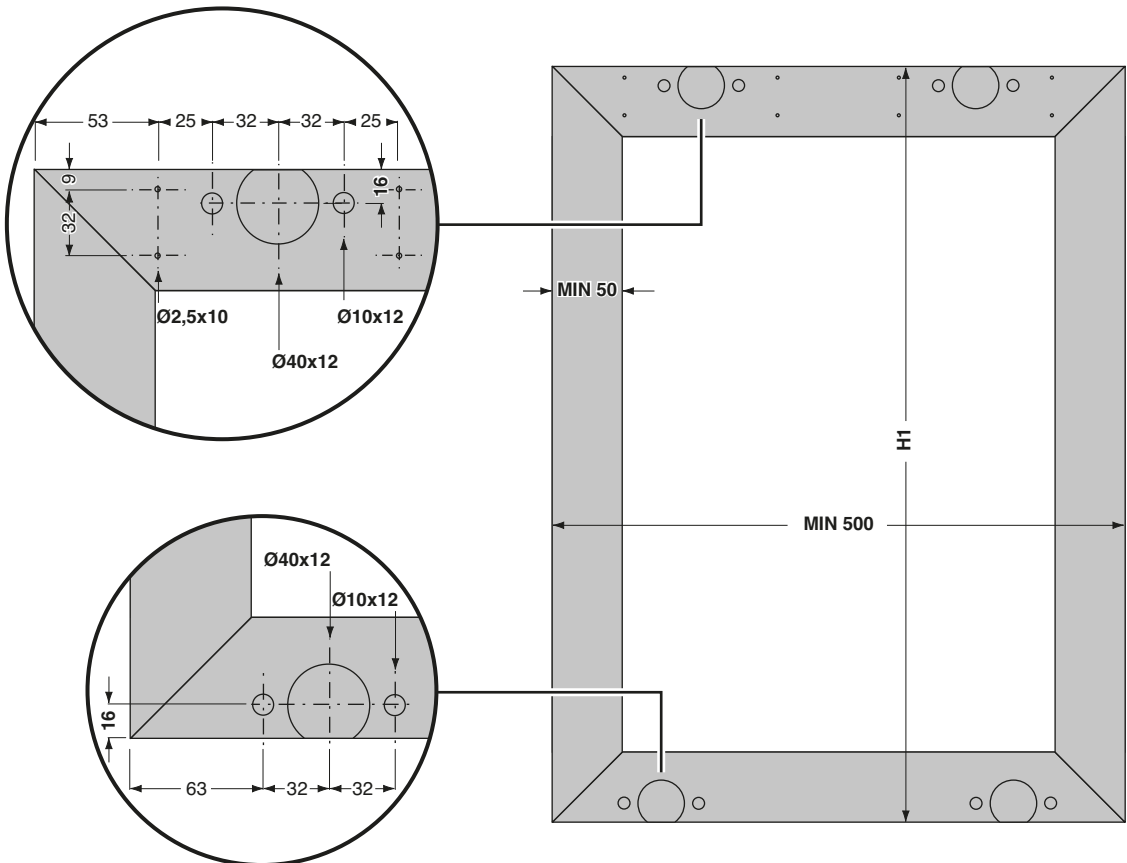
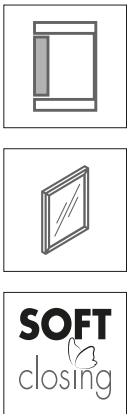

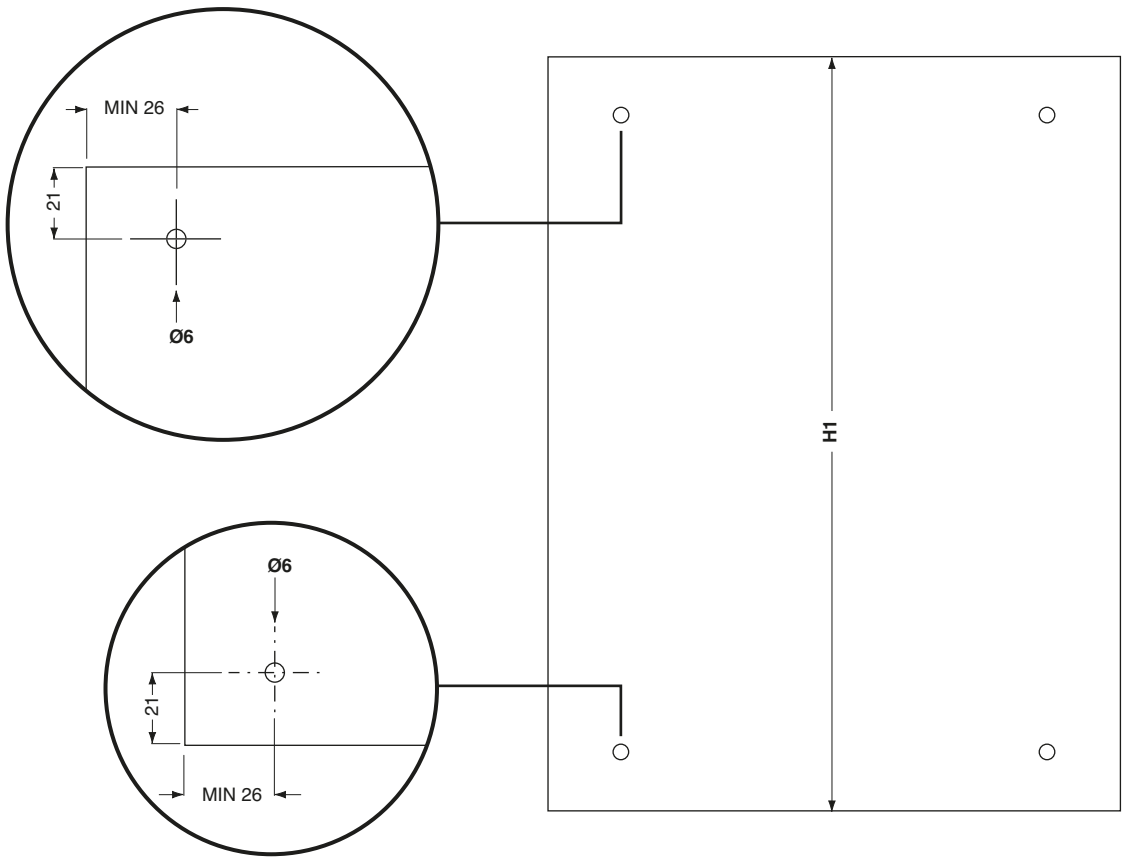
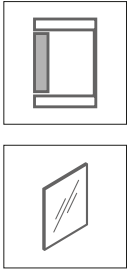

Schemi posizionamento sistema di ammortizzazione e attivatori.

Positioning of soft-closing device and activators.

Schémas de positionnement système amortissement et activateurs.

Schemen zur Positionierung des Dämpfungssystems und der Aktivatoren.

Esquemas de colocación del sistema de amortización y activadores.

1

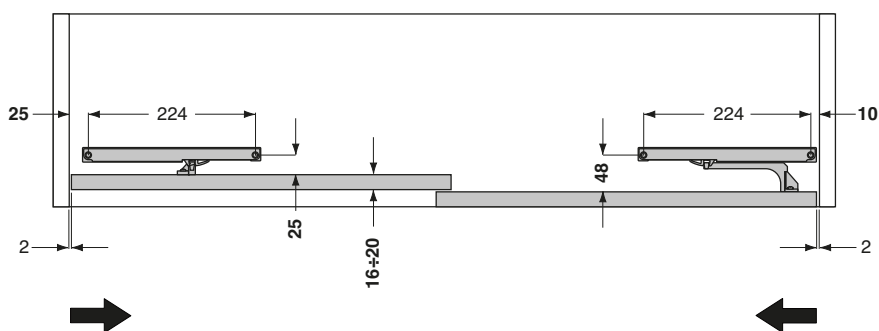
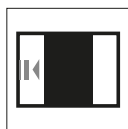
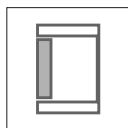

2

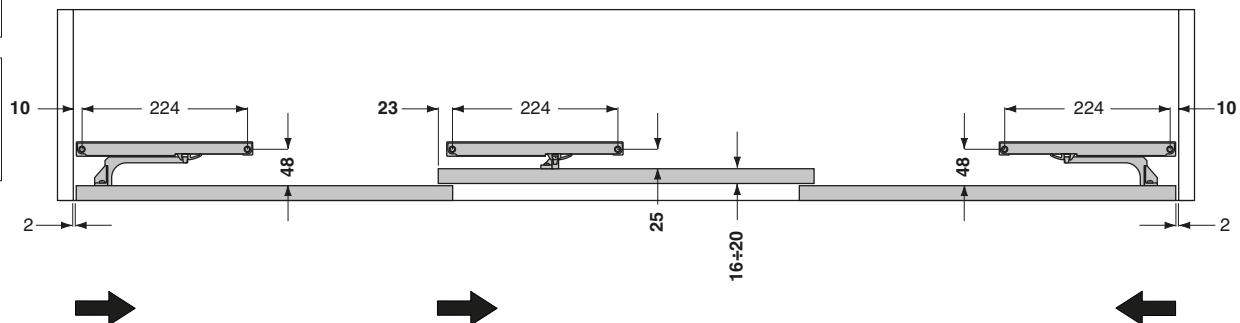
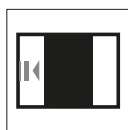
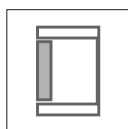

3

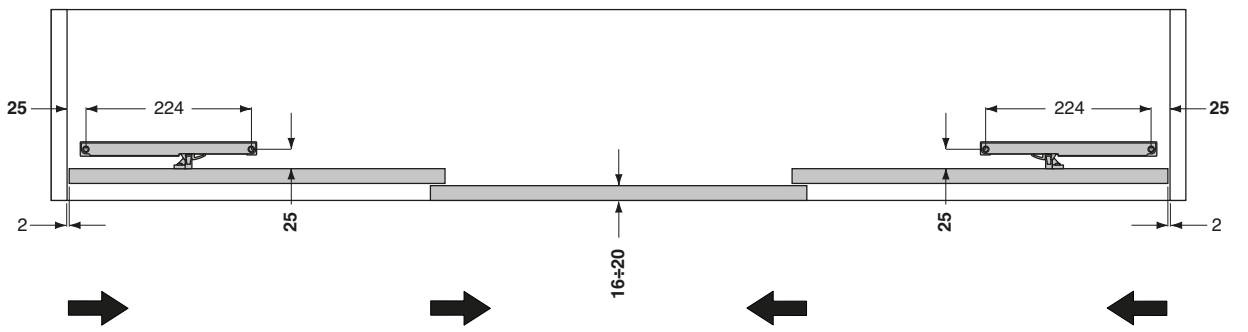
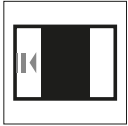
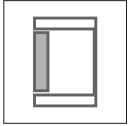



Istruzioni di montaggio
Assembly instructions
Instructions de montage
Montageanleitungen
Instrucciones de ensamblaje

1

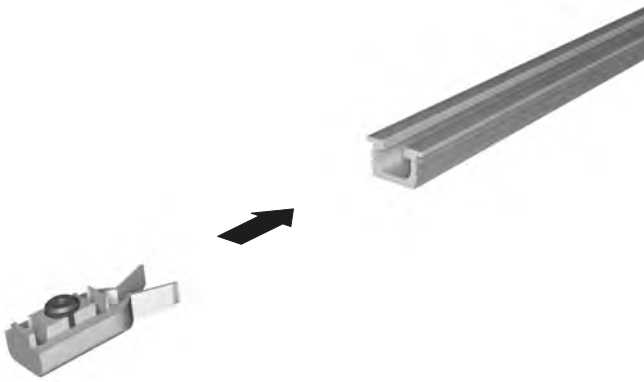

2



3a

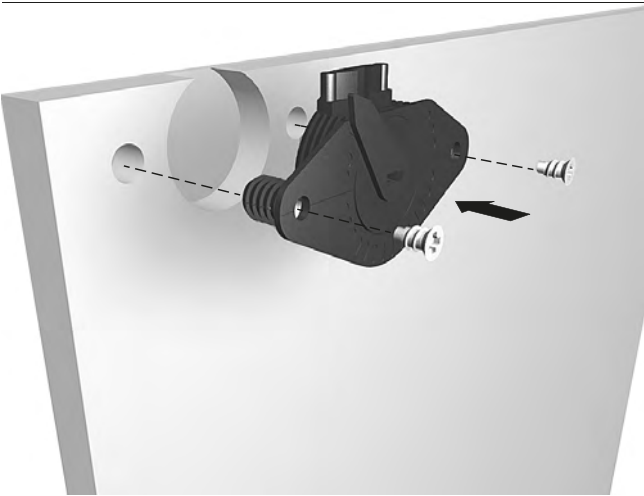

3b

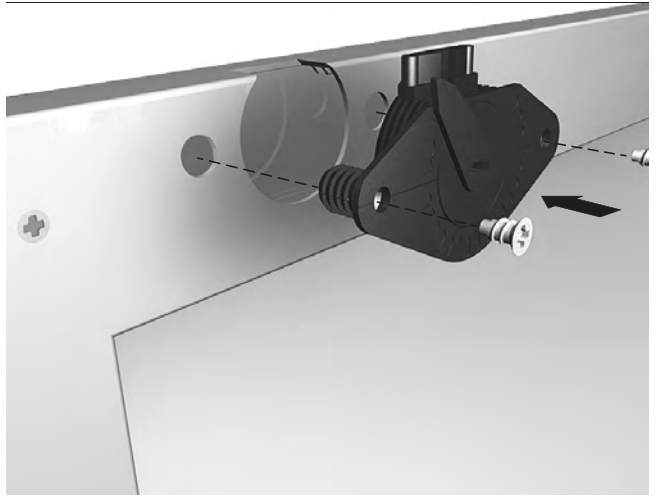

4a

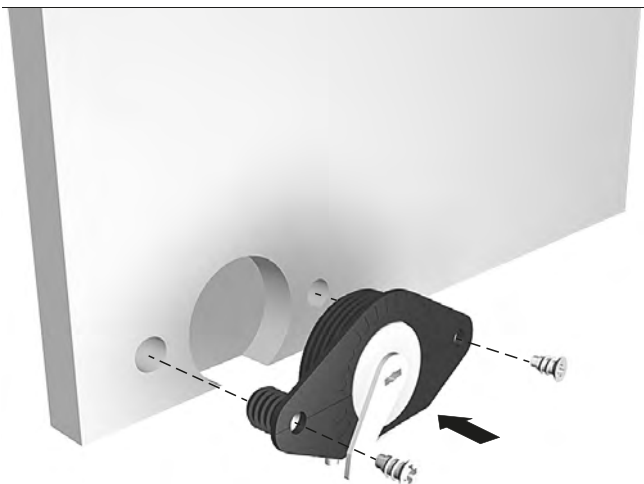

4b

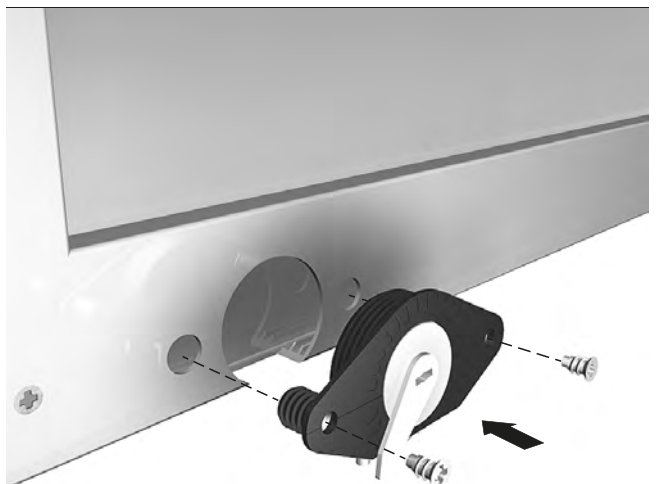

5

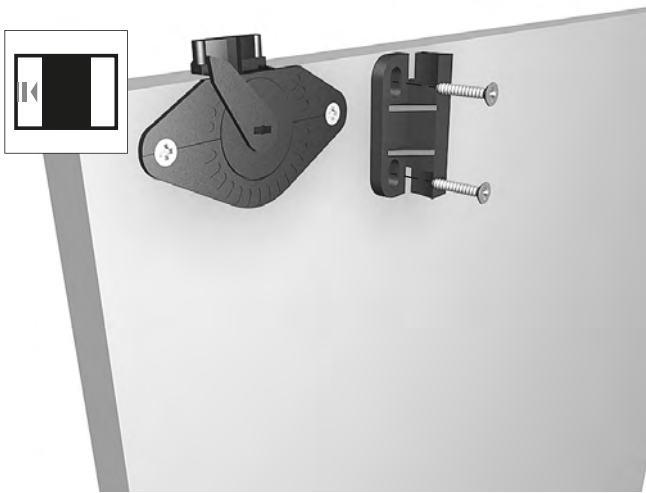

6

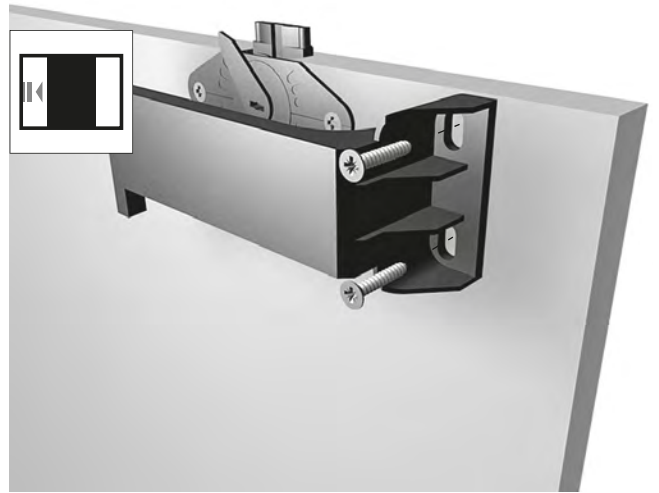

7

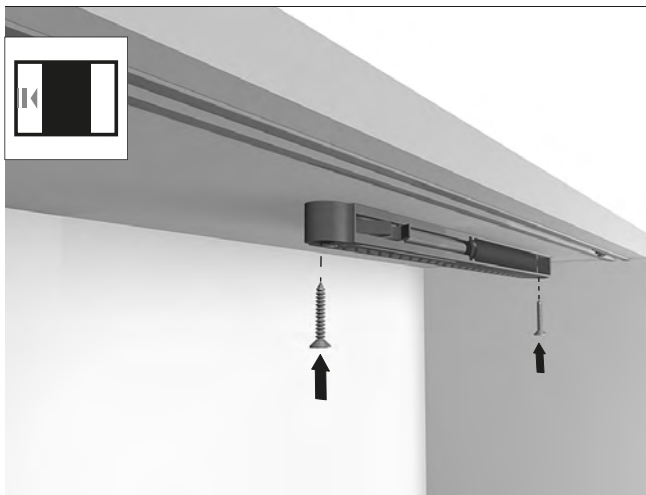

8

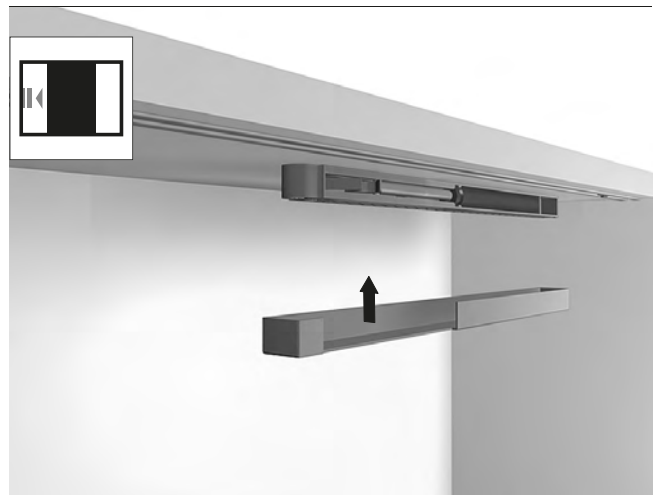

9

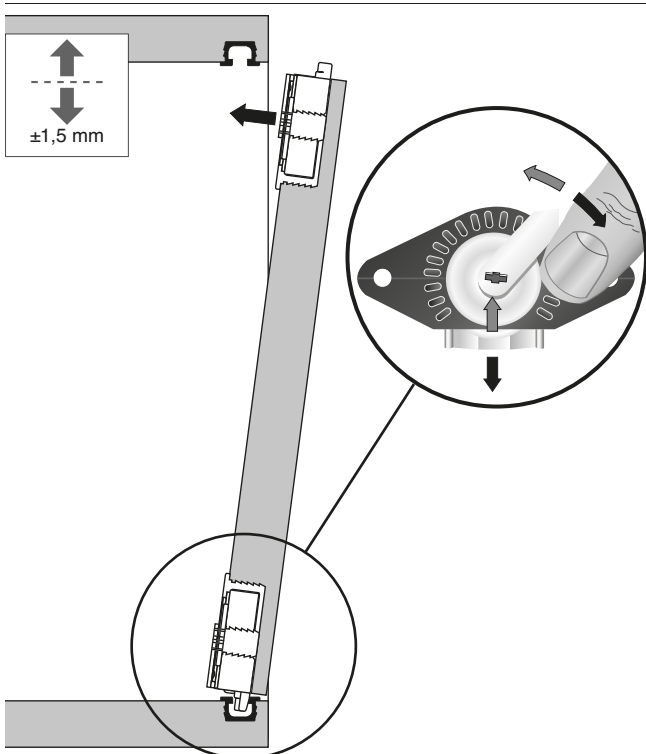

10

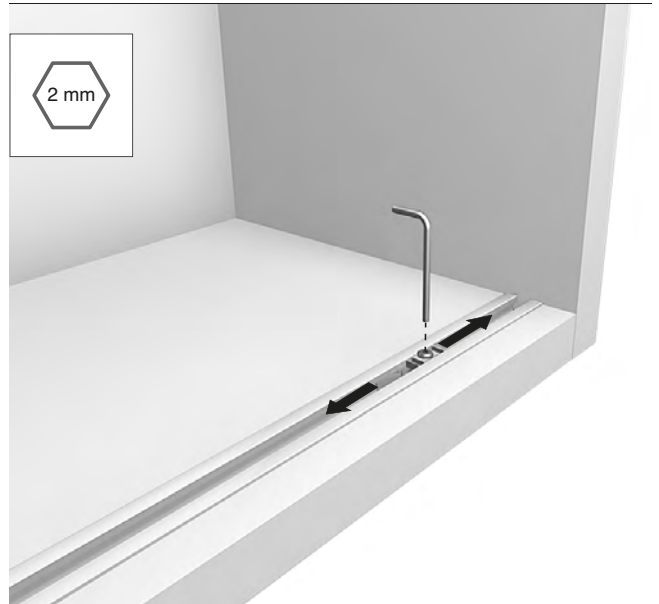

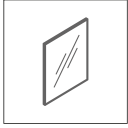

Istruzioni di montaggio

Assembly instructions

Instructions de montage

Montageanleitungen

Instrucciones des ensamblaje

1

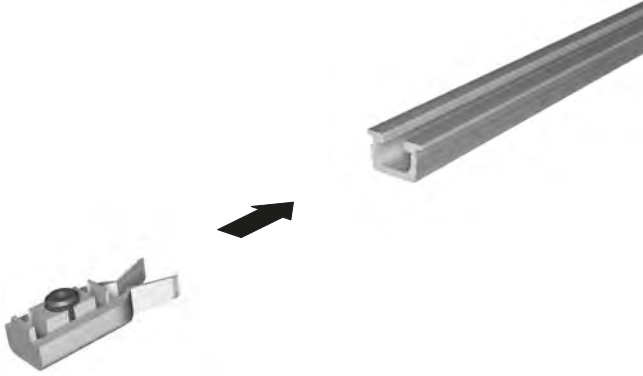

2



3



4

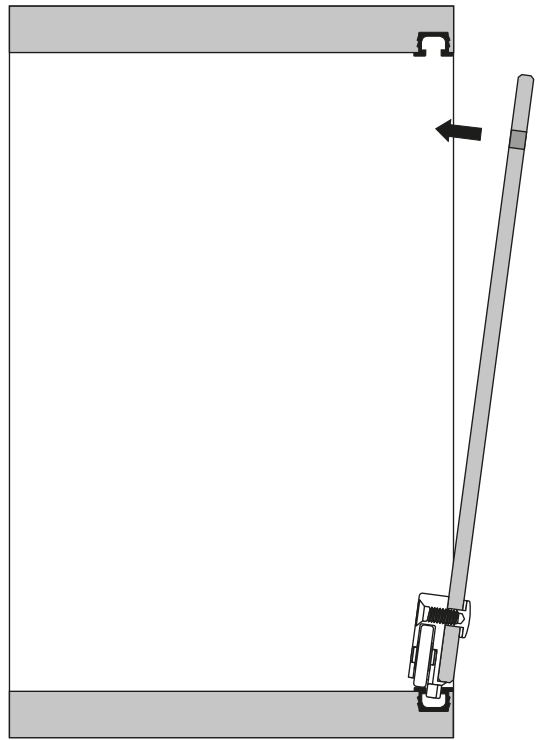

5

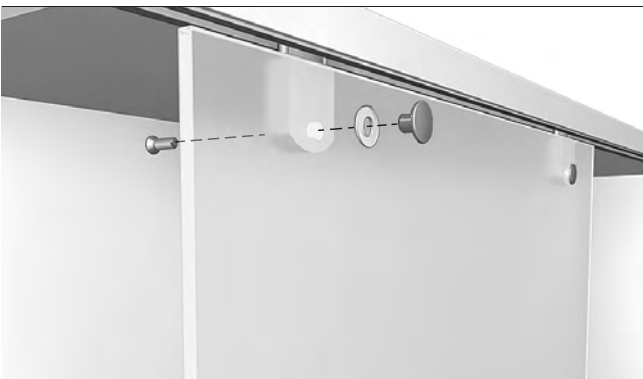

6



Icone
Icons
Icônes
Icons
Iconos

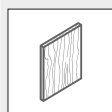

Anta in legno
Wooden door
Porte en bois
Holztür
Puerta de madera

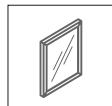

Anta in alluminio
Aluminium frame door
Porte en aluminium
Aluminiumtür
Puerta de aluminio



Per ante in legno e alluminio
For wooden and aluminium frame doors
Pour portes en bois et aluminium
Für Türen aus Holz und Aluminium
Para puertas de madera y aluminio

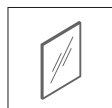

Anta in vetro
Glass door
Porte en verre
Glastür
Puerta de vidrio

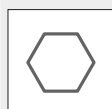

Chiave esagonale
Allen-key
Clé hexagonale
Sechskantenschlüssel
Llave hexagonal

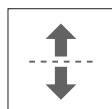

Regolazione verticale
Vertical adjustment
Ajustement vertical
Höhenverstellung
Regulación vertical



Sistema di ammortizzazione monodirezionale
One-way soft-closing device
Système d'amortissement monodirectionnel
Unidirektionales Dämpfungssystem
Sistema de amortización monodireccional

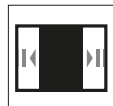

Sistema di ammortizzazione bidirezionale
Two-way soft-closing device
Système d'amortissement bidirectionnel
Bidirektionales Dämpfungssystem
Sistema de amortización bidireccional



Sistema di ammortizzazione "soft-closing"
Soft-closing device
Système d'amortissement "soft-closing"
"Soft-closing" Dämpfungssystem
Sistema de amortización "soft-closing"

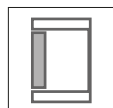

Anta in luce
Inside door
Porte intérieur
Einliegende Türen
Puerta interiores



Binario superiore - inferiore
Upper - lower rail
Rail supérieur - inférieur
Obere - untere Schiene
Raíl superior - inferior



Cinetto F.lli S.r.l.
Via Rossi, 5/A
35030 Rubano (PD) Italy
Tel. +39 049 8977211
Fax +39 049 635822
www.cinetto.it
info@cinetto.it

