



# PS19

**Ante in alluminio per  
i sistemi scorrevoli  
PS40 e PS48**

Aluminium doors for the  
sliding systems PS40  
and PS48

---





# PS19

**Ante in alluminio per i sistemi scorrevoli PS40 e PS48**  
 Aluminium doors for the sliding systems PS40 and PS48

**Accessori complementari**  
 Additional accessories

- **BR - Sistema raddrizzaporte per ante in alluminio.**  
 BR - Straighten-door gear for aluminium doors.

<b>PS48</b> compatible		<b>PS40</b> compatible			
---------------------------	--	---------------------------	--	--	--



# PS19

**PS48**  
compatible

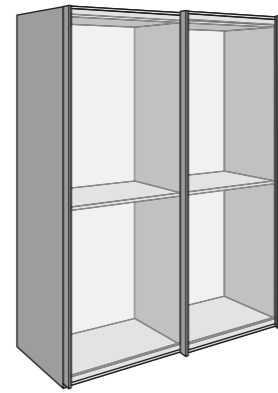

## PS19.1

8

4 mm 8+10 mm 28 mm

~~NO~~ 90°

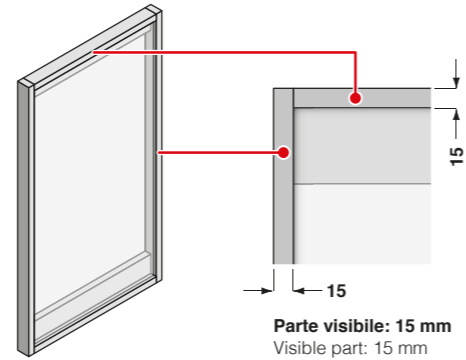

## PS19.2

20

4 mm 8+10 mm 28 mm

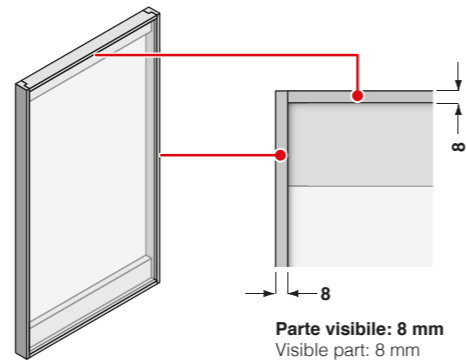

## PS19.3

36

2 levels 4 mm 18 mm 4+14 mm 43 mm

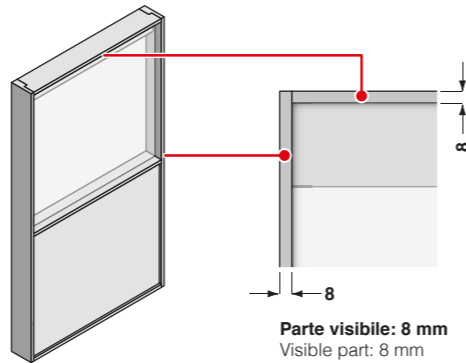

## PS19.4

50

4 mm 43 mm

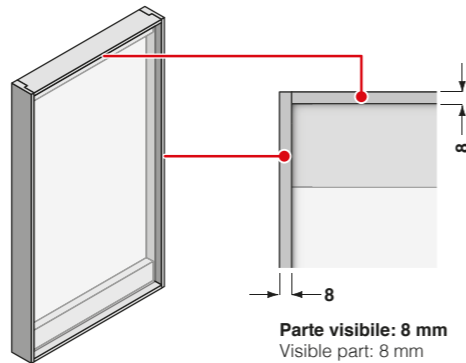

# PS19

<b>PS40</b>	106
compatible	

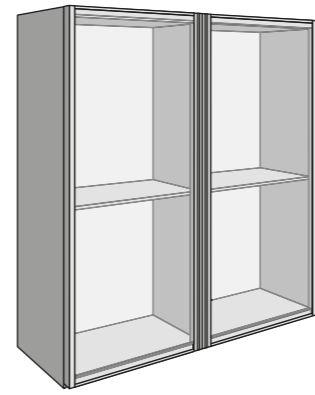

## PS19.5

62						
	4 mm	8+10 mm				
NO	90°					

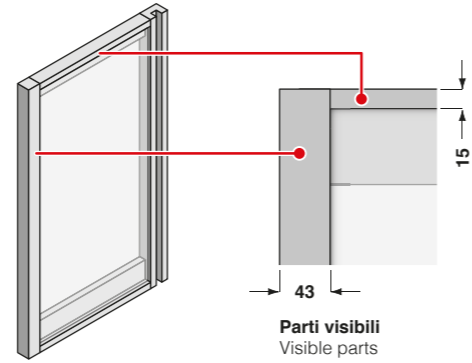

# PS19.1

**PS48**  
compatible

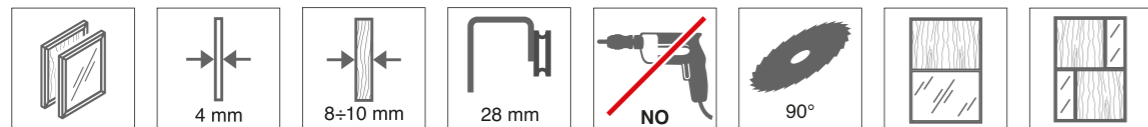
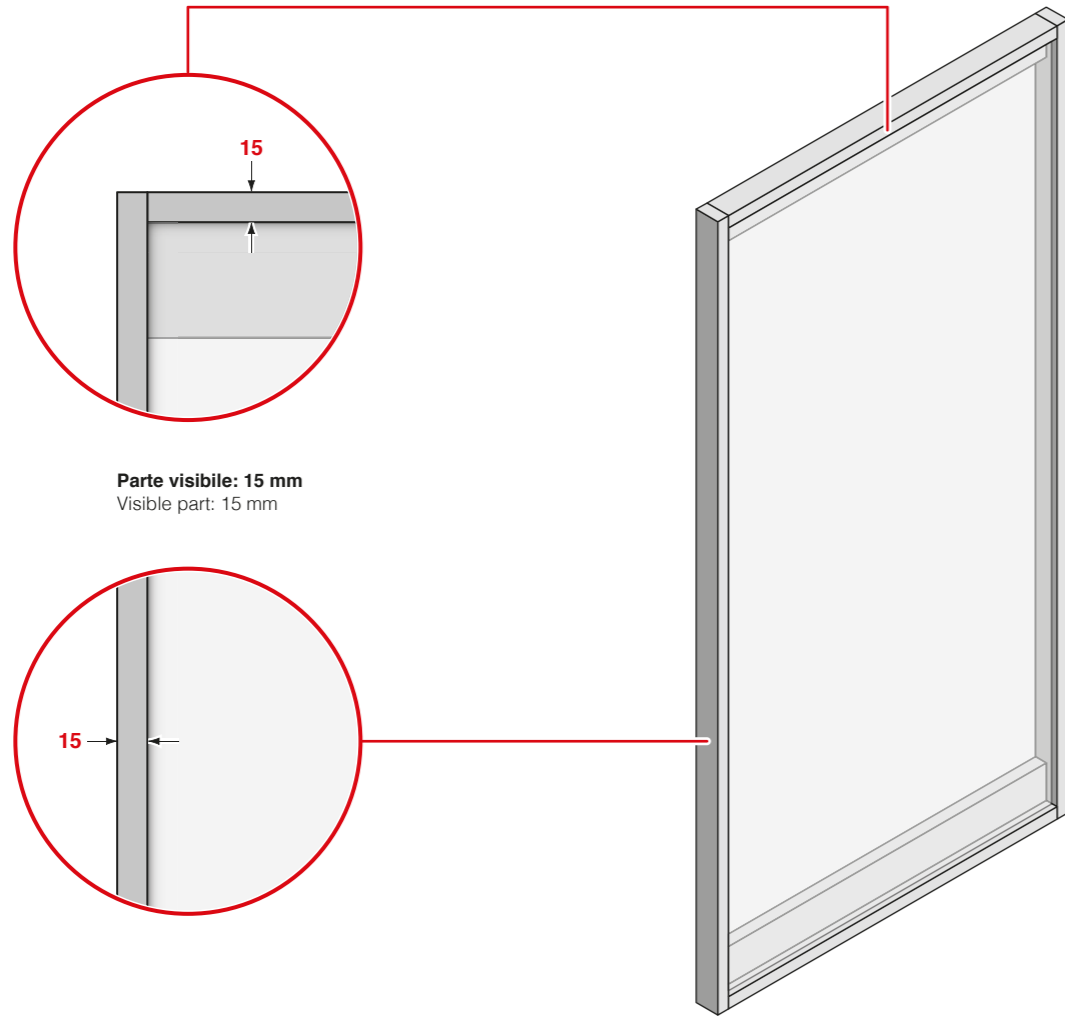
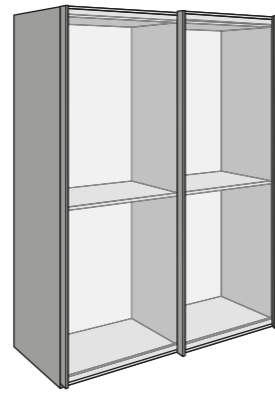

## PS19.1. Schede tecniche / Data sheets

1

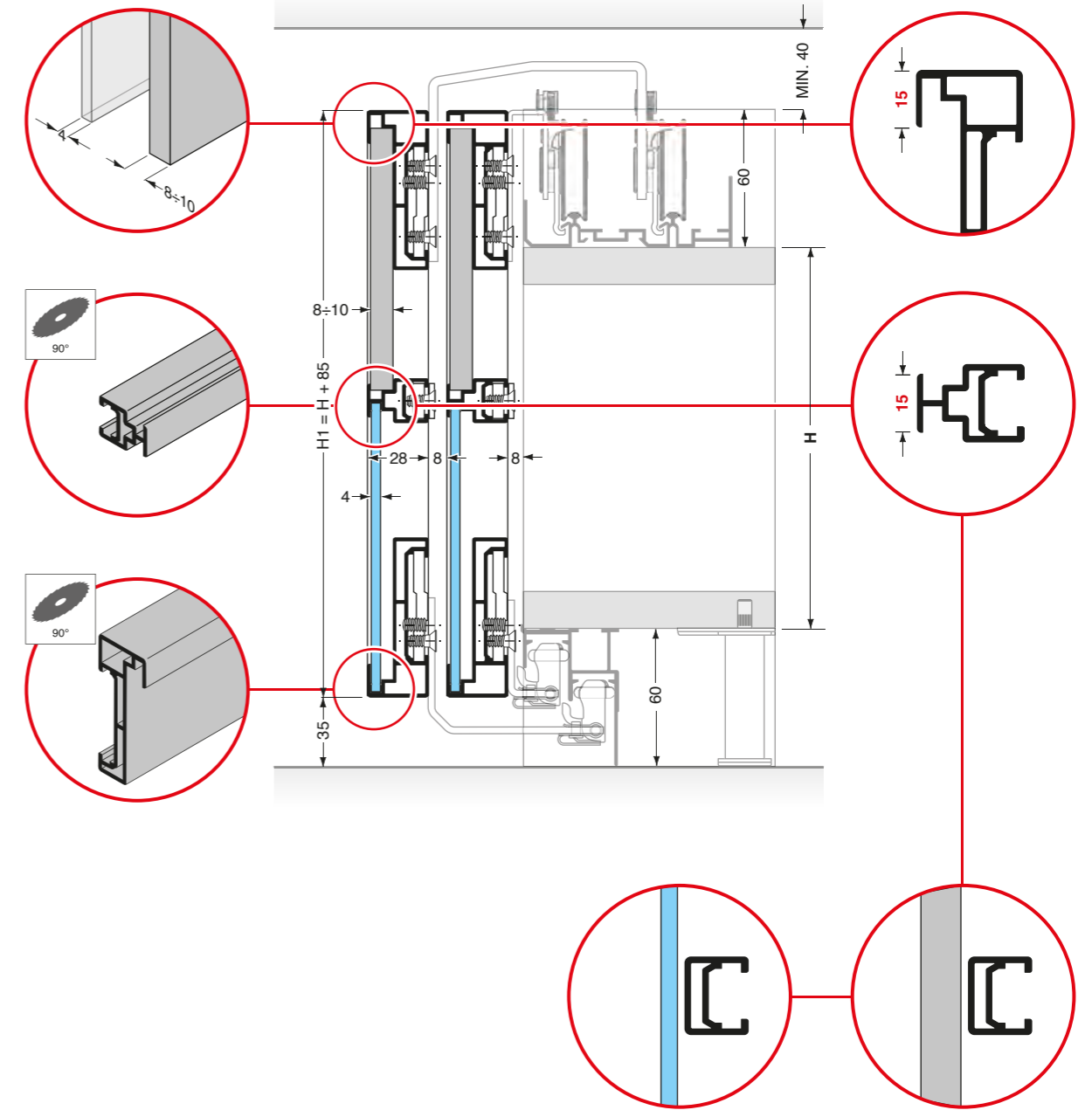

**Pattini compatibili / Compatible slides.**

PS48AP2E2801	PS48AP2E01

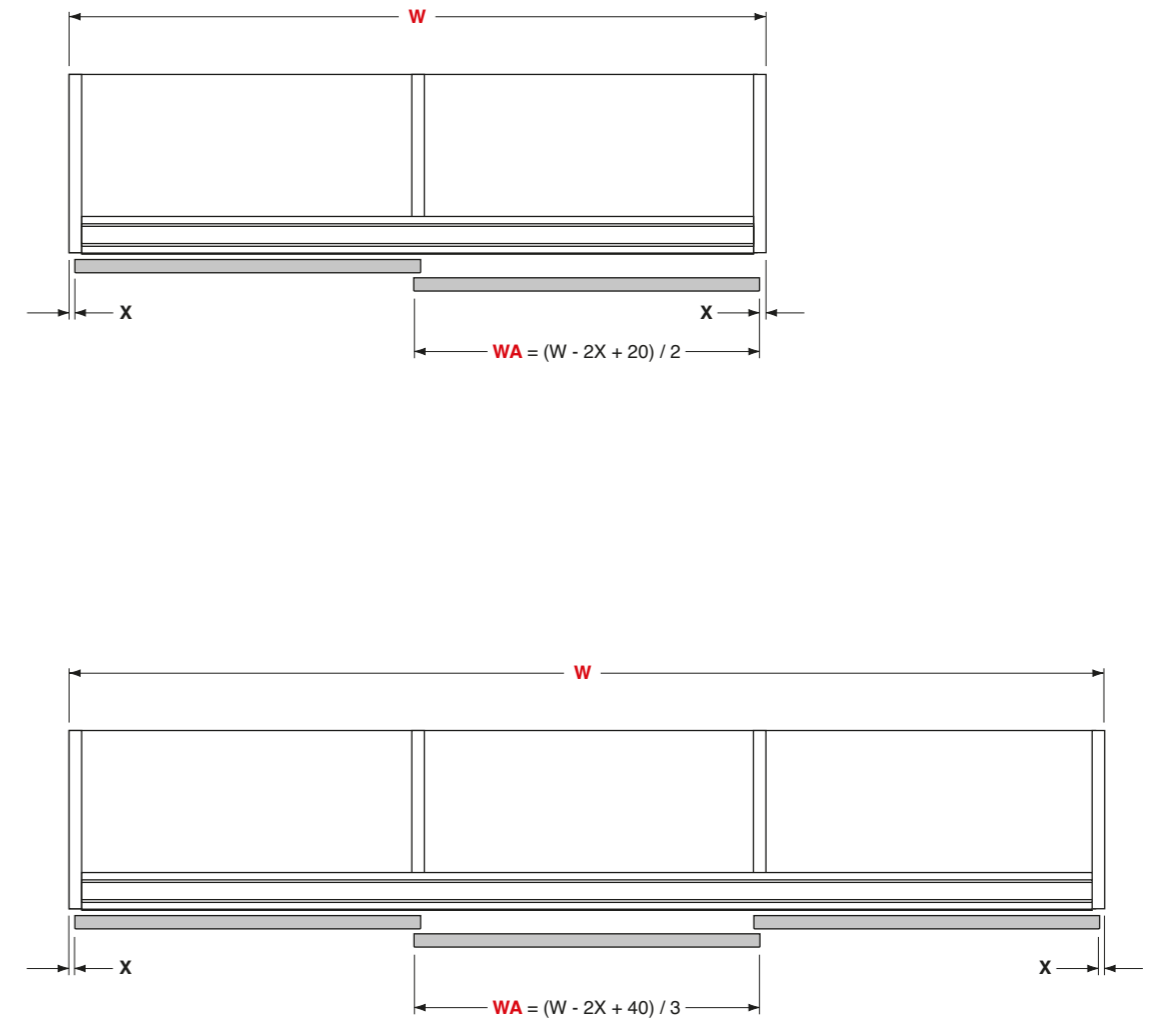
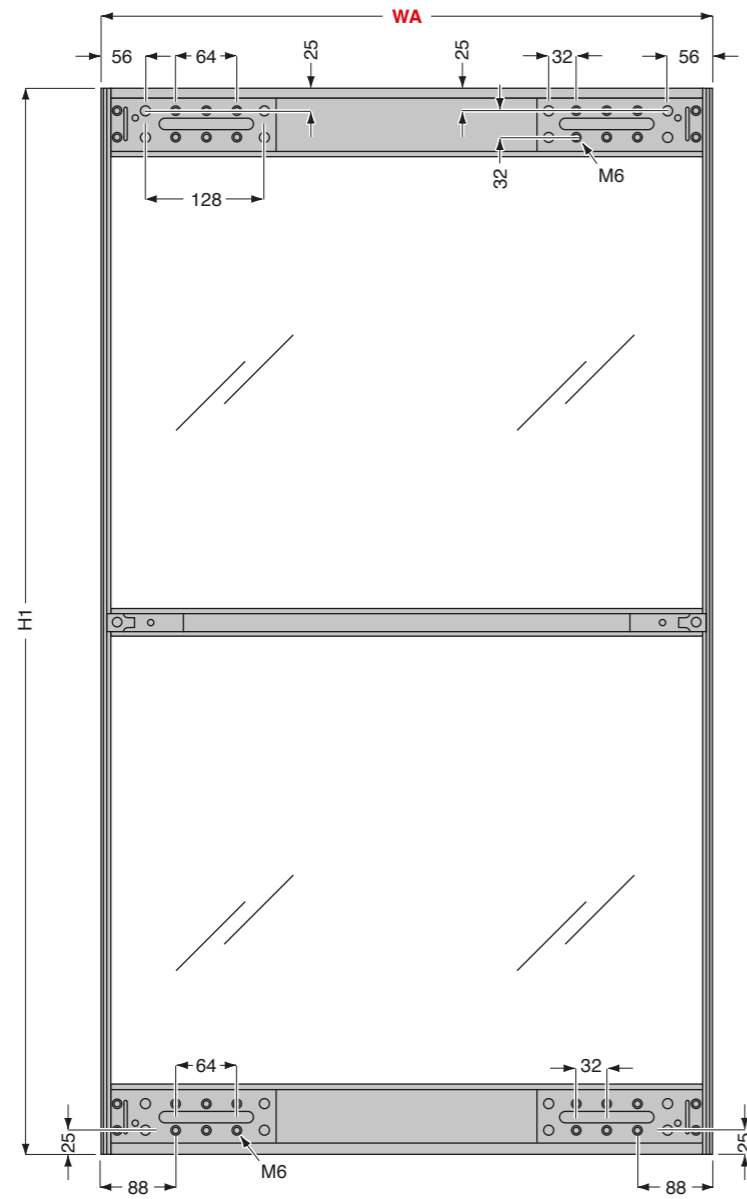

**ABBREVIAZIONI:**  
**W** = larghezza  
**WA** = larghezza anta  
**ABBREVIATIONS:**  
**W** = width  
**WA** = door width

# PS19.1

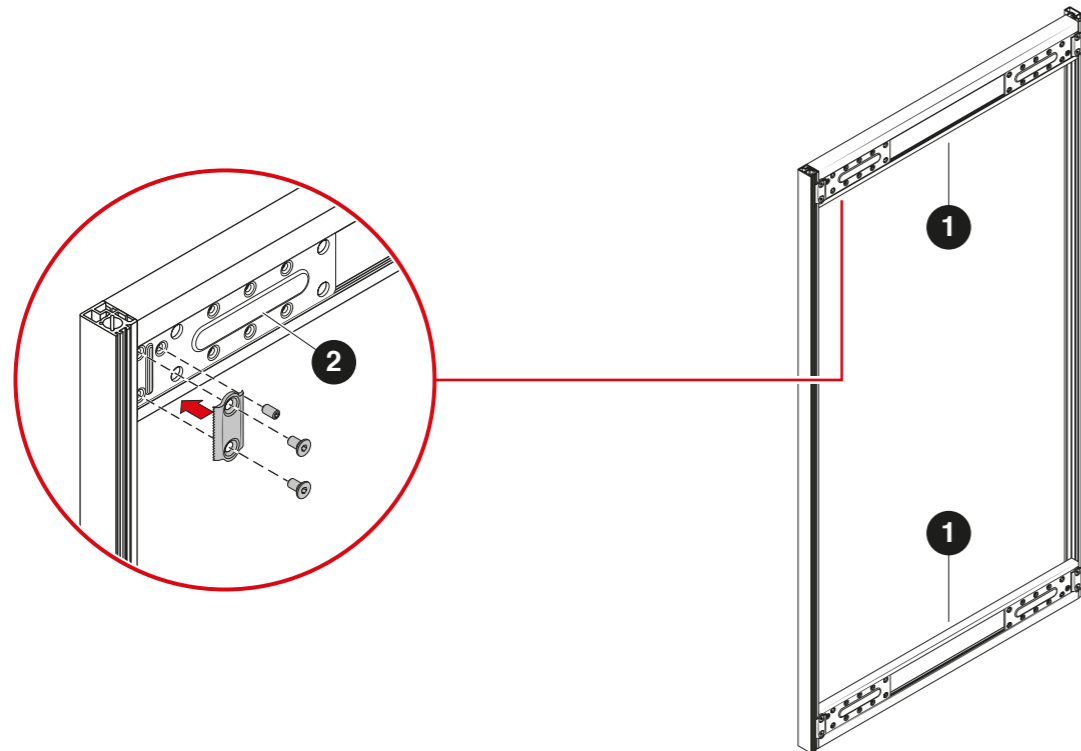
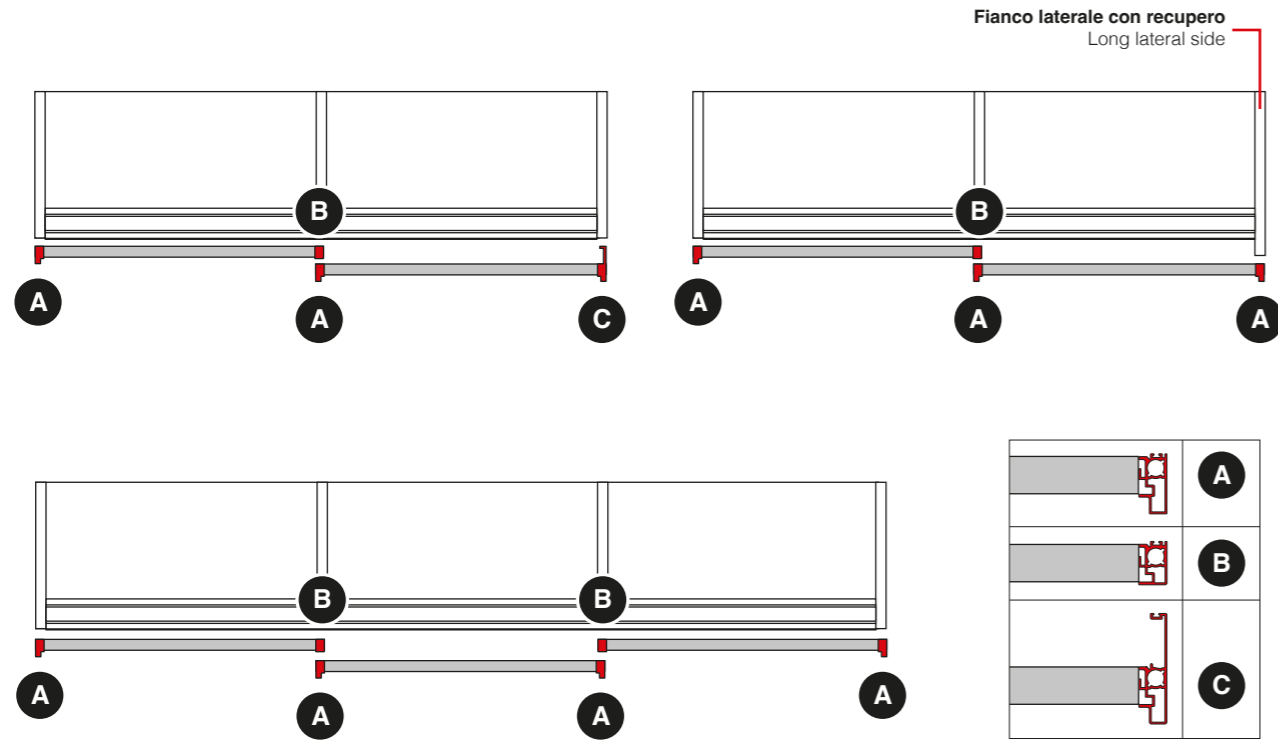
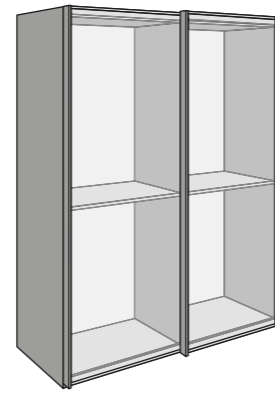

## PS19.1. Lista componenti / Parts list

### PR1970008A

Profilo maniglia bassa.

Narrow handle profile.

**Finiture standard / standard finishes**

Anodizzato / anodized: Silver  
Verniciato / painted: Deep black, Metal grey, Moonlight

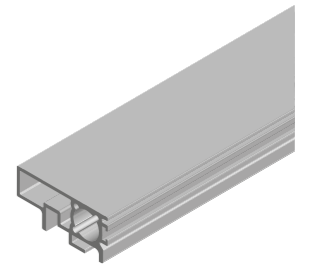
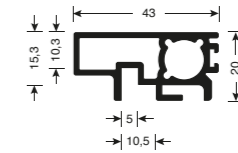

### PR1970007A

Profilo montante verticale.

Vertical rod profile.

**Finiture standard / standard finishes**

Anodizzato / anodized: Silver  
Verniciato / painted: Deep black, Metal grey, Moonlight

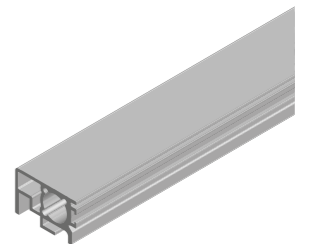
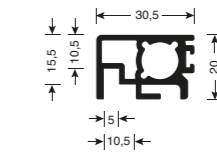

### PR1970009A

Profilo maniglia alta.

Wide handle profile.

**Finiture standard / standard finishes**

Anodizzato / anodized: Silver  
Verniciato / painted: Deep black, Metal grey, Moonlight

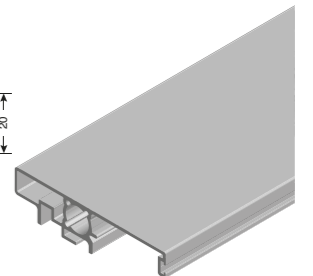
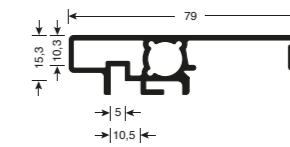

### PR1970020A

Profilo traverso superiore - inferiore.

Upper - lower horizontal profile.

**Finiture standard / standard finishes**

Anodizzato / anodized: Silver  
Verniciato / painted: Deep black, Metal grey, Moonlight

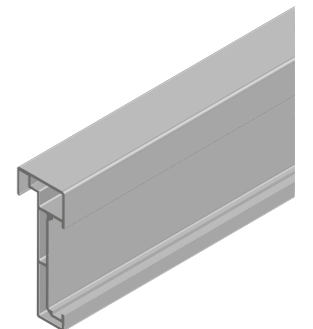
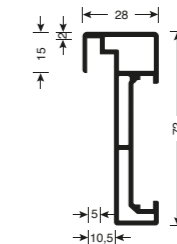

### PS19CS1001

Confezione per montaggio anta.

Finitura: Zincato

Kit for assembly door.

Finish: Zinc plated

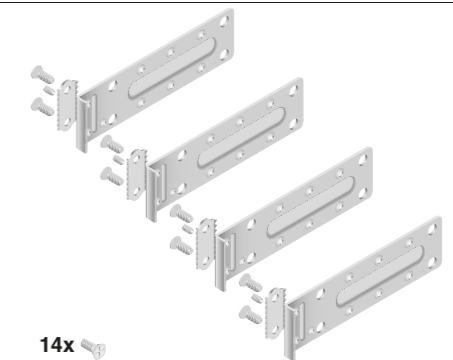

# PS19.1

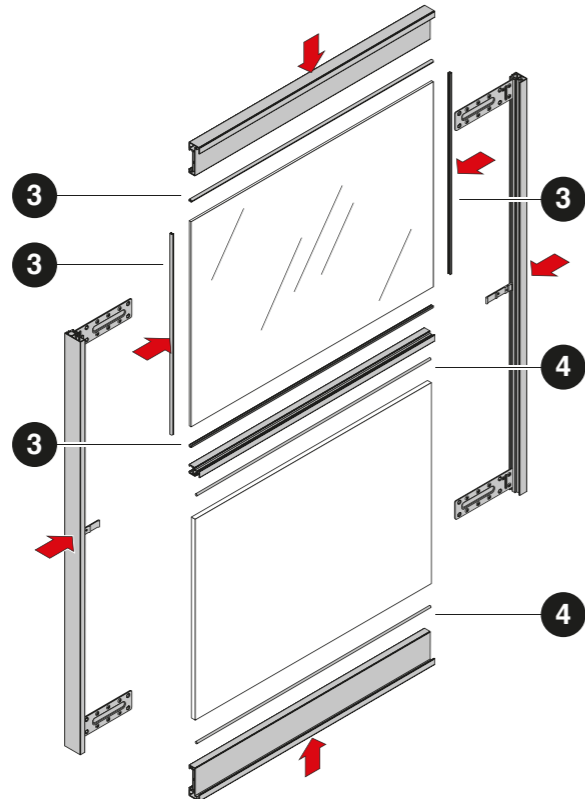
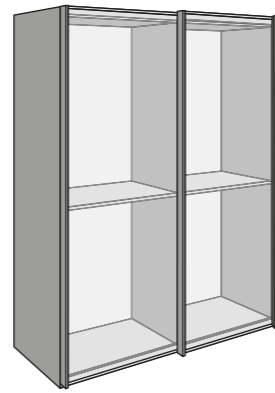
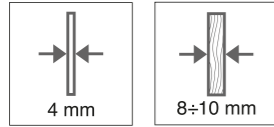

**ABBREVIAZIONI:**  
**WA** = larghezza anta  
**WP** = larghezza pannello  
**WG** = larghezza vetro  
**H1** = altezza anta  
**HP** = altezza pannello  
**HG** = altezza vetro

**ABBREVIATIONS:**  
**WA** = door width  
**WP** = panel width  
**WG** = glass width  
**H1** = door height  
**HP** = panel height  
**HG** = glass height

**PR20820002** Edge 0.8  
**PR20820004** Edge 0.6

Guarnizione per vetro.  
 Finitura: Neutro

Gasket for glass.  
 Finish: Neutral

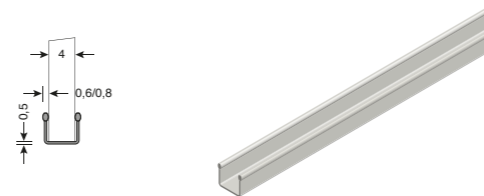

**TE238B0001**  
 Profilo tondo di compensazione Ø3 per pannello da 8 mm.  
 Finitura: Grigio

Round profile of compensation Ø3 for panel 8 mm.  
 Finish: Grey

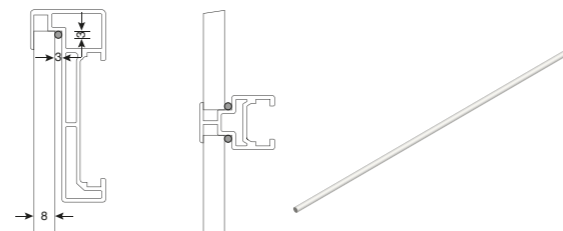

## PS19.1. Schede tecniche / Data sheets

### Calcolo dimensioni vetri e pannelli suddivisi in parti uguali.

Calculation of the dimensions of glasses and wooden panels divided in equal parts.

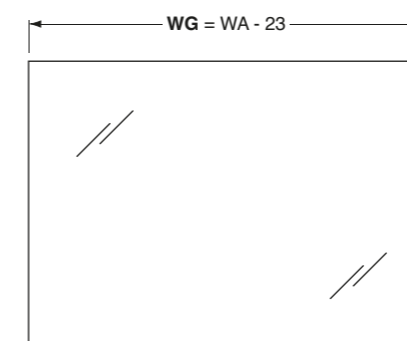
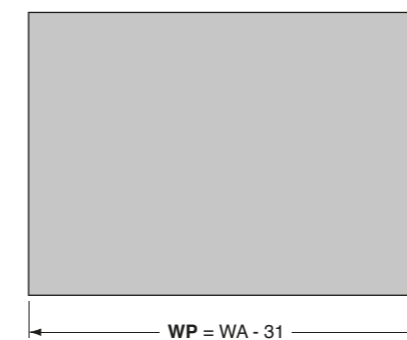
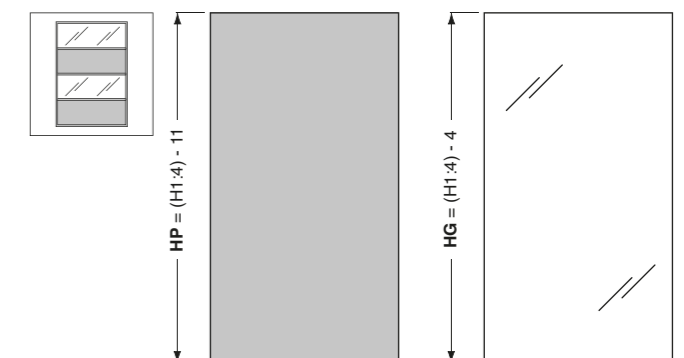
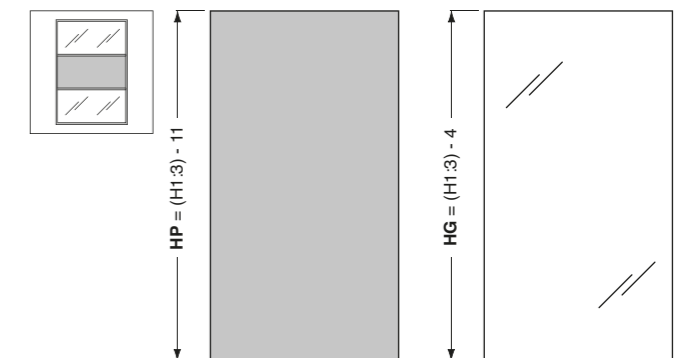
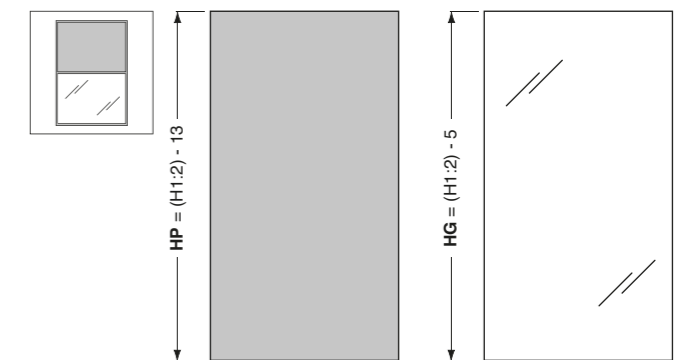
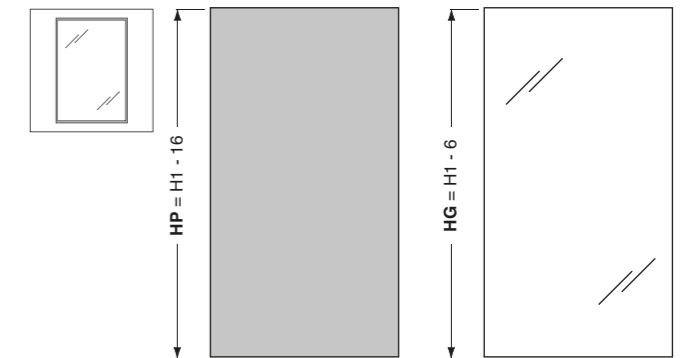
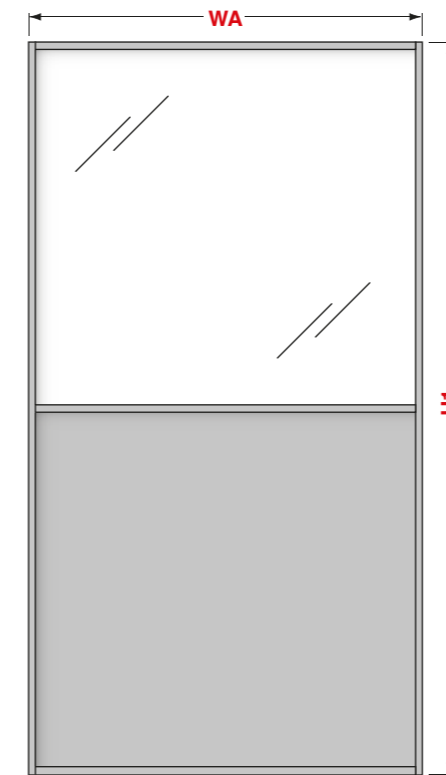



# PS19.1

option  
1

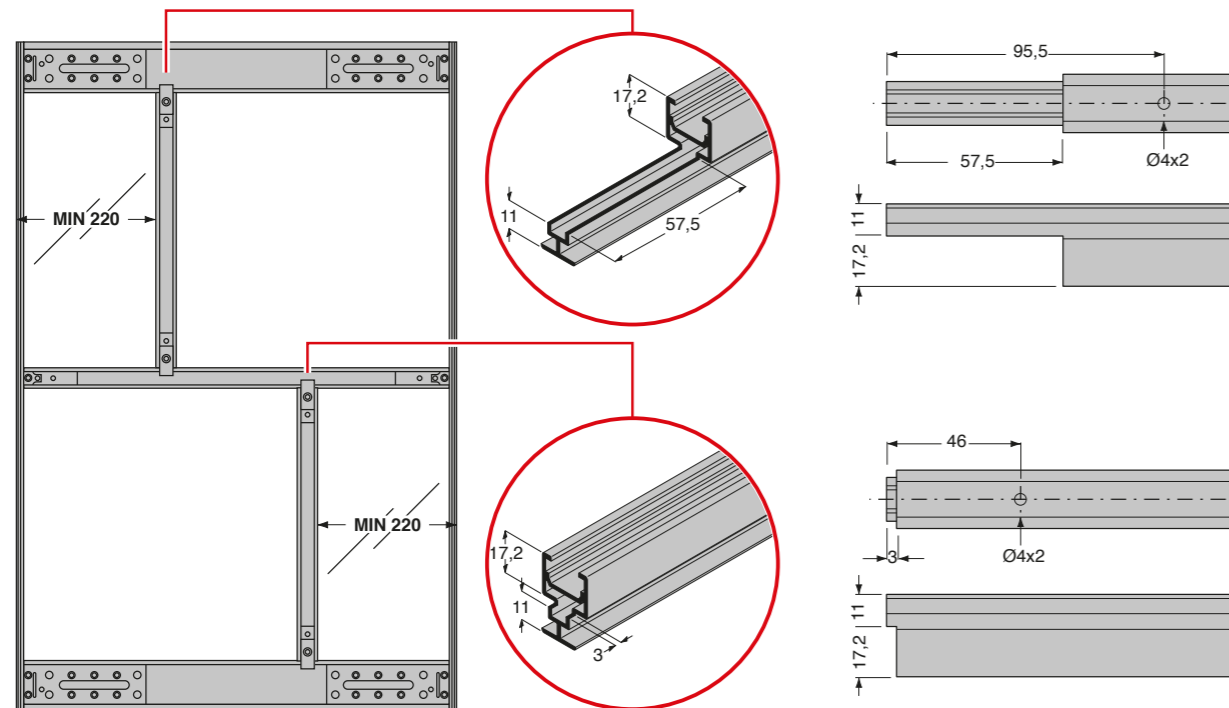
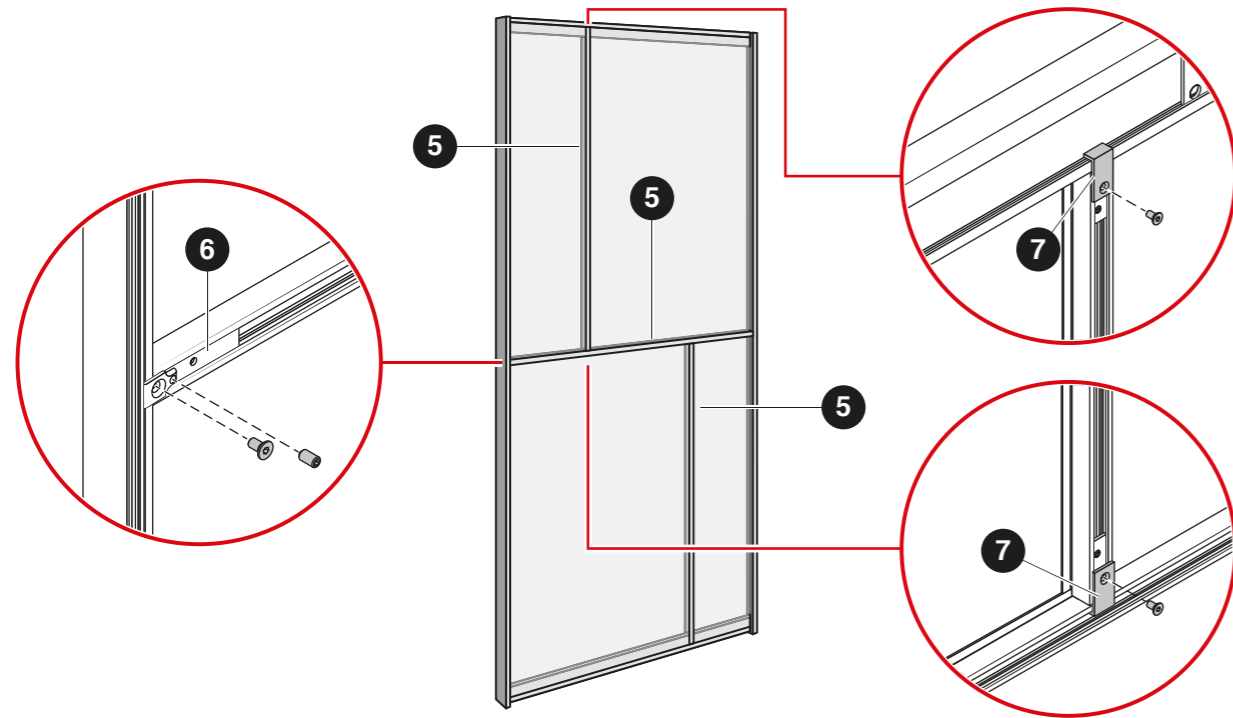

## PS19.1. Lista componenti / Parts list

### PR1970005A

Profilo traversino.

Cross profile.

**Finiture standard / standard finishes**

Anodizzato / anodized: Silver

Verniciato / painted: Deep black, Metal grey, Moonlight

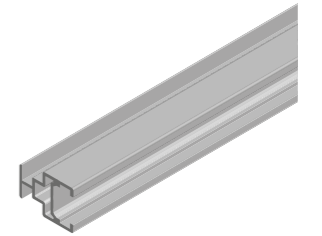
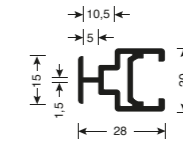

### PS19CS7212

Confezione per montaggio traversino orizzontale.

Finitura: Silver

Kit for assembly horizontal cross profile.

Finish: Silver

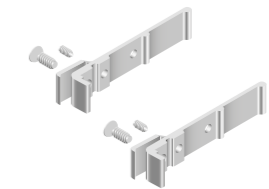

### PS19CS70020016

Confezione per montaggio traversino verticale.

Finitura: Silver

Kit for assembly vertical cross profile.

Finish: Silver

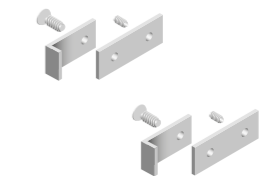

### PR20820002

Edge 0.8

### PR20820004

Edge 0.6

Guarnizione per vetro.

Finitura: Neutro

Gasket for glass.

Finish: Neutral

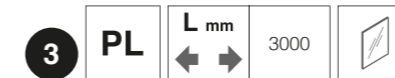
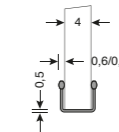

### TE238B0001

Profilo tondo di compensazione Ø3 per pannello da 8 mm.

Finitura: Grigio

Round profile of compensation Ø3 for panel 8 mm.

Finish: Grey

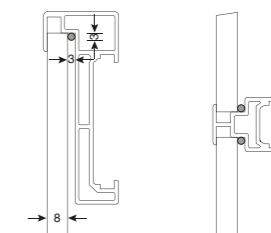

# PS19.1

option  
2

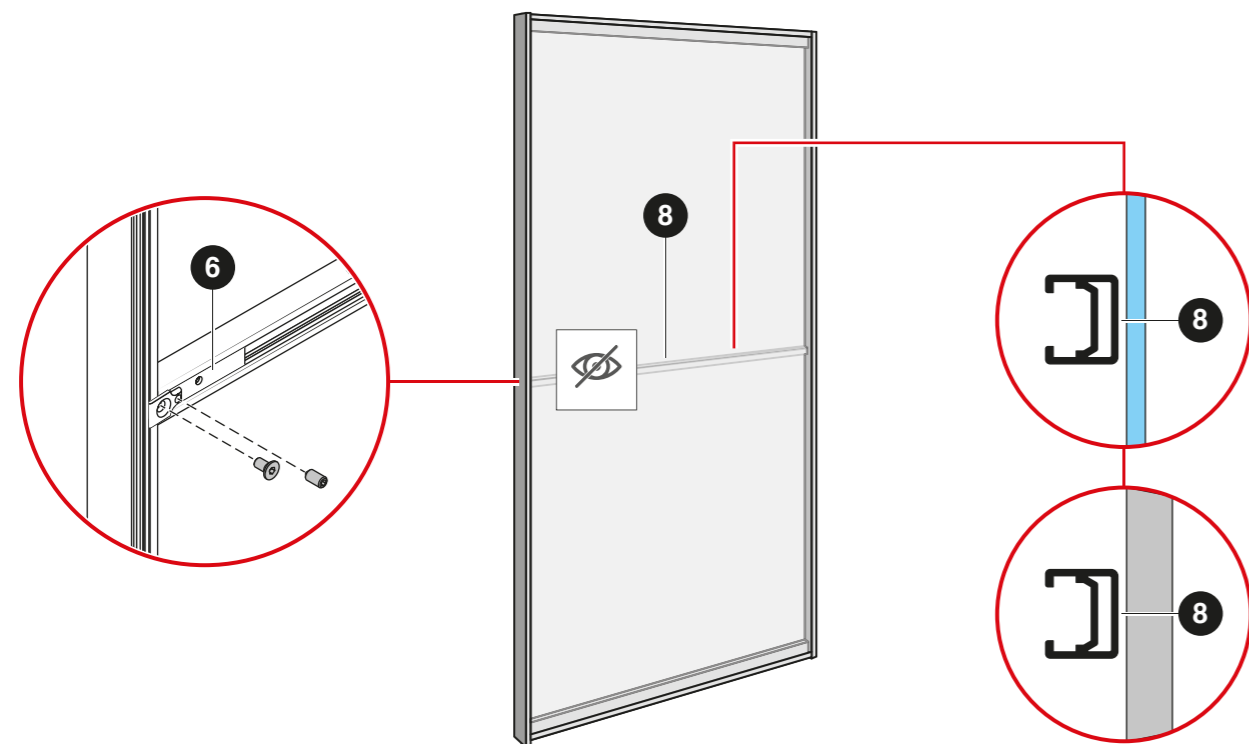
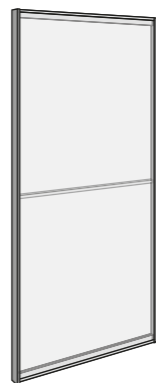

## PR1970021A

Profilo traversino senza sede vetro.

Cross profile without glass gasket seat.

### Finiture standard / standard finishes

Anodizzato / anodized: Silver  
Verniciato / painted: Deep black, Metal grey, Moonlight

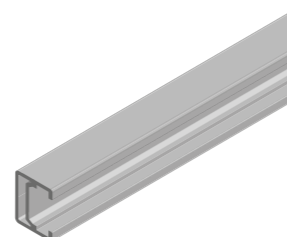
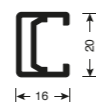
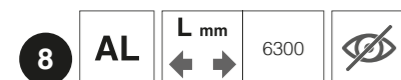

## PS19CS7212

Confezione per montaggio traversino orizzontale.  
Finitura: Silver

Kit for assembly horizontal cross profile.  
Finish: Silver

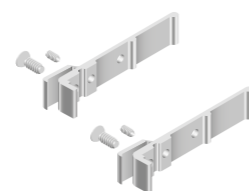

## PS19.1. Lista componenti / Parts list

### Accessori complementari

Additional accessories

#### PZ03480590A

Spazzolino parapolvere.  
Finitura: Nero

Save-dust brush.  
Finish: Black

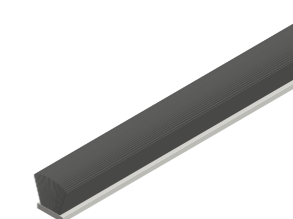
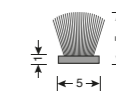

#### BR

Raddrizza ante.

Doors straightener.

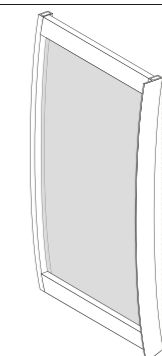

# PS19.2

**PS48**  
compatible

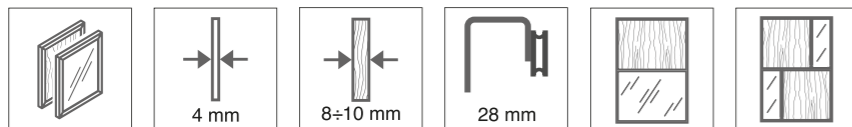
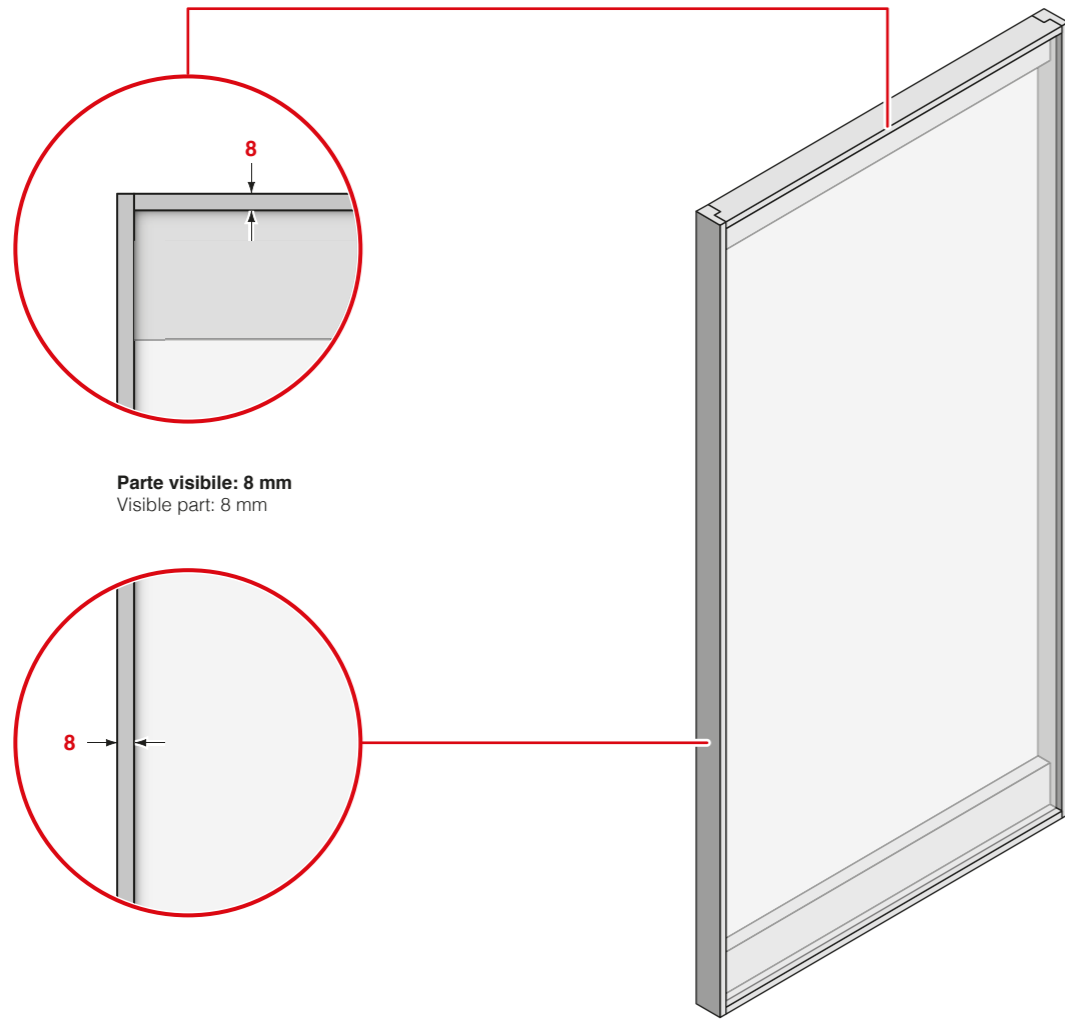
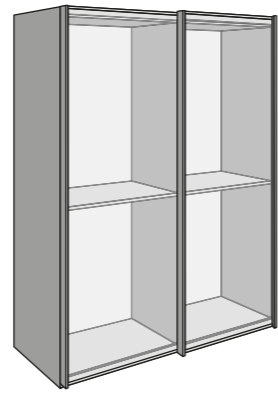

## PS19.2. Schede tecniche / Data sheets

1

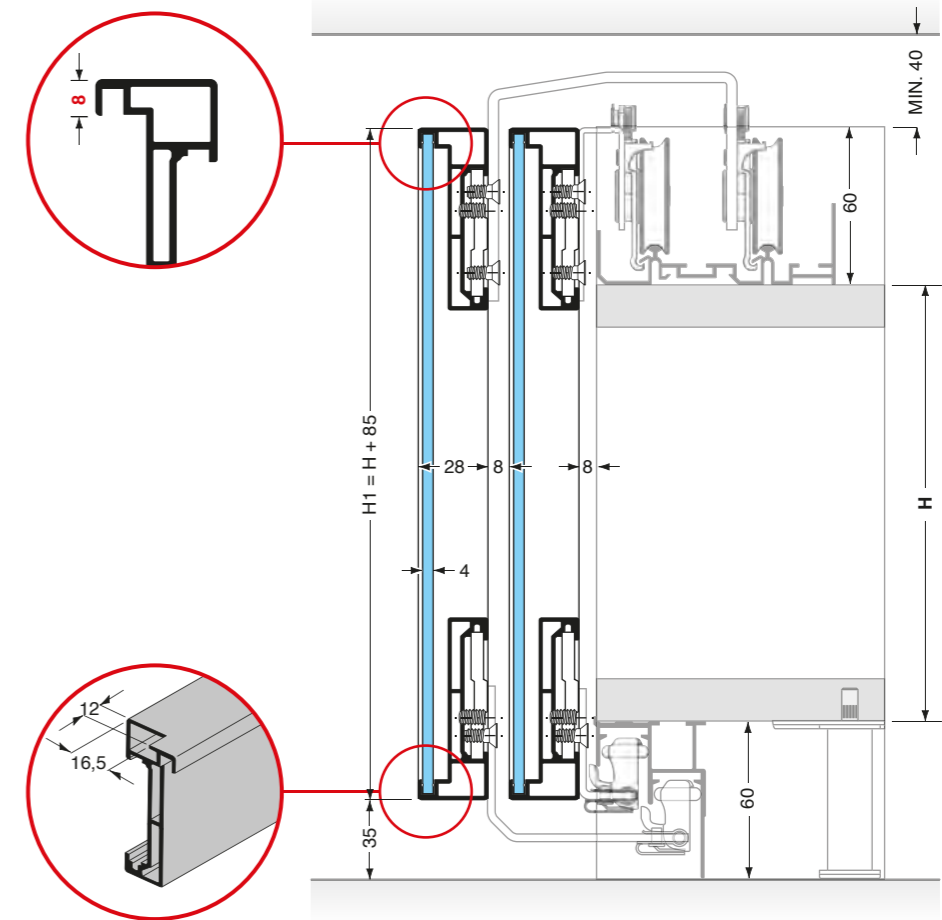

**Pattini compatibili / Compatible slides.**

**PS48AP2E2801**

**PS48AP2E01**

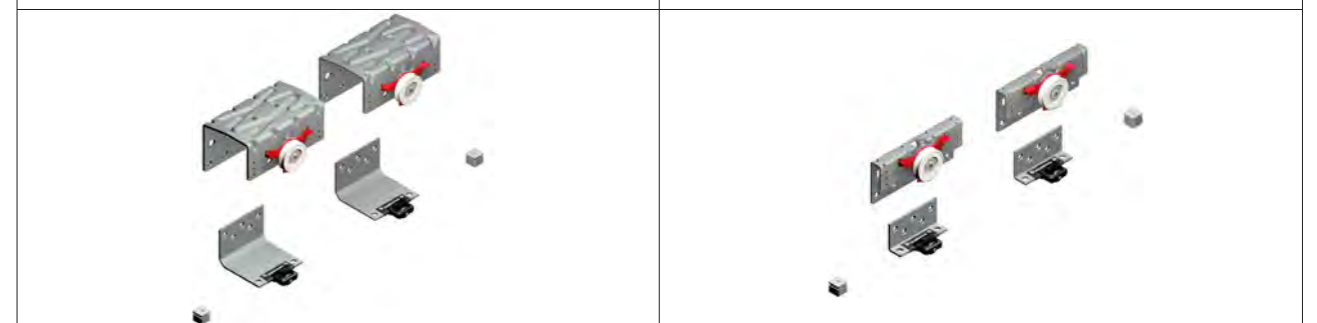

2

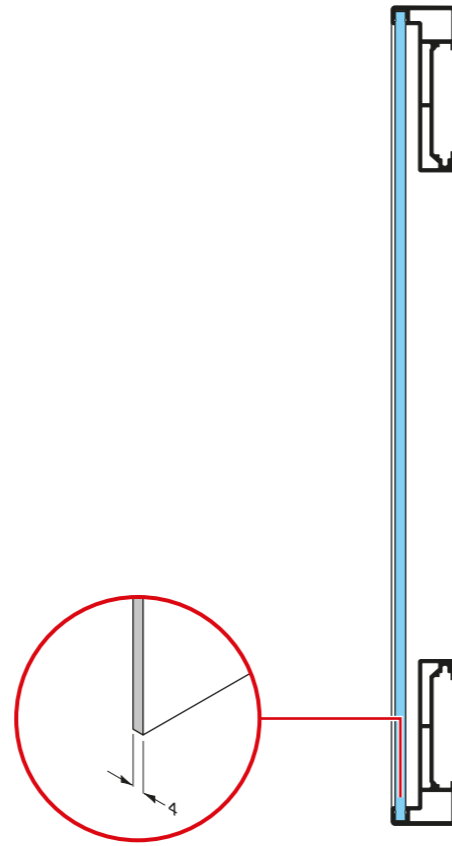

3

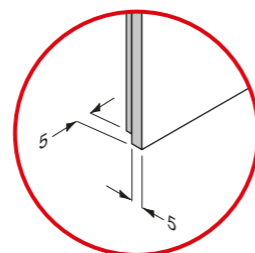
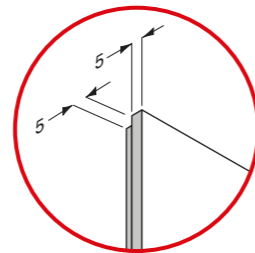
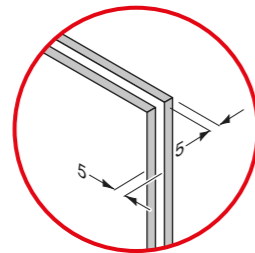
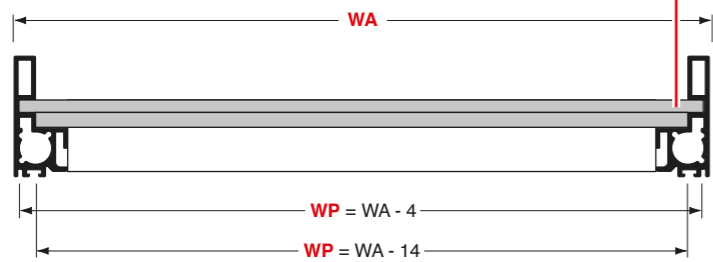

4

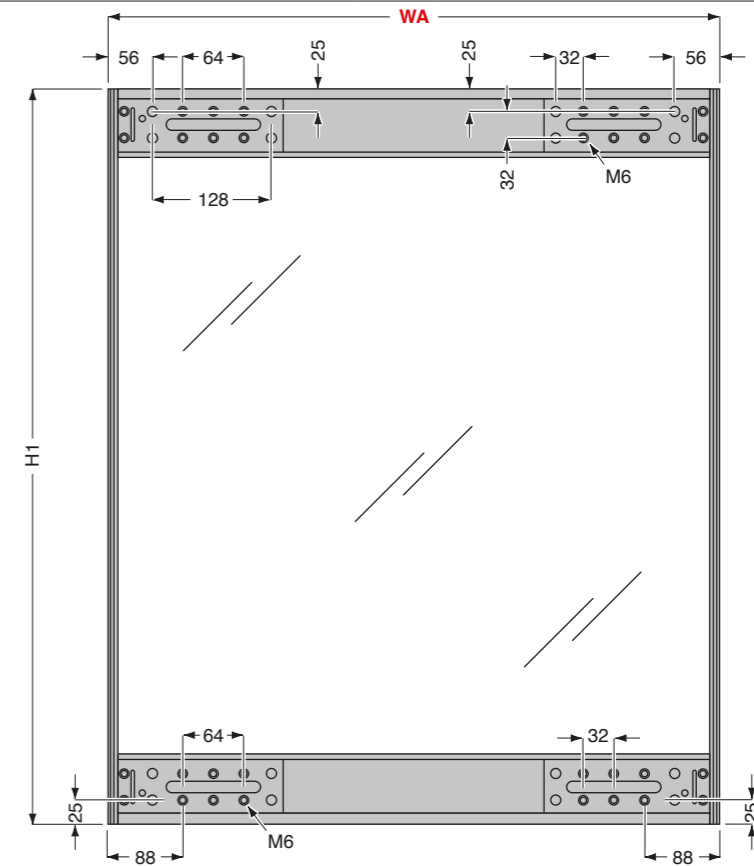

5

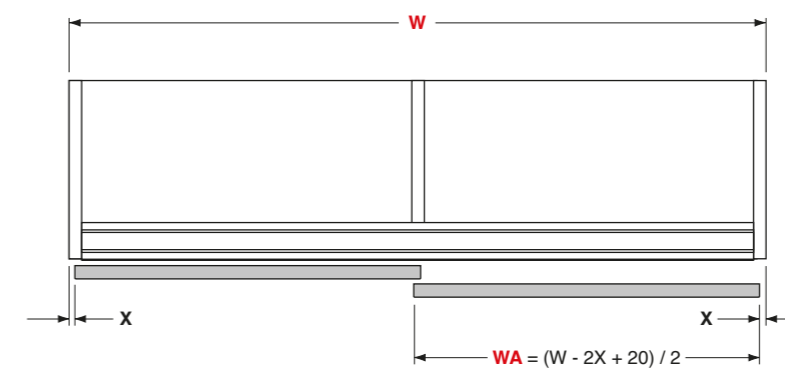

- ABBREVIAZIONI:**  
**W** = larghezza  
**WA** = larghezza anta  
**WP** = larghezza pannello  
**WG** = larghezza vetro
- ABBREVIATIONS:**  
**W** = width  
**WA** = door width  
**WP** = panel width  
**WG** = glass width

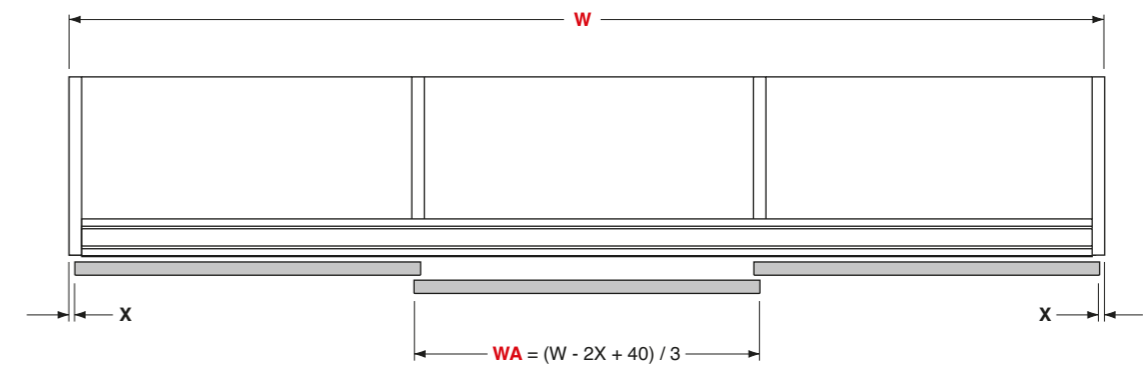

# PS19.2

set  
1

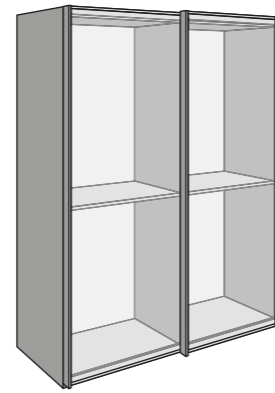

Fianco laterale con recupero  
Long lateral side

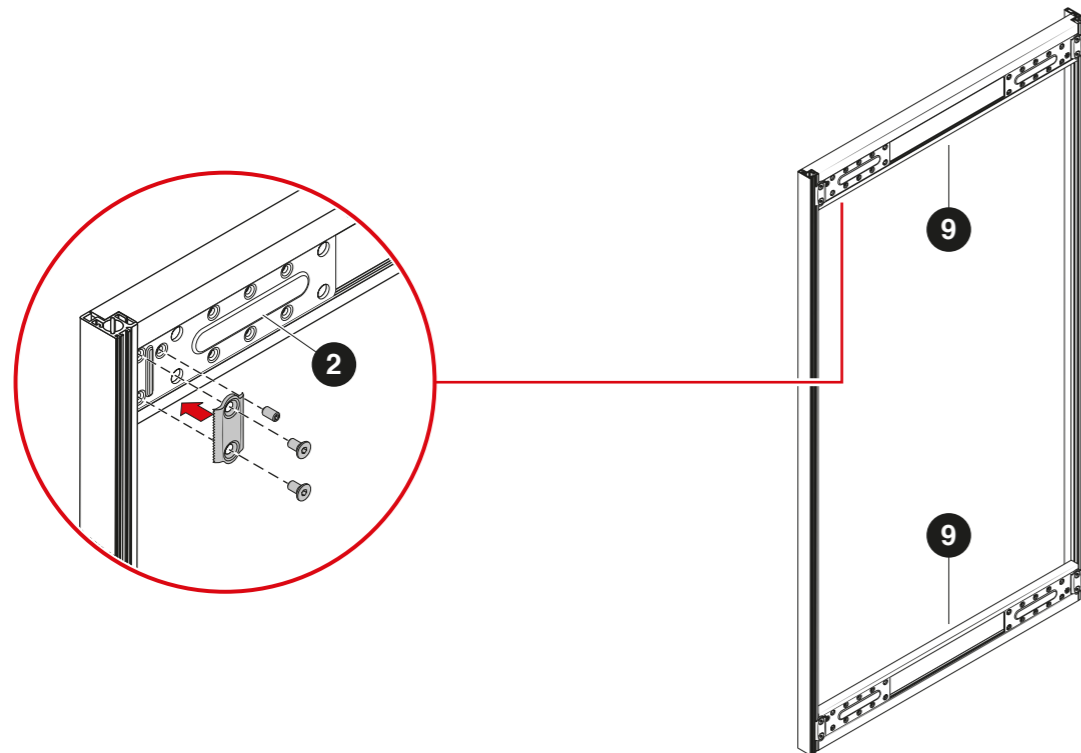
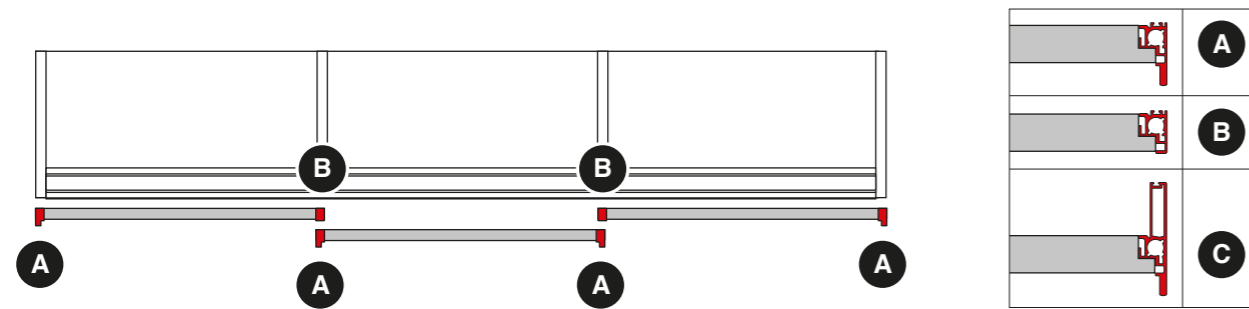
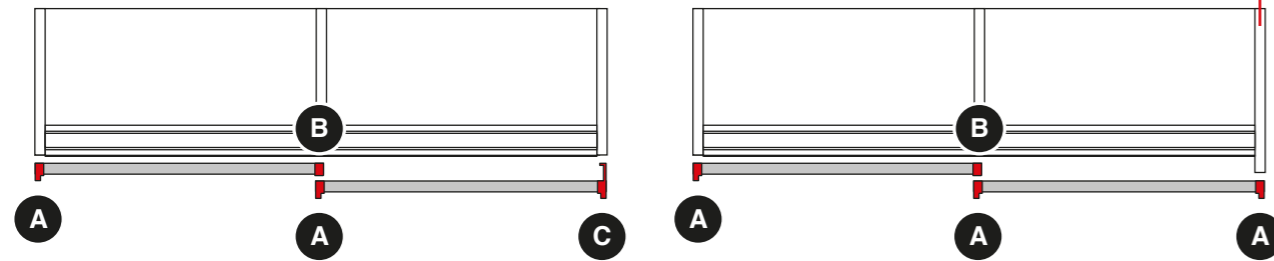

## PS19.2. Lista componenti / Parts list

### PR1970015A

Profilo maniglia bassa.

Narrow handle profile.

Finiture standard / standard finishes  
Anodizzato / anodized: Silver

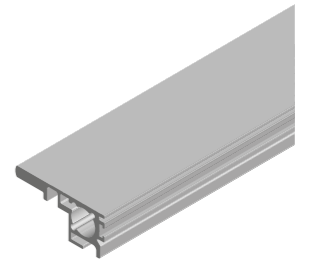
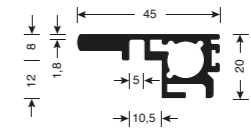

set 1 A AL L mm 5400 6000

### PR1970012A

Profilo montante verticale.

Vertical rod profile.

Finiture standard / standard finishes  
Anodizzato / anodized: Silver

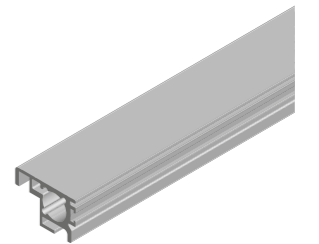
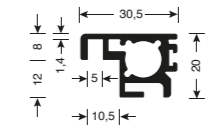

set 1 B AL L mm 5400 6000

### PR1970018A

Profilo maniglia alta.

Wide handle profile.

Finiture standard / standard finishes  
Anodizzato / anodized: Silver

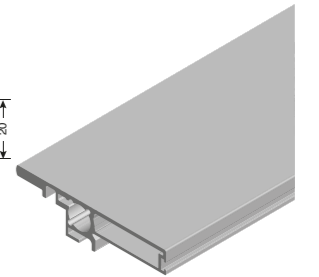
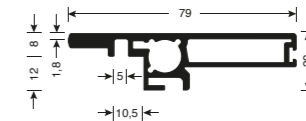

set 1 C AL L mm 5400 6000

### PR1970010A

Profilo traverso superiore - inferiore.

Upper - lower horizontal profile.

Finiture standard / standard finishes  
Anodizzato / anodized: Silver

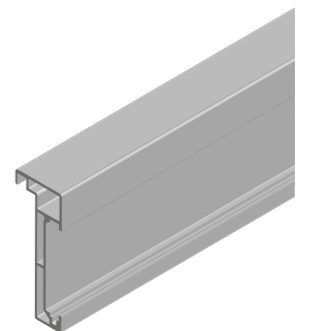
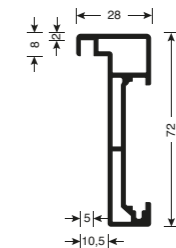

9 AL L mm 6100

### PS19CS1001

Confezione per montaggio anta.  
Finitura: Zincato

Kit for assembly door.  
Finish: Zinc plated

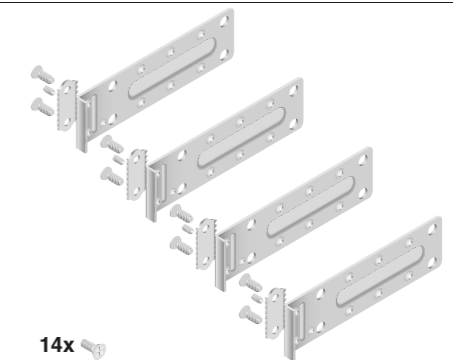

2 FE

# PS19.2

set  
2

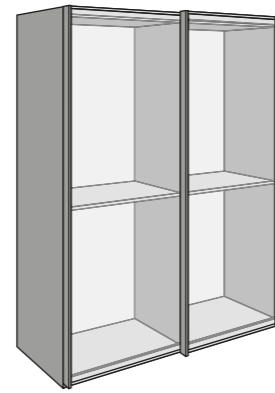

Fianco laterale con recupero  
Long lateral side

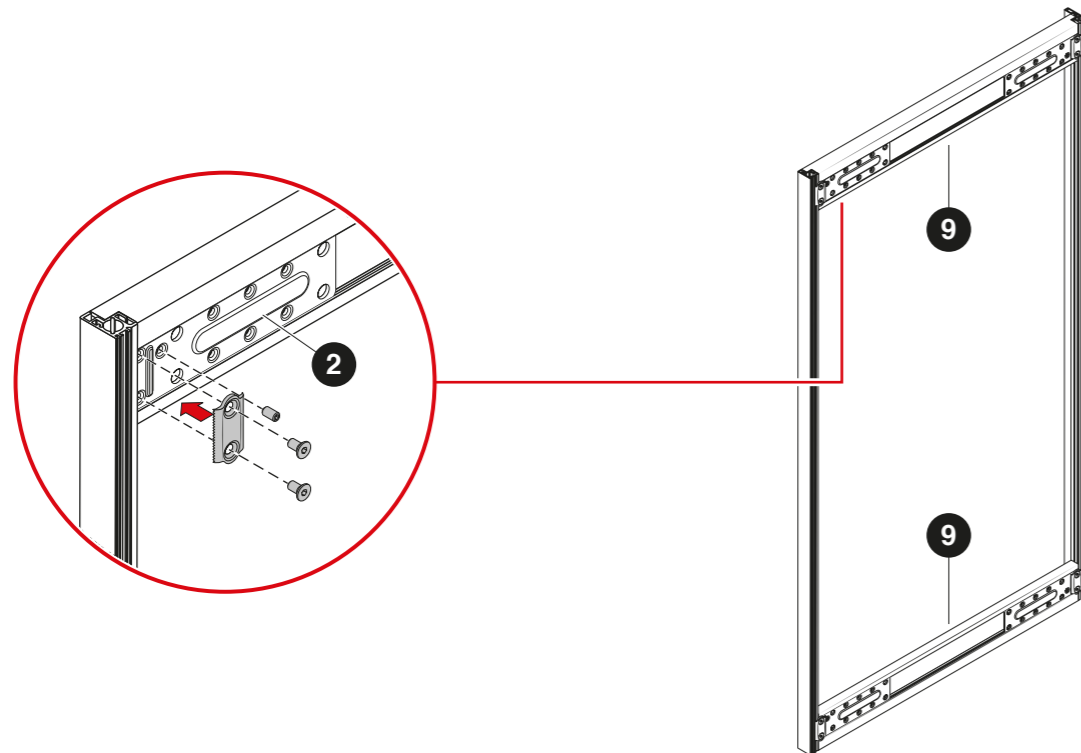
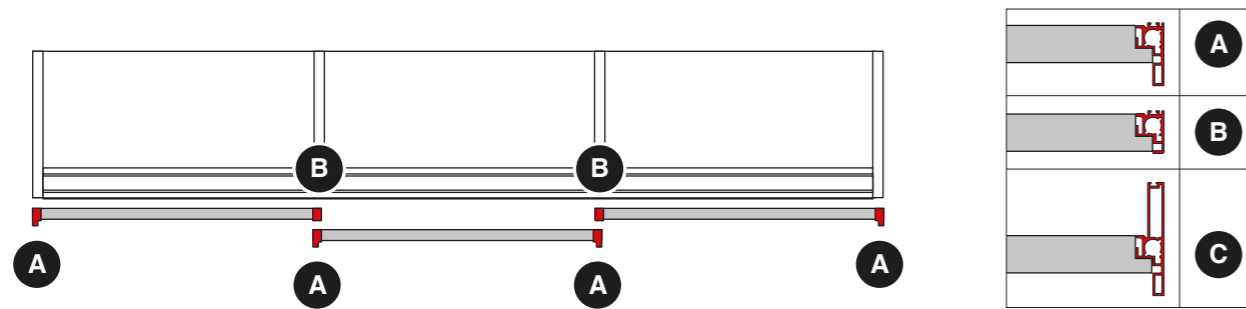
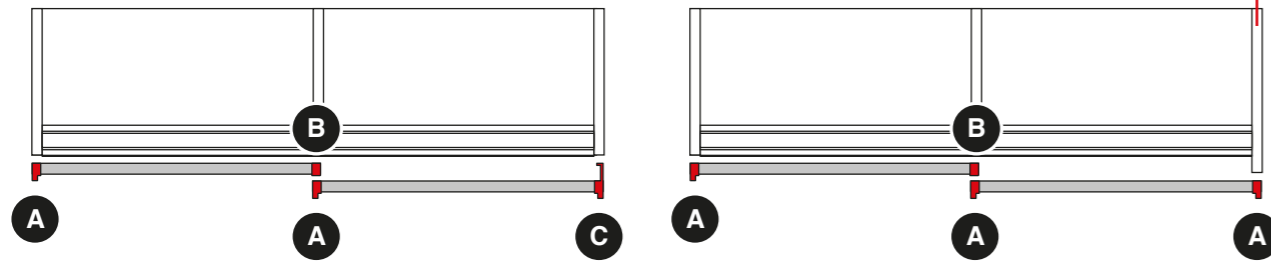

## PS19.2. Lista componenti / Parts list

### PR19700022A

Profilo maniglia bassa.

Narrow handle profile.

**Finiture standard / standard finishes**  
Anodizzato / anodized: Silver

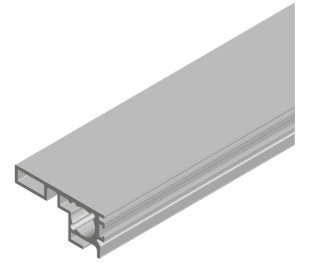
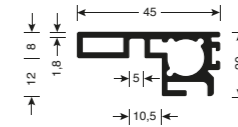

set 2 **A** AL L mm 5300

### PR1970012A

Profilo montante verticale.

Vertical rod profile.

**Finiture standard / standard finishes**  
Anodizzato / anodized: Silver

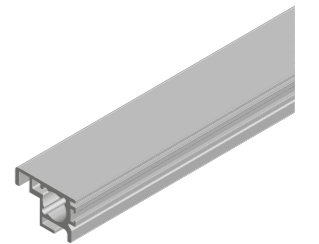
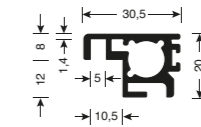

set 2 **B** AL L mm 5400  
6000

### PR197000028A

Profilo maniglia alta.

Wide handle profile.

**Finiture standard / standard finishes**  
Anodizzato / anodized: Silver

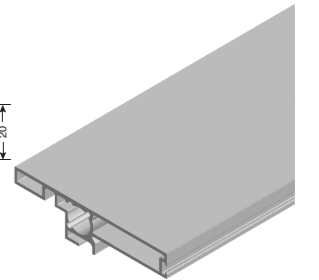
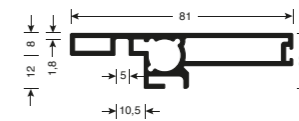

set 2 **C** AL L mm 5300

### PR1970010A

Profilo traverso superiore - inferiore.

Upper - lower horizontal profile.

**Finiture standard / standard finishes**  
Anodizzato / anodized: Silver

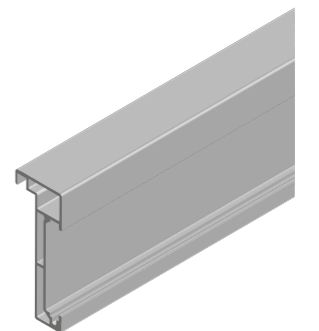
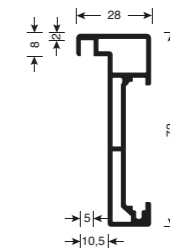

9 AL L mm 6100

### PS19CS1001

Confezione per montaggio anta.  
Finitura: Zincato

Kit for assembly door.  
Finish: Zinc plated

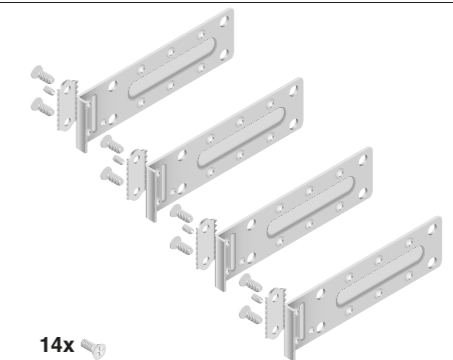

2 FE

# PS19.2

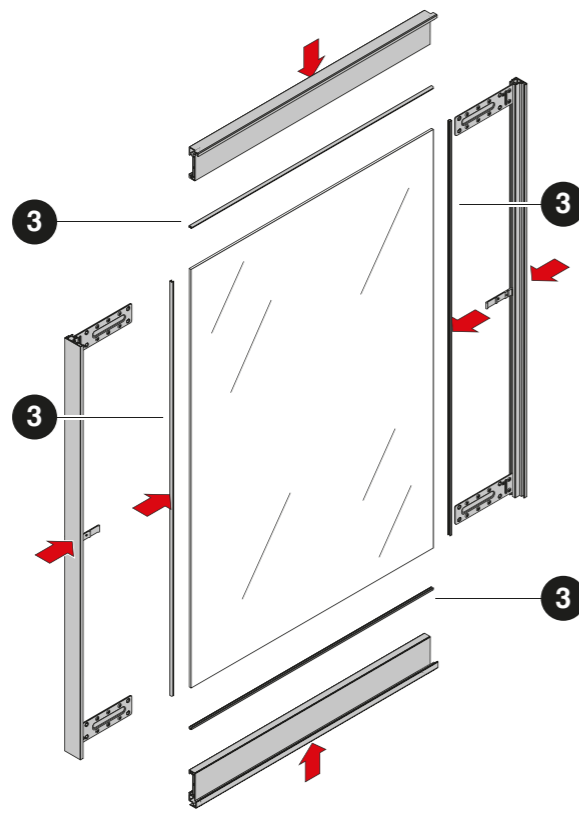
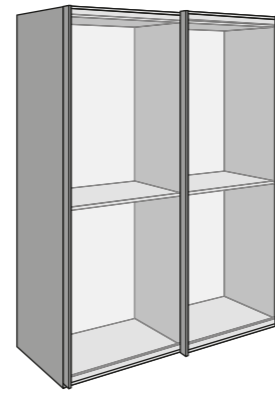

**ABBREVIAZIONI:**  
**WA** = larghezza anta  
**WP** = larghezza pannello  
**WG** = larghezza vetro  
**H1** = altezza anta  
**HP** = altezza pannello  
**HG** = altezza vetro

**ABBREVIATIONS:**  
**WA** = door width  
**WP** = panel width  
**WG** = glass width  
**H1** = door height  
**HP** = panel height  
**HG** = glass height

**PR20820002** Edge 0.8  
**PR20820004** Edge 0.6

Guarnizione per vetro.  
 Finitura: Neutro

Gasket for glass.  
 Finish: Neutral

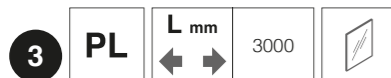
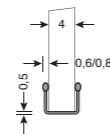

## PS19.2. Schede tecniche / Data sheets

### Calcolo dimensioni vetri e pannelli suddivisi in parti uguali.

Calculation of the dimensions of glasses and wooden panels divided in equal parts.

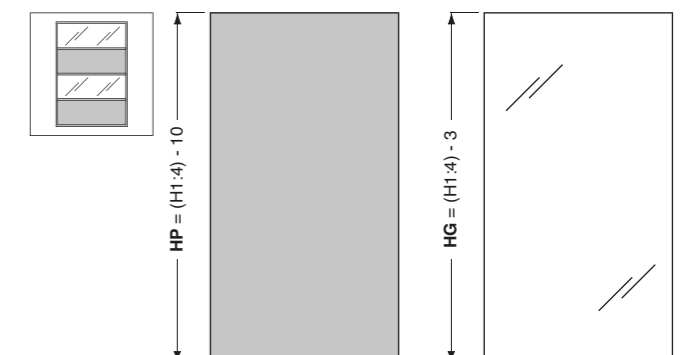
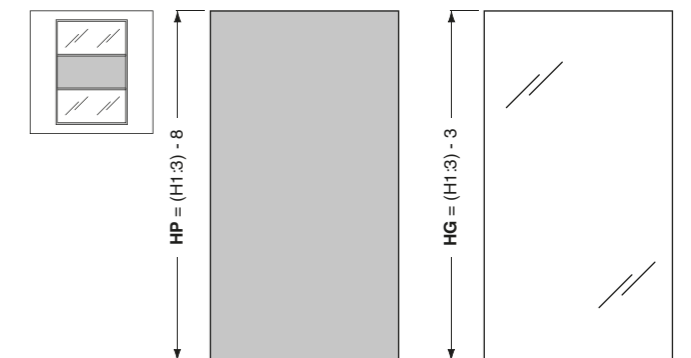
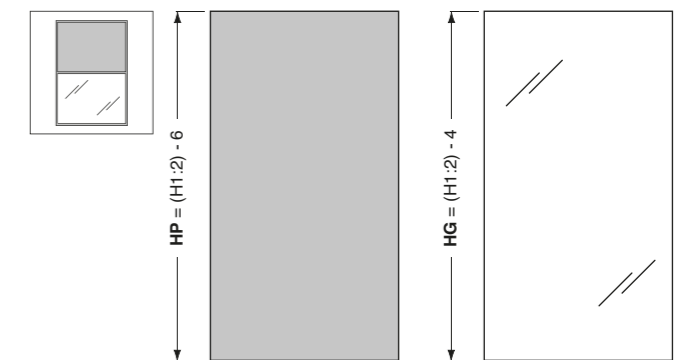
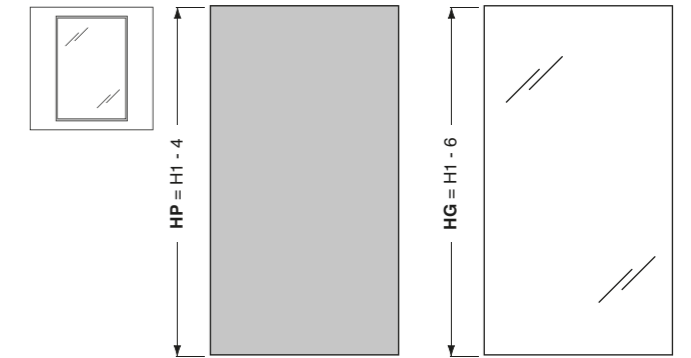
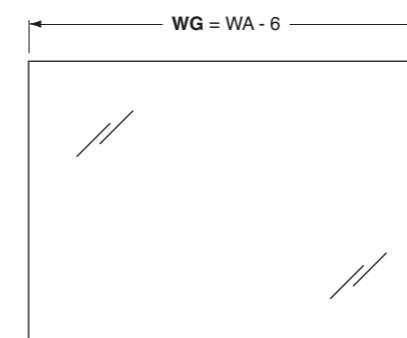
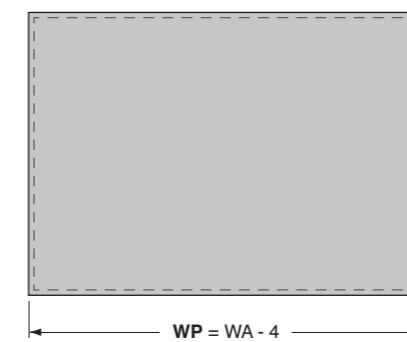
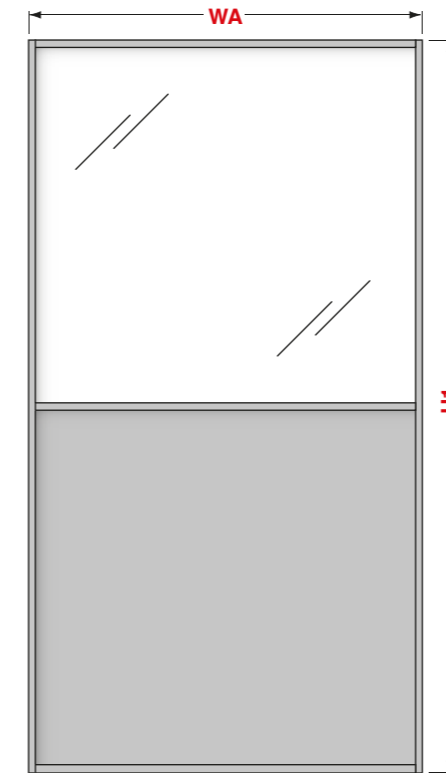

# PS19.2

option  
1

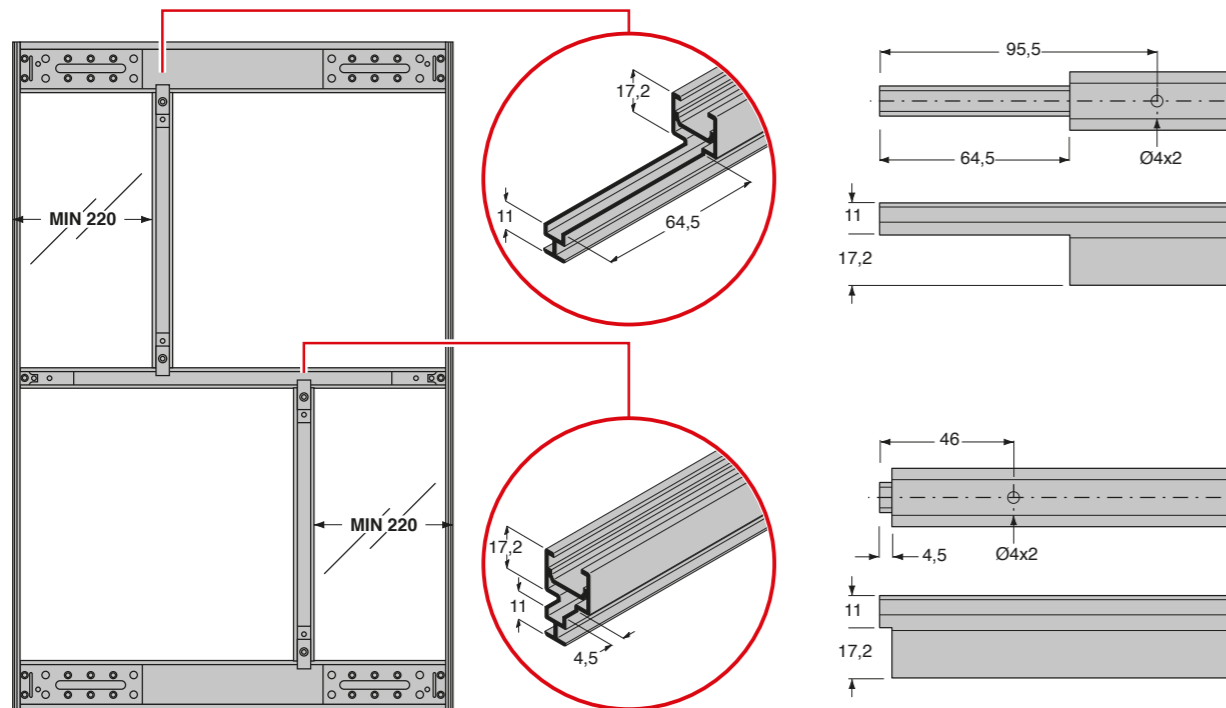
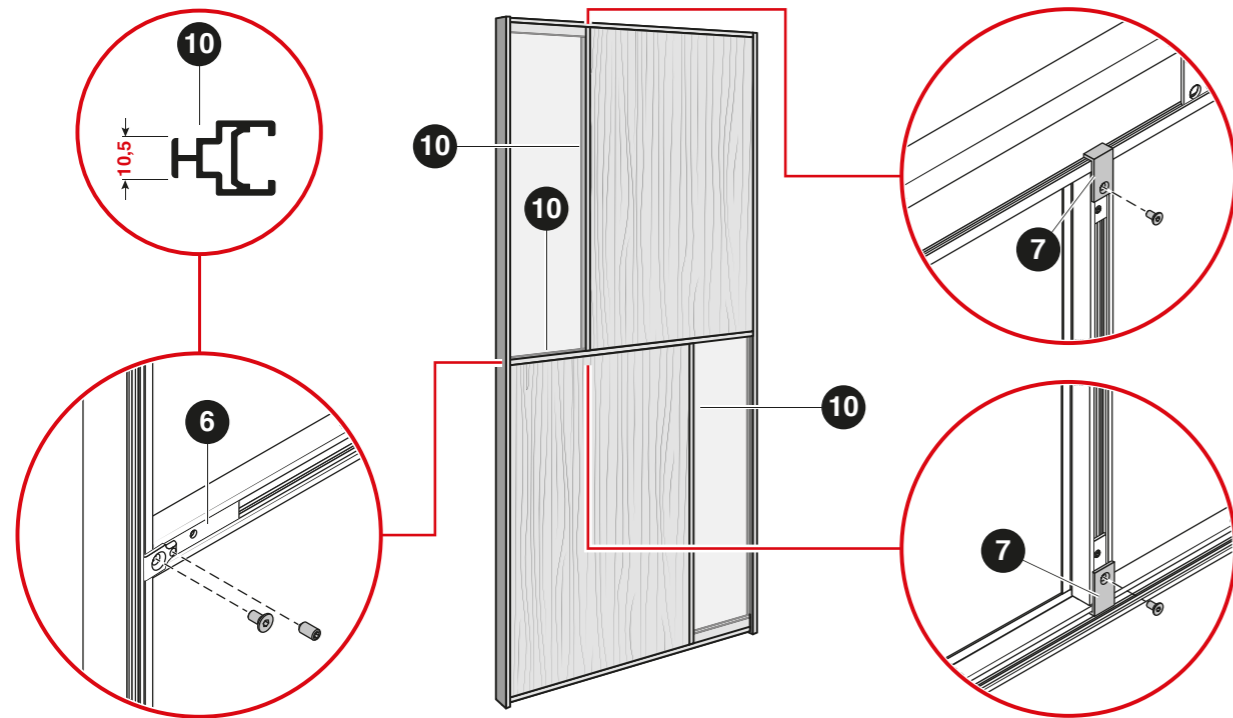

## PS19.2. Lista componenti / Parts list

### PR1970011A

Profilo traversino.

Cross profile.

**Finiture standard / standard finishes**  
Anodizzato / anodized: Silver

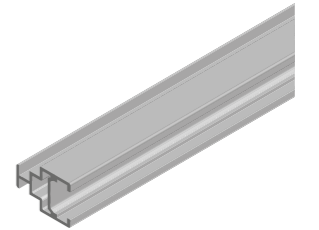
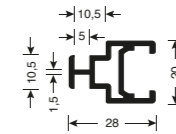

10 AL L mm 6100

### PS19CS7212

Confezione per montaggio traversino orizzontale.  
Finitura: Silver

Kit for assembly horizontal cross profile.  
Finish: Silver

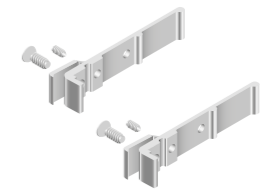

6 AL

### PS19CS70020016

Confezione per montaggio traversino verticale.  
Finitura: Silver

Kit for assembly vertical cross profile.  
Finish: Silver

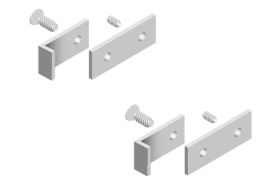

7 AL

### PR20820002 Edge 0.8

### PR20820004 Edge 0.6

Guarnizione per vetro.  
Finitura: Neutro

Gasket for glass.  
Finish: Neutral

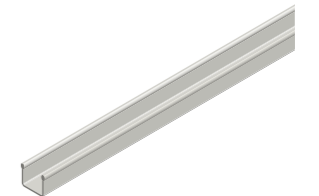
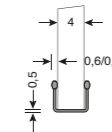

3 PL L mm 3000

### TE238B0001

Profilo tondo di compensazione Ø3 per pannello da 8 mm.  
Finitura: Grigio

Round profile of compensation Ø3 for panel 8 mm.  
Finish: Grey

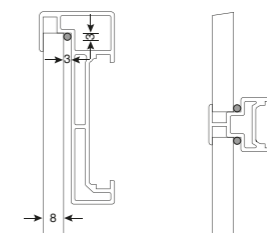

4 PL 8 mm



# PS19.2

option  
2

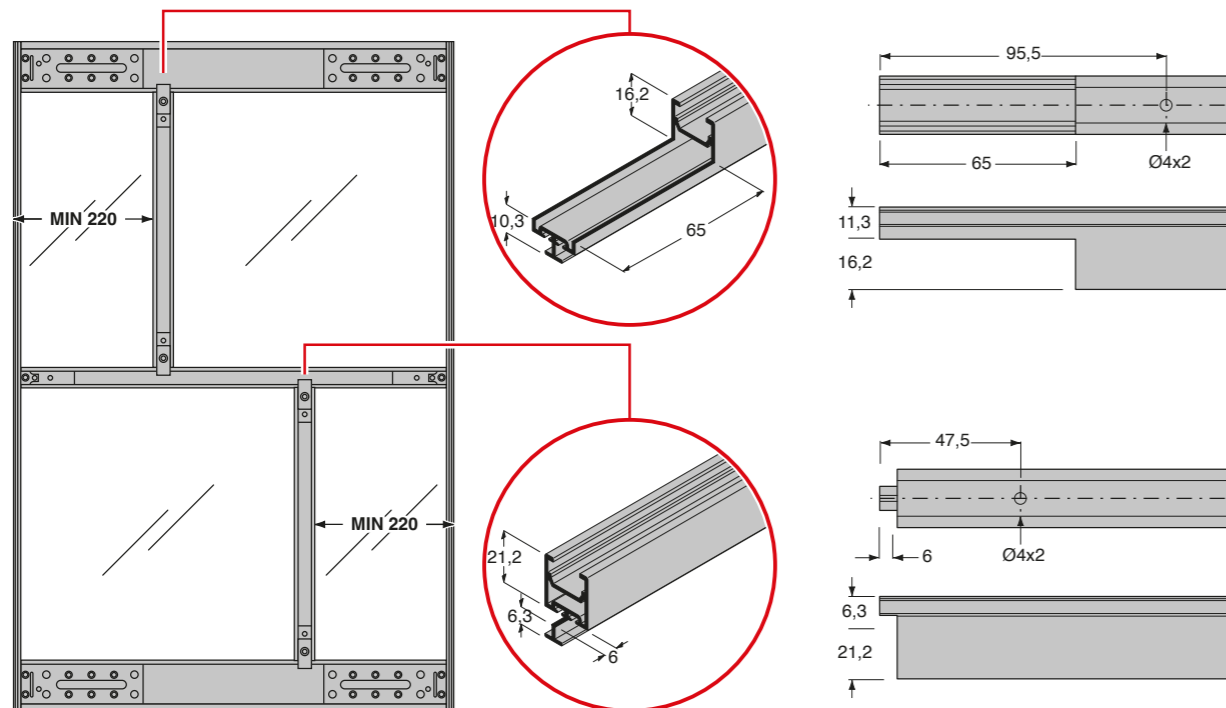
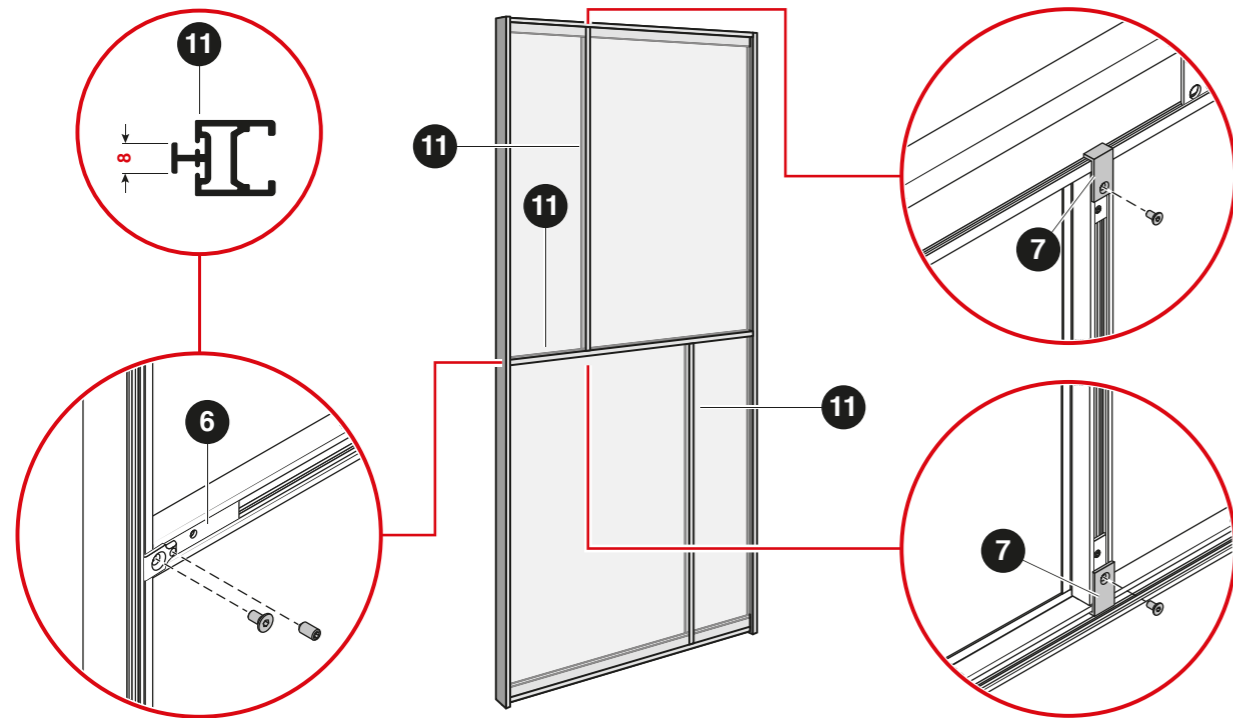

## PS19.2. Lista componenti / Parts list

### PR19700024A

Profilo traversino.

Cross profile.

Finiture standard / standard finishes  
Anodizzato / anodized: Silver

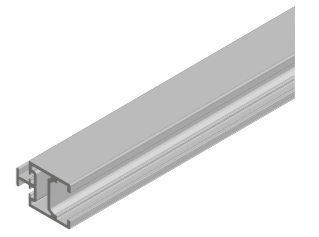
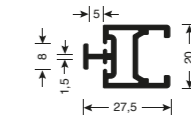

11	AL	L mm	5300
		↔	6300

### PR20810001

Guarnizione per vetro.  
Finitura: Trasparente

Gasket for glass.  
Finish: Transparent

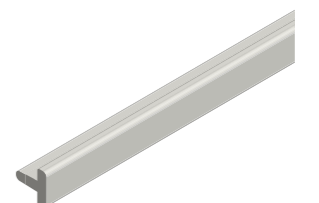
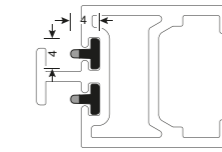

PL	↔	L mm	3000

### PS19CS7212

Confezione per montaggio traversino orizzontale.  
Finitura: Silver

Kit for assembly horizontal cross profile.  
Finish: Silver

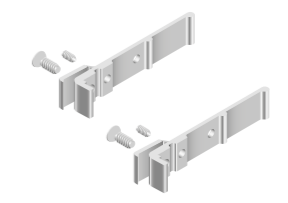

6	AL
---	----

### PS19CS70020016

Confezione per montaggio traversino verticale.  
Finitura: Silver

Kit for assembly vertical cross profile.  
Finish: Silver

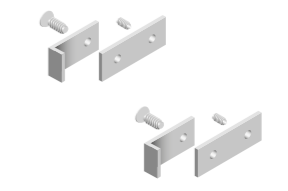

7	AL
---	----

# PS19.2

option  
3

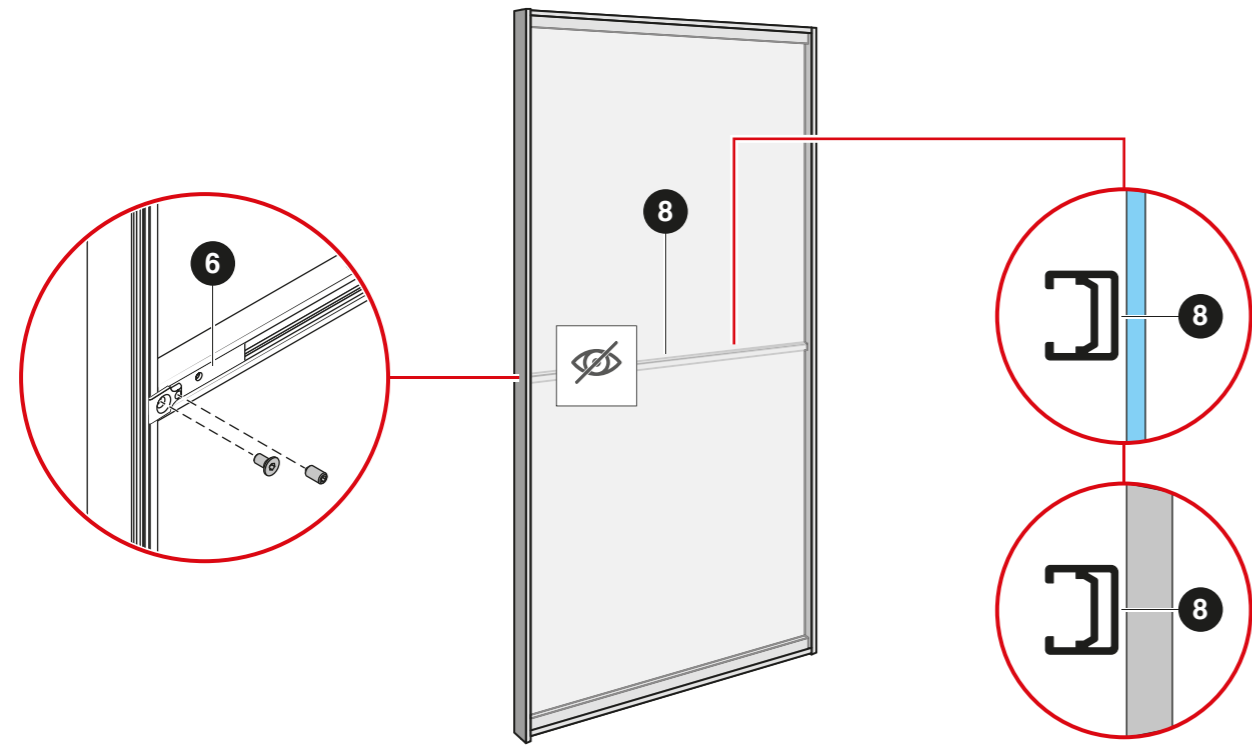
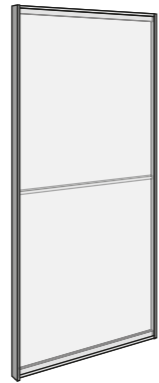

## PR1970021A

Profilo traversino senza sede vetro.

Cross profile without glass gasket seat.

### Finiture standard / standard finishes

Anodizzato / anodized: Silver  
Verniciato / painted: Deep black, Metal grey, Moonlight

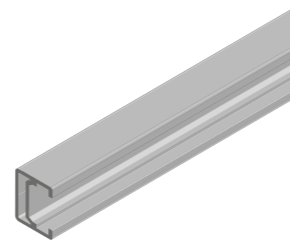
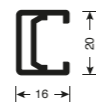

## PS19CS7212

Confezione per montaggio traversino orizzontale.

Finitura: Silver

Kit for assembly horizontal cross profile.

Finish: Silver

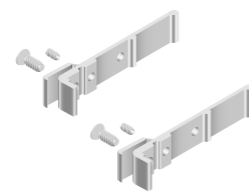

## PS19.2. Lista componenti / Parts list

### Accessori complementari Additional accessories

#### PZ03480590A

Spazzolino parapolvere.  
Finitura: Nero

Save-dust brush.  
Finish: Black

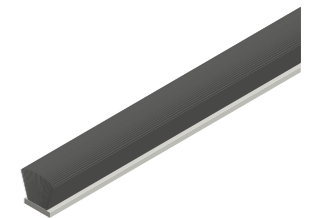
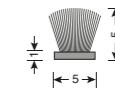

PL

#### BR

Raddrizza ante.

Doors straightener.



# PS19.3

**PS48**  
compatible

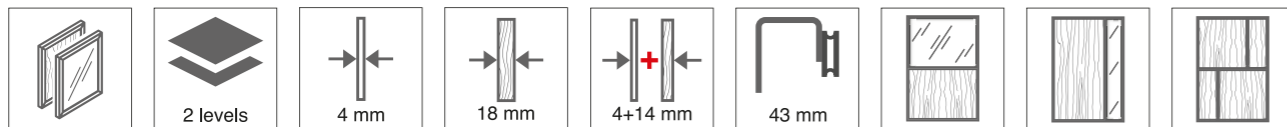
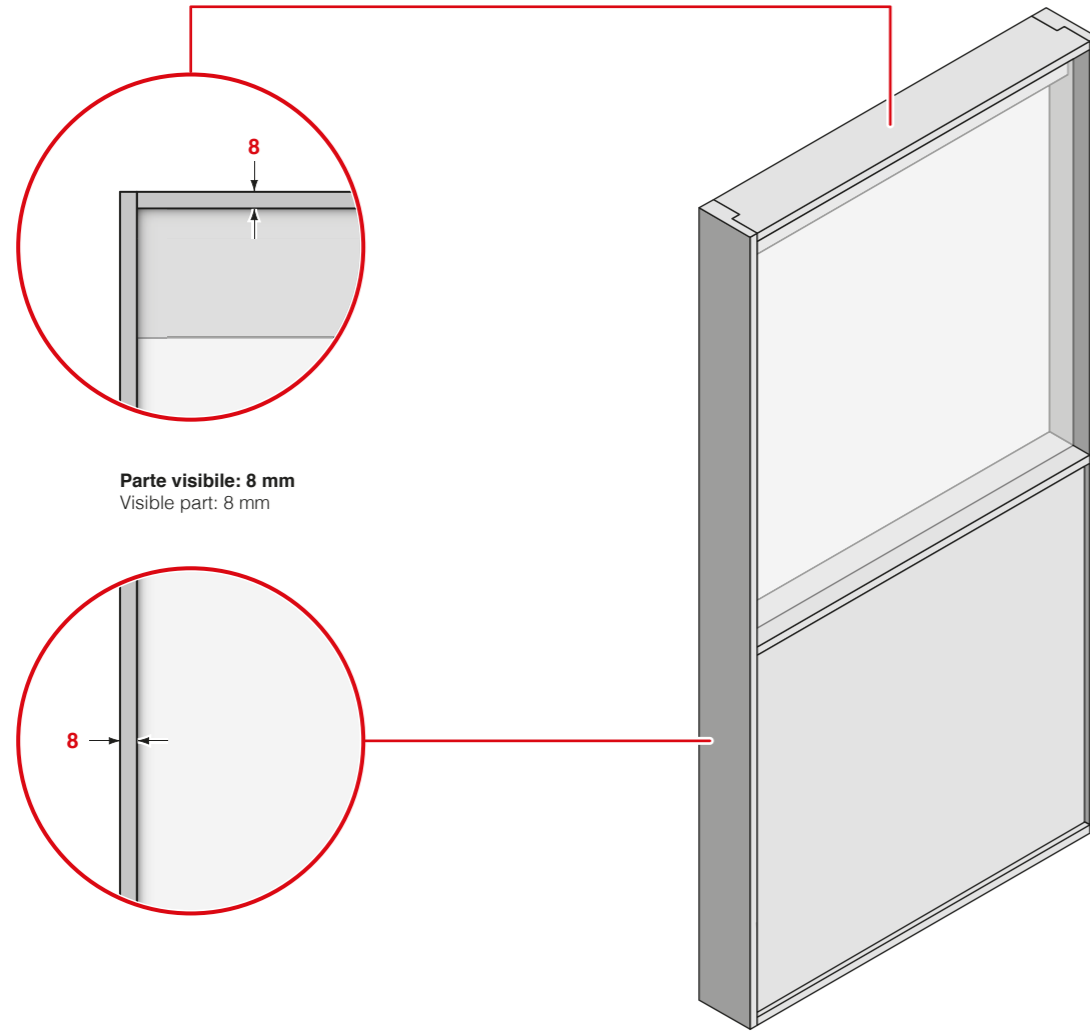
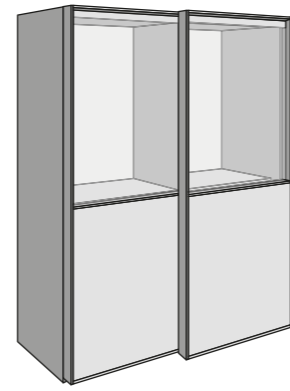

## PS19.3. Schede tecniche / Data sheets

1

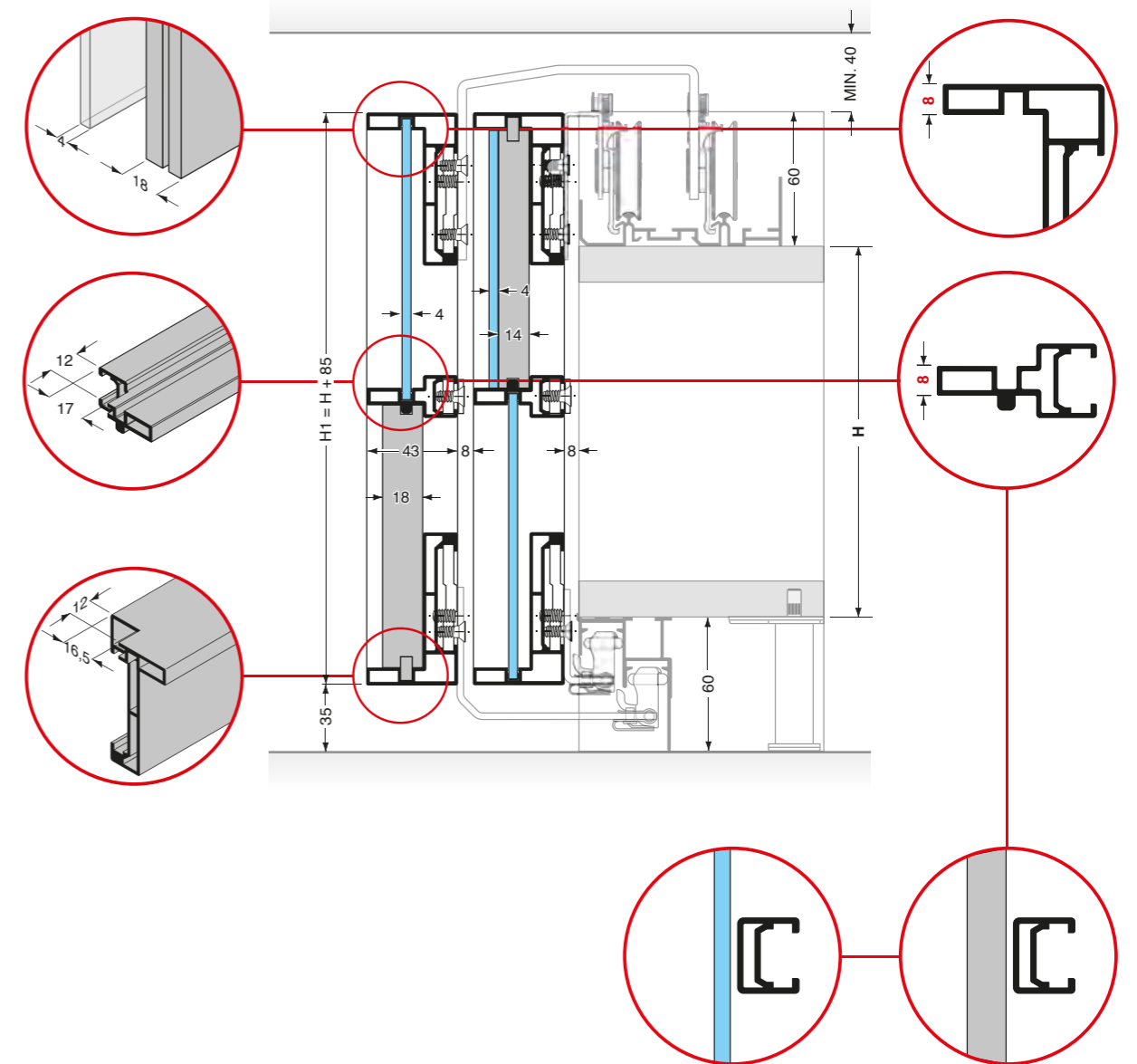

Pattini compatibili / Compatible slides.	
PS48AP2E4301	PS48AP2E01

2

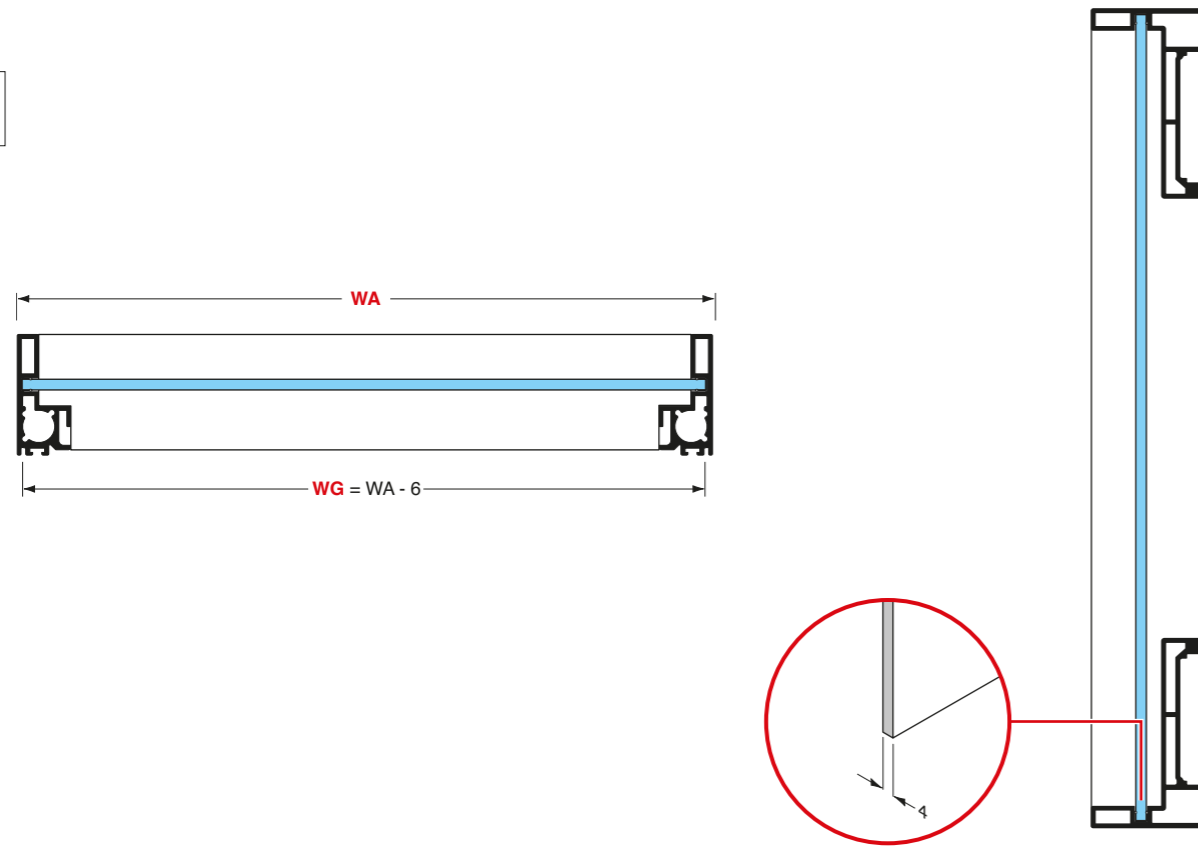

3

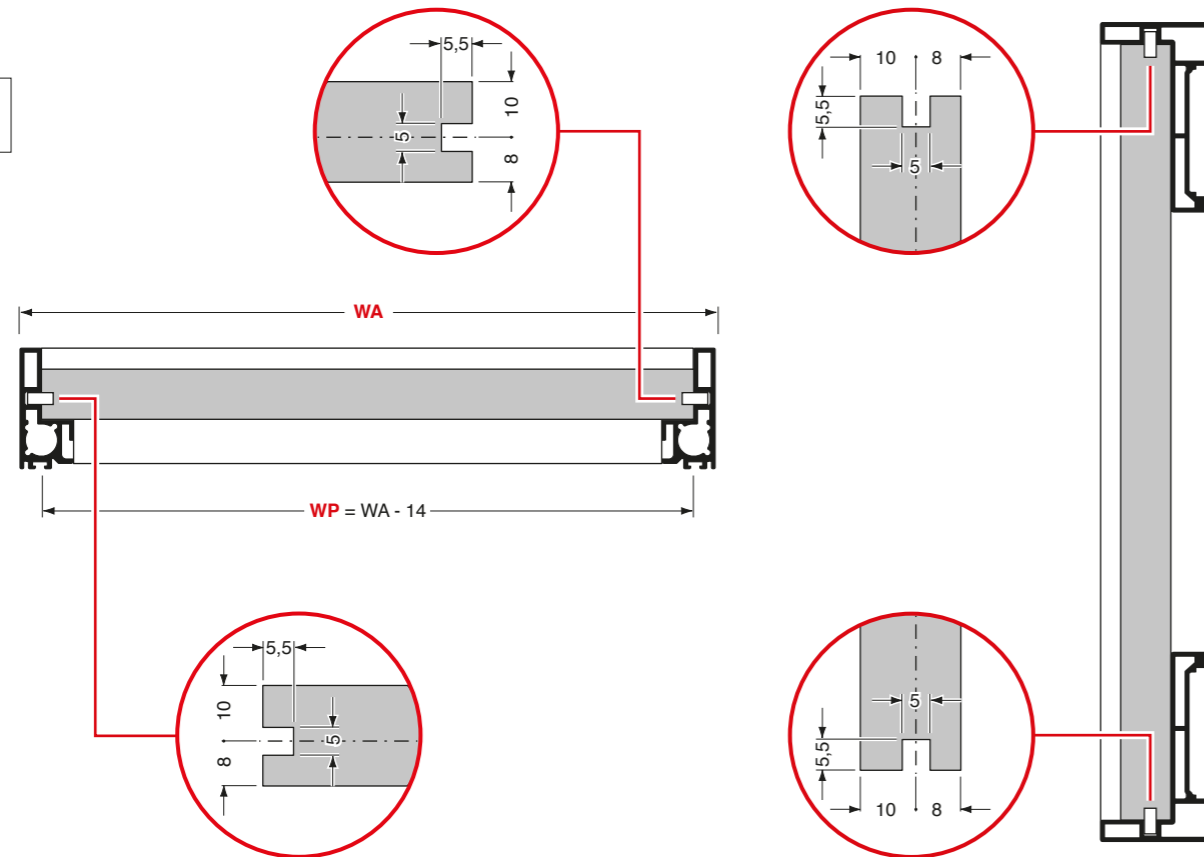

4

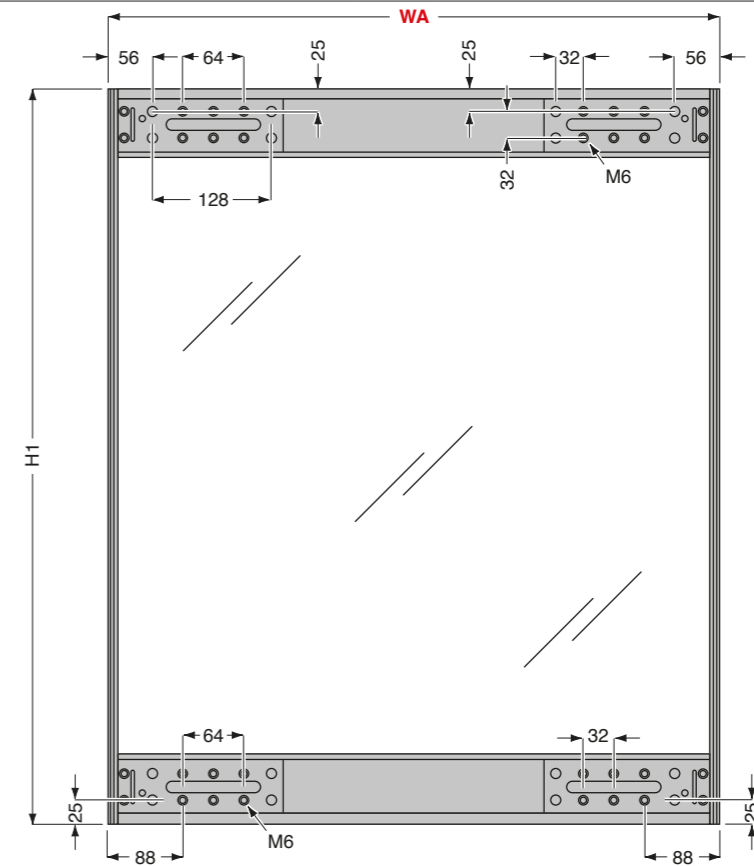

5

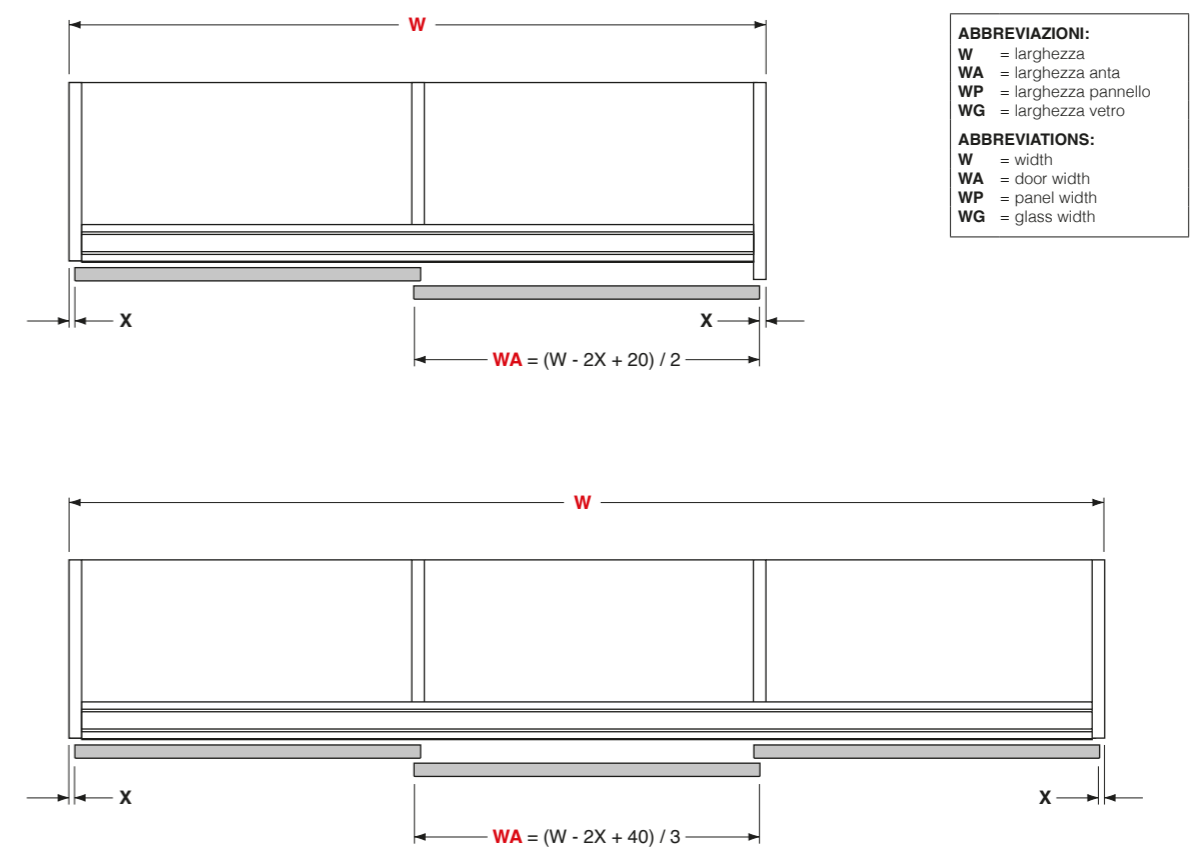

# PS19.3

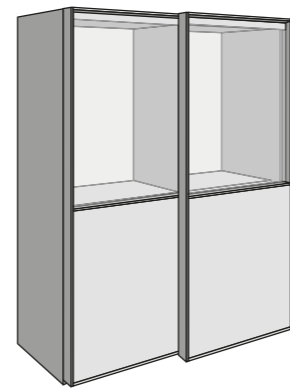

## PS19.3. Lista componenti / Parts list

### PR19700022A

Profilo maniglia bassa.

Narrow handle profile.

**Finiture standard / standard finishes**  
Anodizzato / anodized: Silver

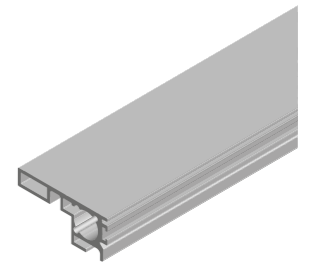
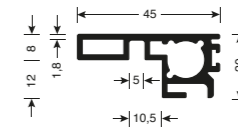

### PR19700023A

Profilo traverso superiore - inferiore.

Upper - lower horizontal profile.

**Finiture standard / standard finishes**  
Anodizzato / anodized: Silver

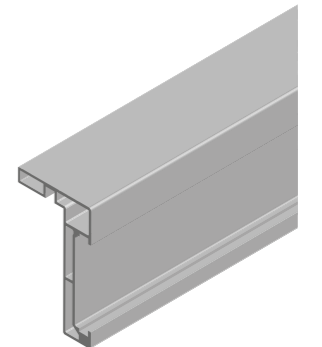
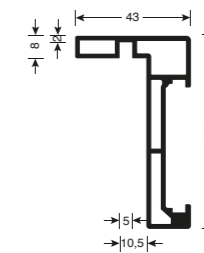

### PS19CS1001

Confezione per montaggio anta.

Finitura: Zincato

Kit for assembly door.  
Finish: Zinc plated

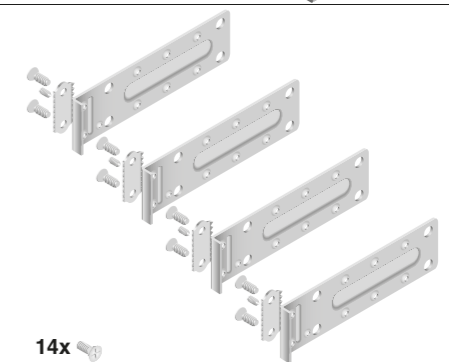

14x

Fianco laterale con recupero  
Long lateral side

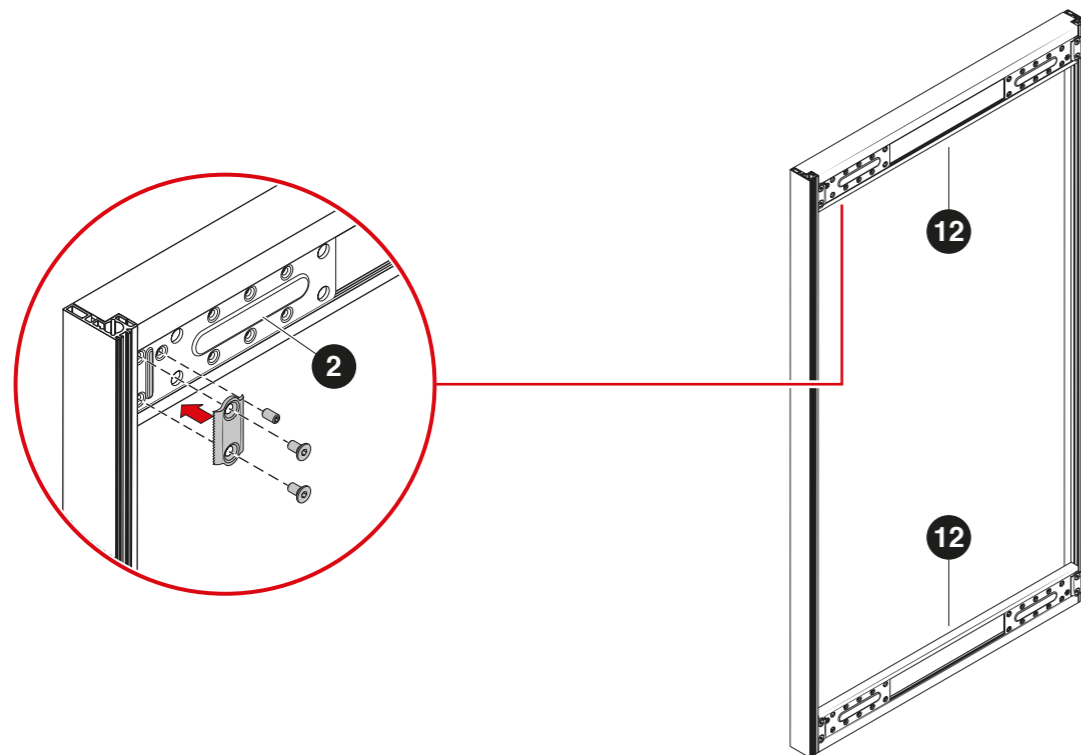
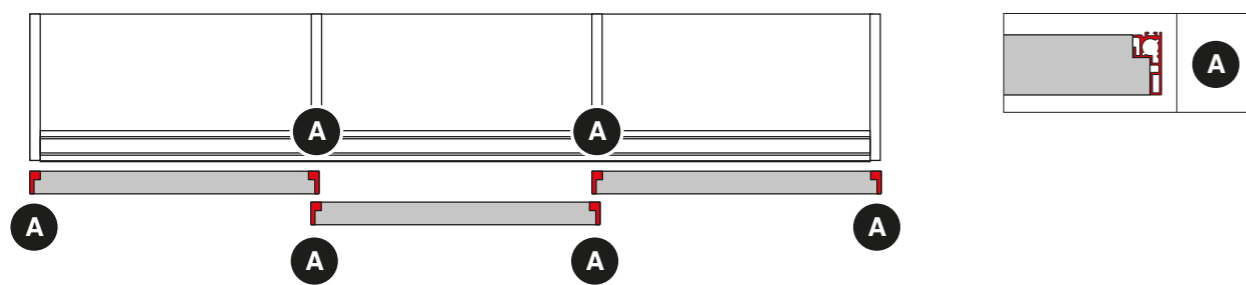
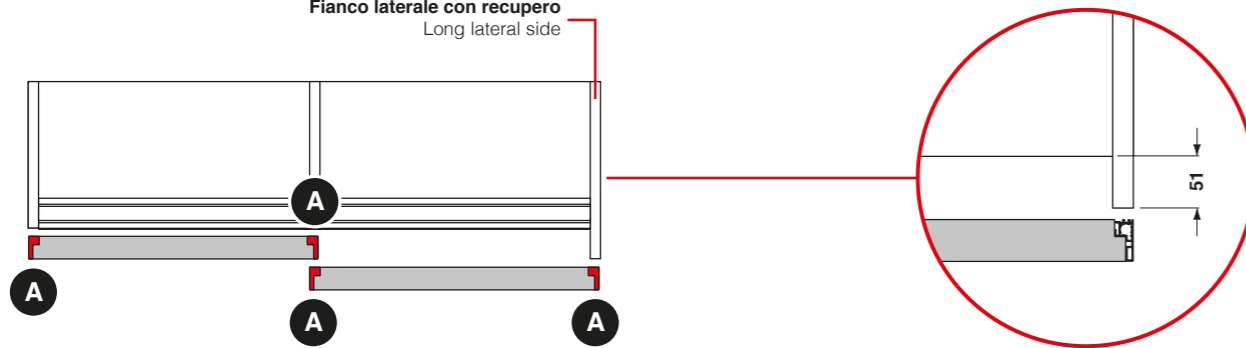

# PS19.3

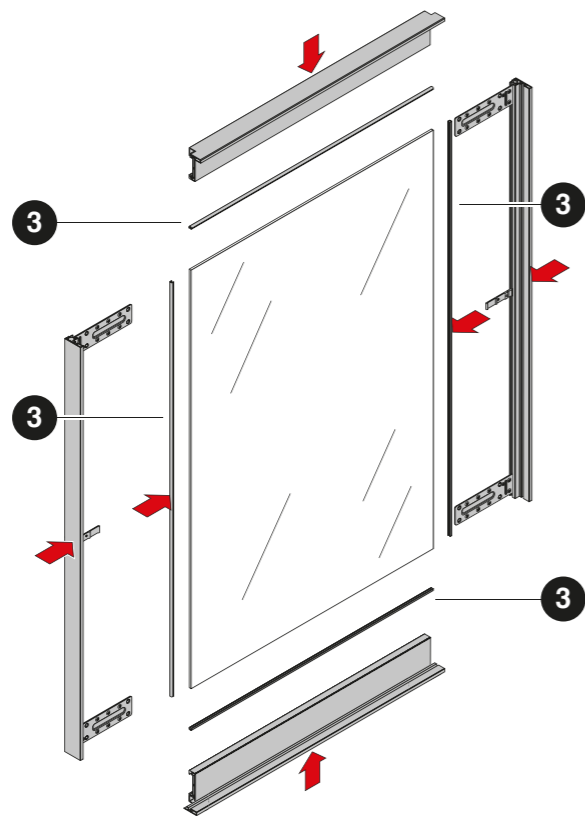
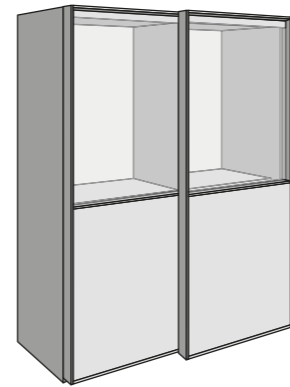

**ABBREVIAZIONI:**  
**WA** = larghezza anta  
**WP** = larghezza pannello  
**WG** = larghezza vetro  
**H1** = altezza anta  
**HP** = altezza pannello  
**HG** = altezza vetro

**ABBREVIATIONS:**  
**WA** = door width  
**WP** = panel width  
**WG** = glass width  
**H1** = door height  
**HP** = panel height  
**HG** = glass height

**PR20820002** Edge 0.8  
**PR20820004** Edge 0.6

Guarnizione per vetro.  
 Finitura: Neutro

Gasket for glass.  
 Finish: Neutral

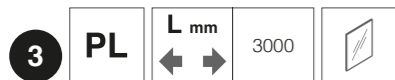
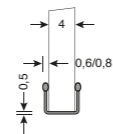

## PS19.3. Schede tecniche / Data sheets

### Calcolo dimensioni vetri e pannelli suddivisi in parti uguali.

Calculation of the dimensions of glasses and wooden panels divided in equal parts.

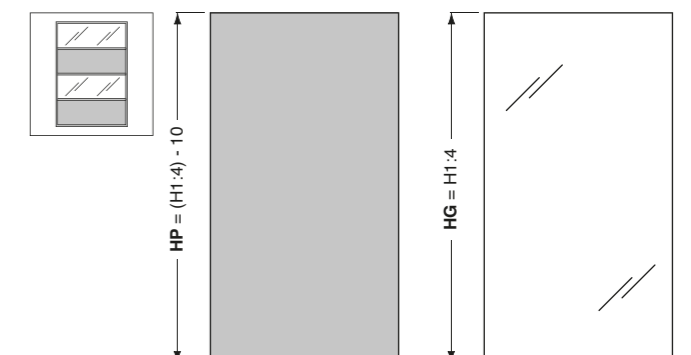
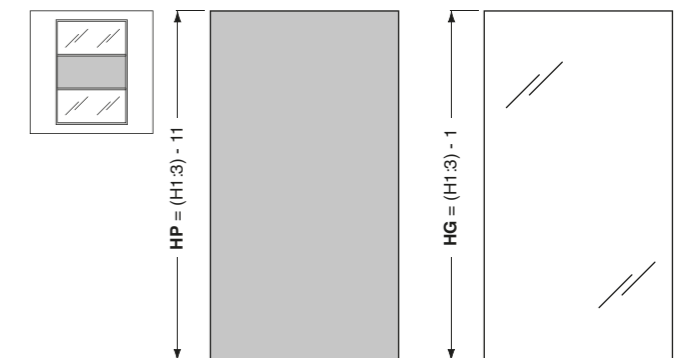
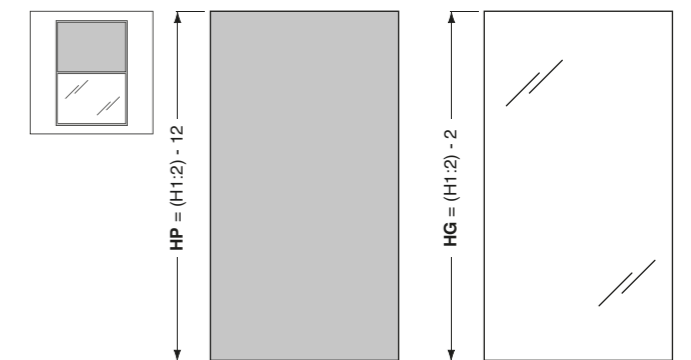
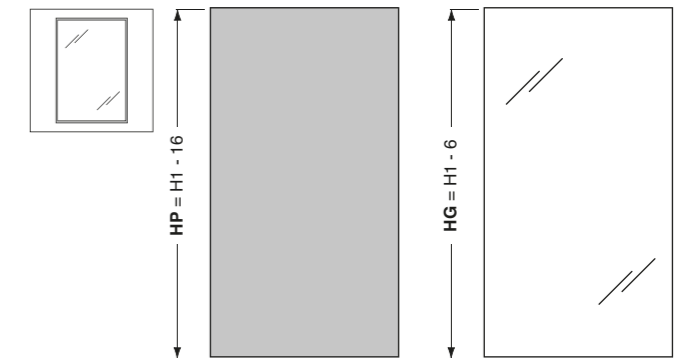
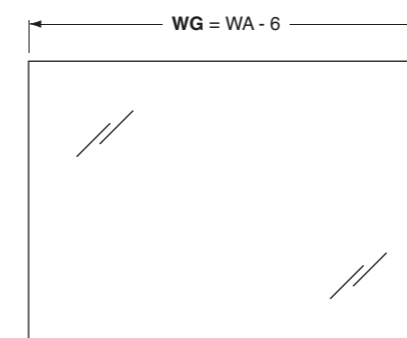
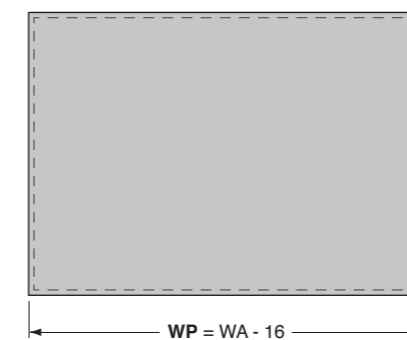
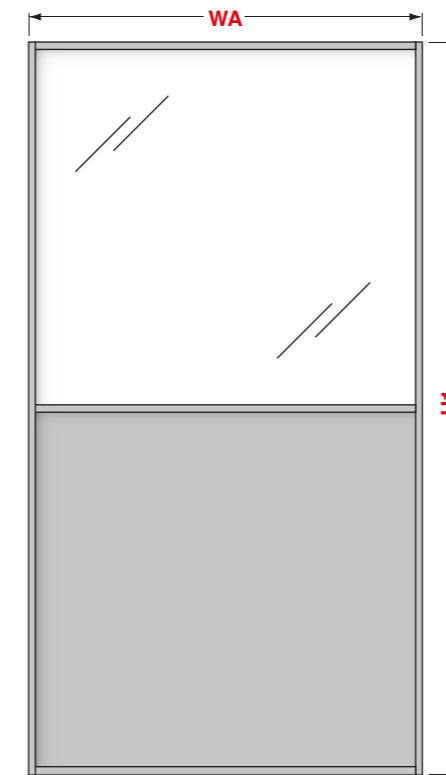

# PS19.3

option  
1

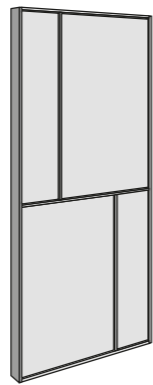

PS19.3. Schede tecniche / Data sheets

Montaggio del pannello in legno.  
Assembly of the wooden panel.

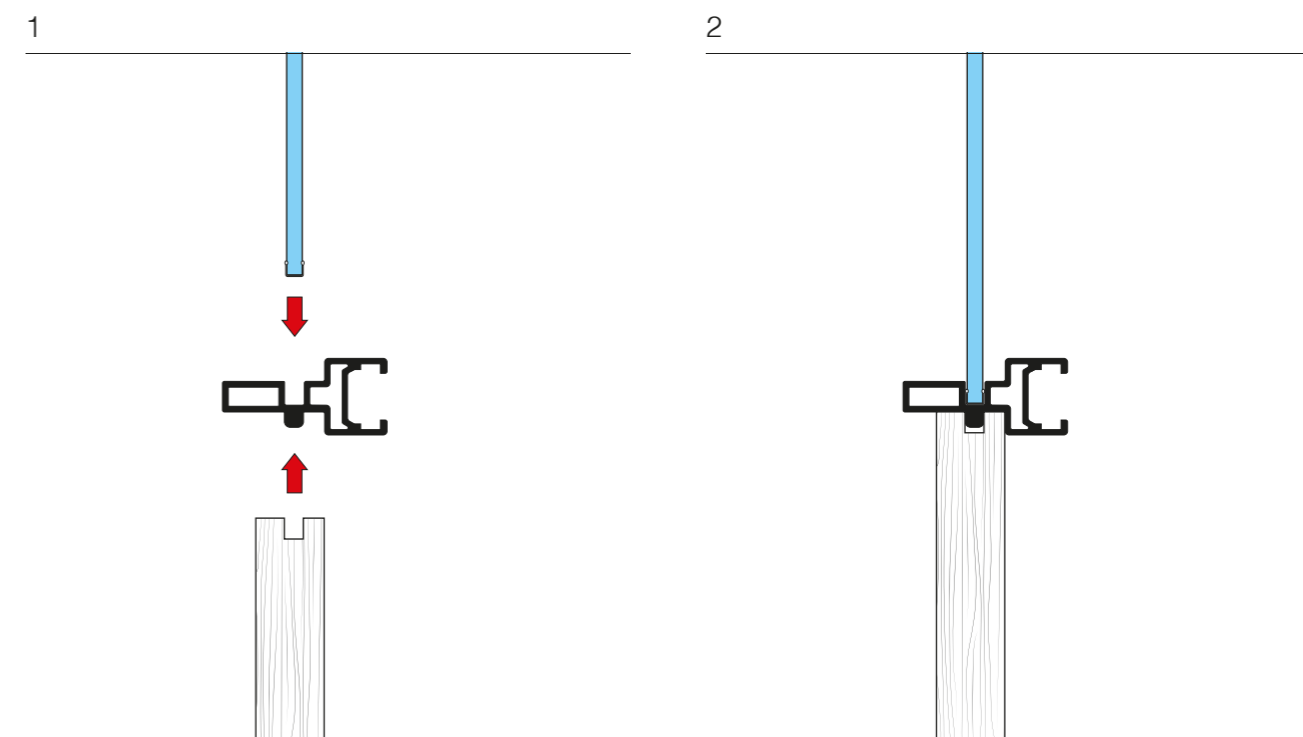
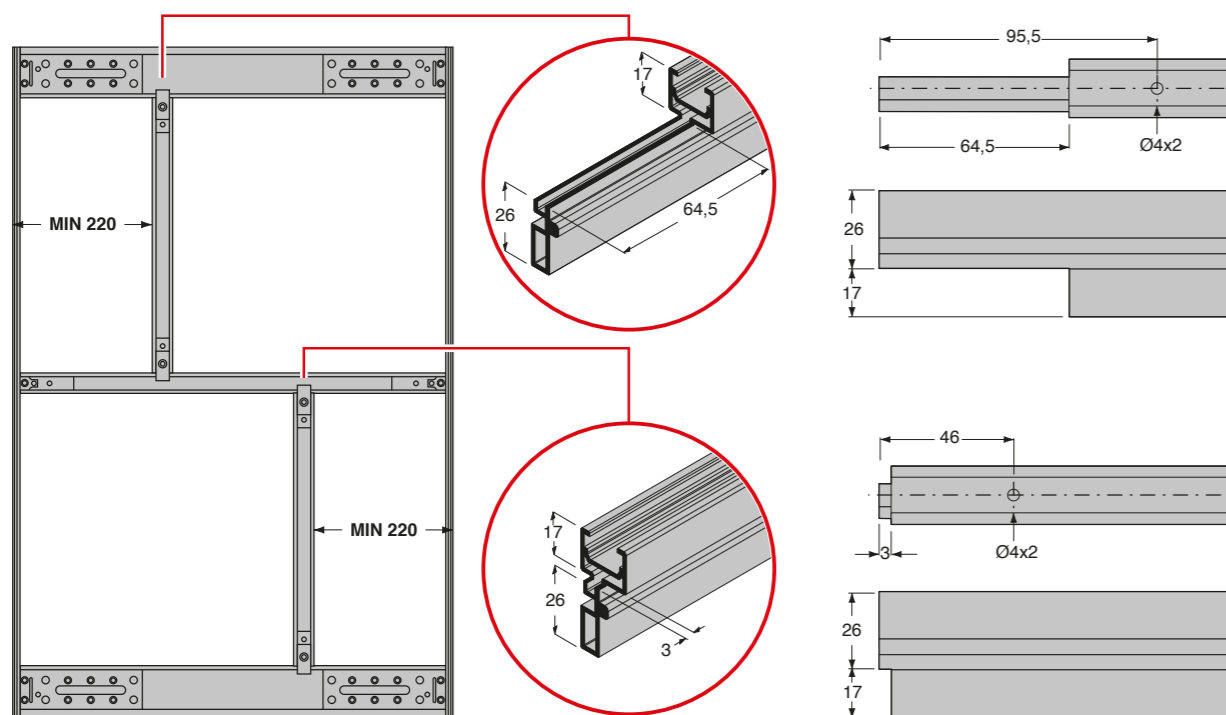
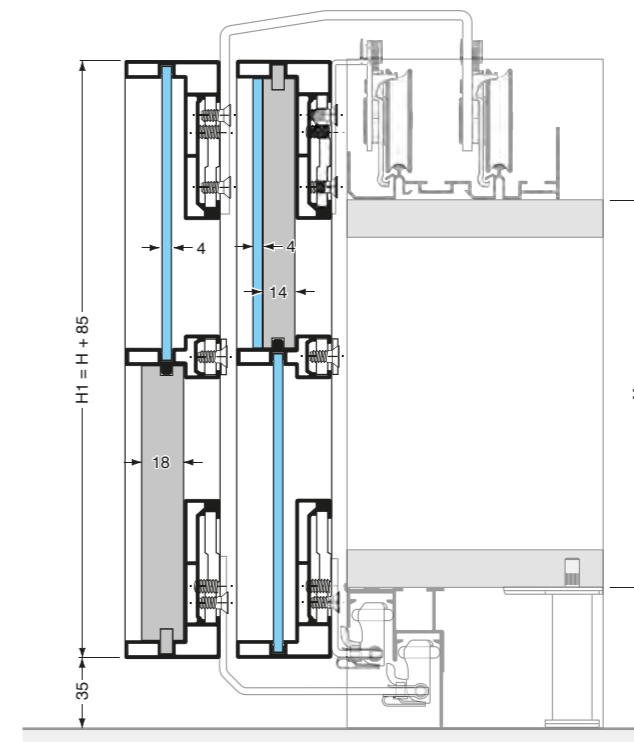
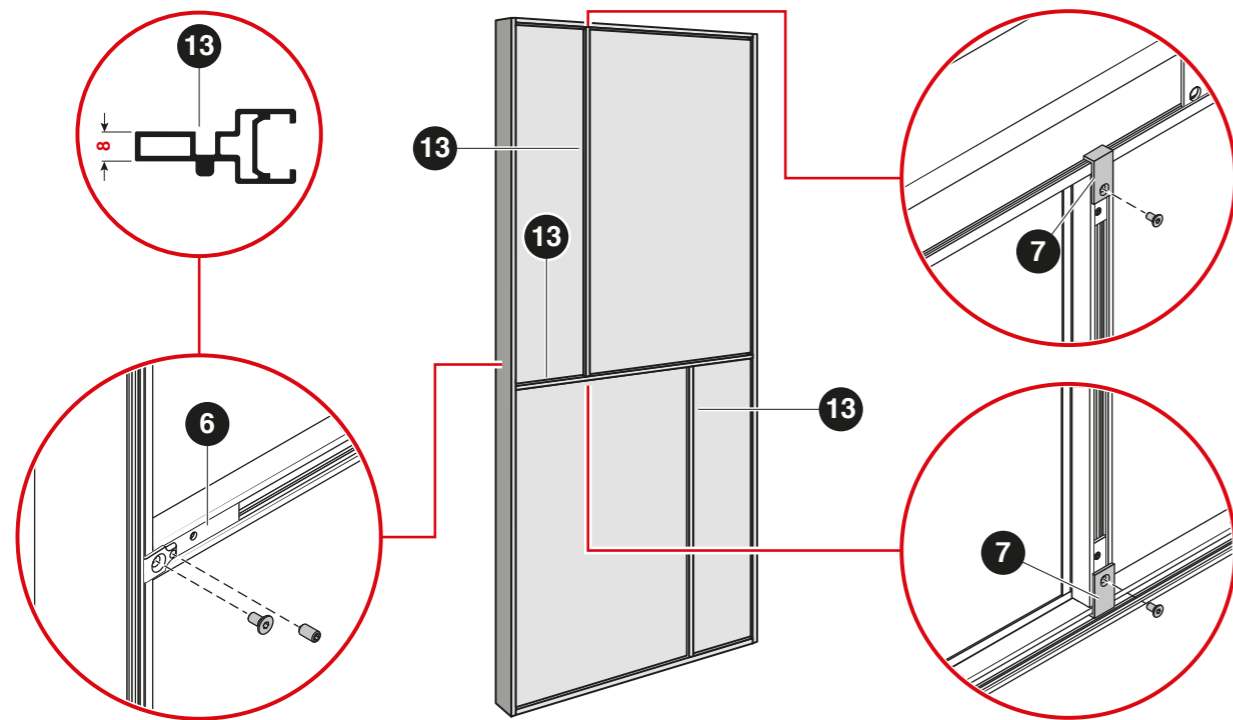

**Montaggio del pannello in legno.**  
Assembly of the wooden panel.

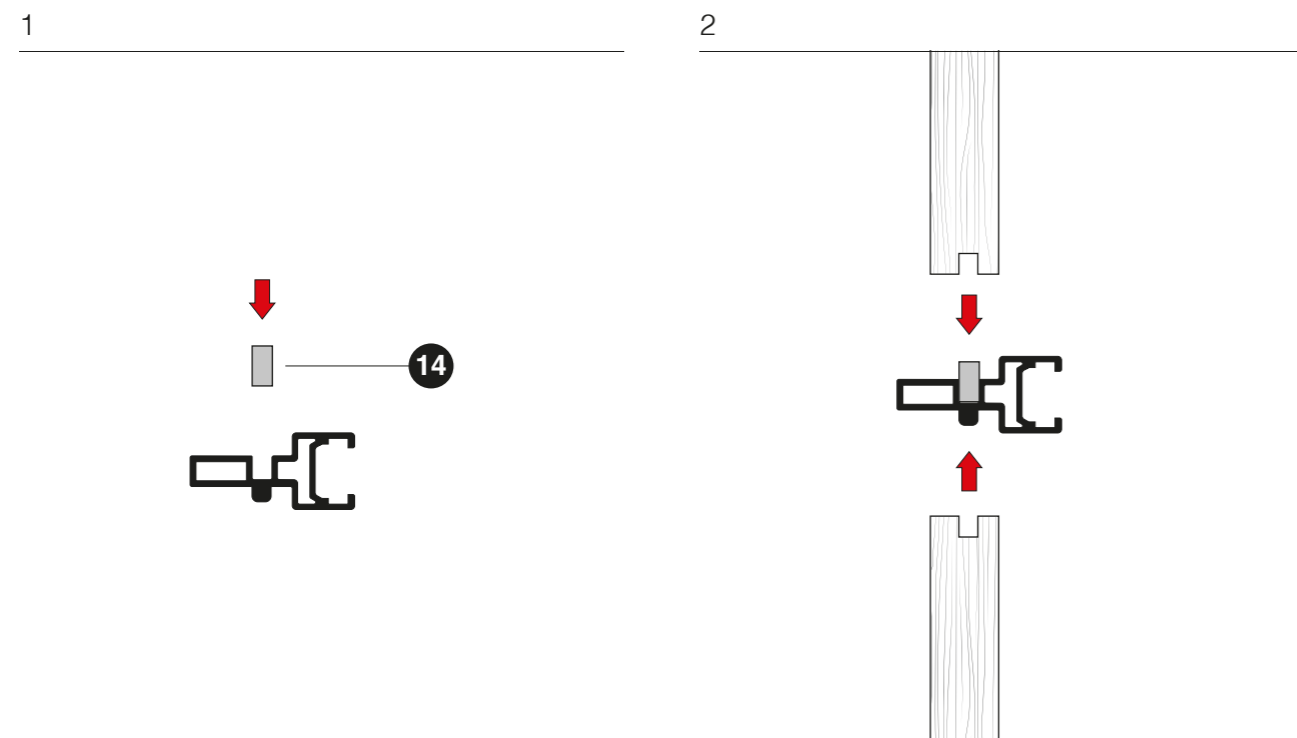
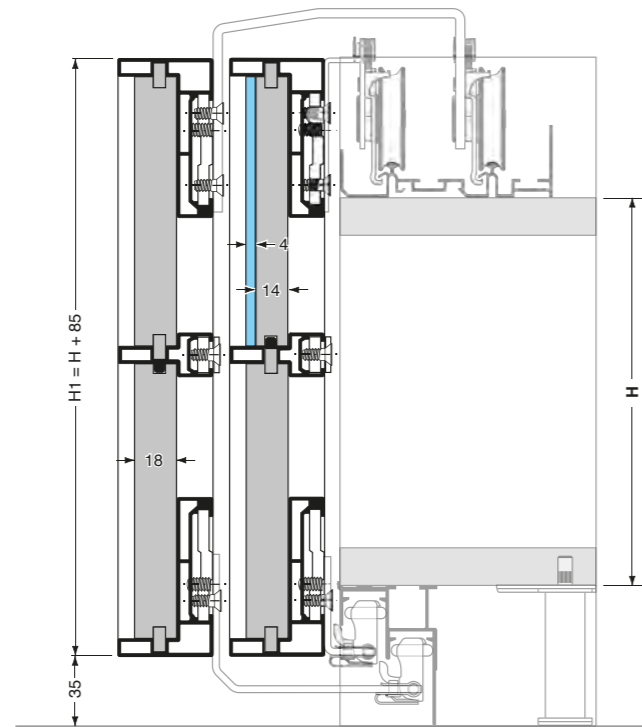

**PR19700033A**

Profilo traversino.

Cross profile.

**Finiture standard / standard finishes**  
Anodizzato / anodized: Silver

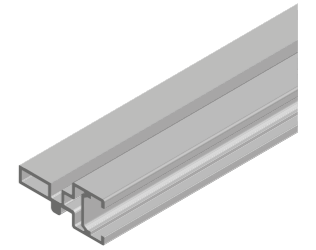
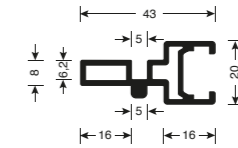

**13** AL L mm 5300

**PS19CS7212**

Confezione per montaggio traversino orizzontale.  
Finitura: Silver

Kit for assembly horizontal cross profile.  
Finish: Silver

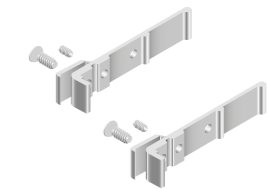

**6** AL

**PS19CS70020016**

Confezione per montaggio traversino verticale.  
Finitura: Silver

Kit for assembly vertical cross profile.  
Finish: Silver

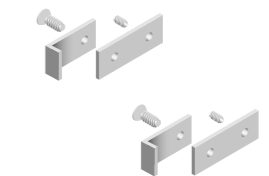

**7** AL

**PR20820002** Edge 0.8

**PR20820004** Edge 0.6

Guarnizione per vetro.  
Finitura: Neutro

Gasket for glass.  
Finish: Neutral

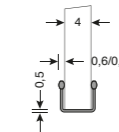

**3** PL L mm 3000

**PR517000100050**

Profilo ad innesto per montaggio pannello.  
Finitura: Grezzo

Interlocking profile for panel assembly.  
Finish: Raw

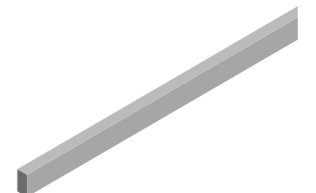

**14** AL L mm 6000



# PS19.3

option  
2

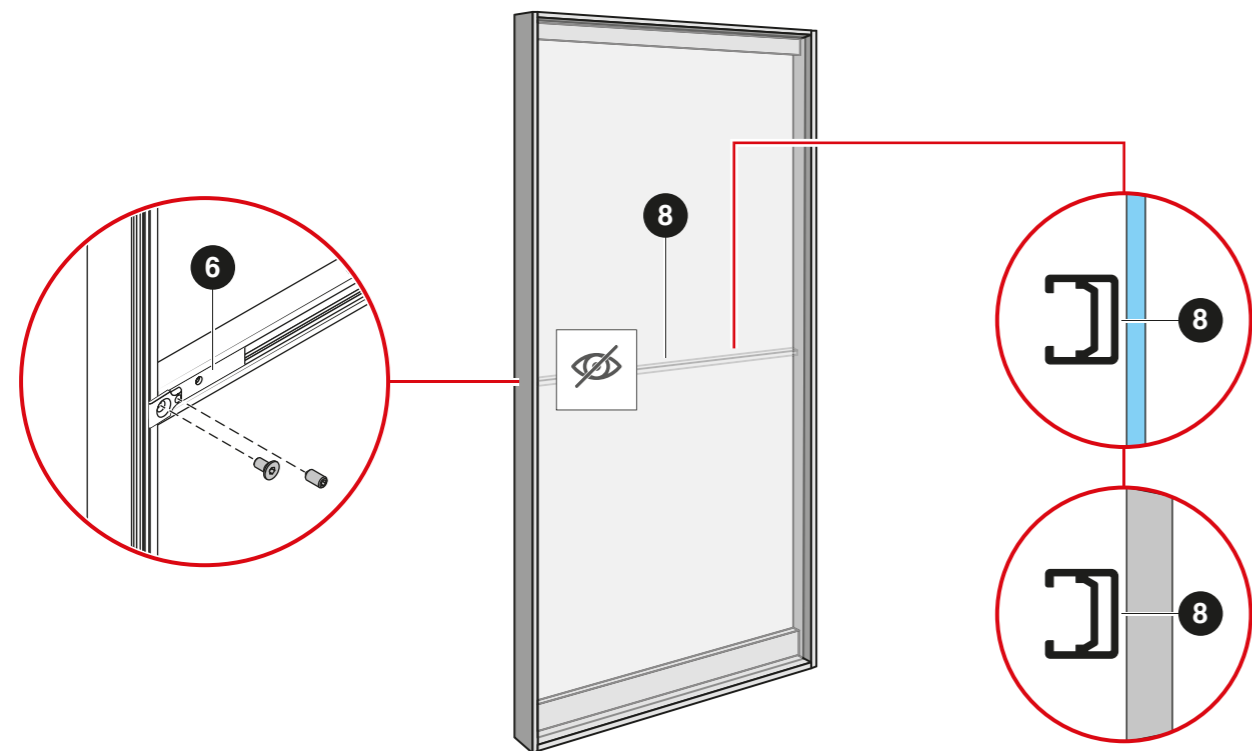

## PR1970021A

Profilo traversino senza sede vetro.

Cross profile without glass gasket seat.

### Finiture standard / standard finishes

Anodizzato / anodized: Silver  
Verniciato / painted: Deep black, Metal grey, Moonlight

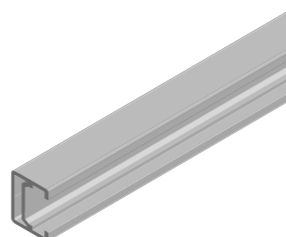
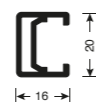

## PS19CS7212

Confezione per montaggio traversino orizzontale.

Finitura: Silver

Kit for assembly horizontal cross profile.

Finish: Silver

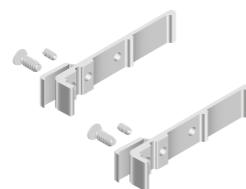

## PS19.3. Lista componenti / Parts list

### Accessori complementari

Additional accessories

#### PZ03480590A

Spazzolino parapolvere.

Finitura: Nero

Save-dust brush.

Finish: Black

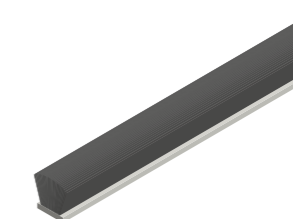
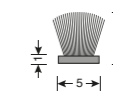

#### BR

Raddrizza ante.

Doors straightener.

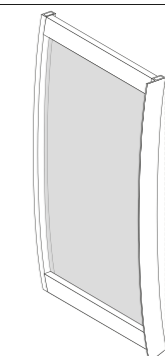

# PS19.4

**PS48**  
compatible

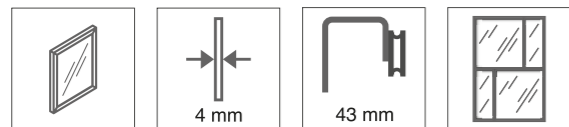
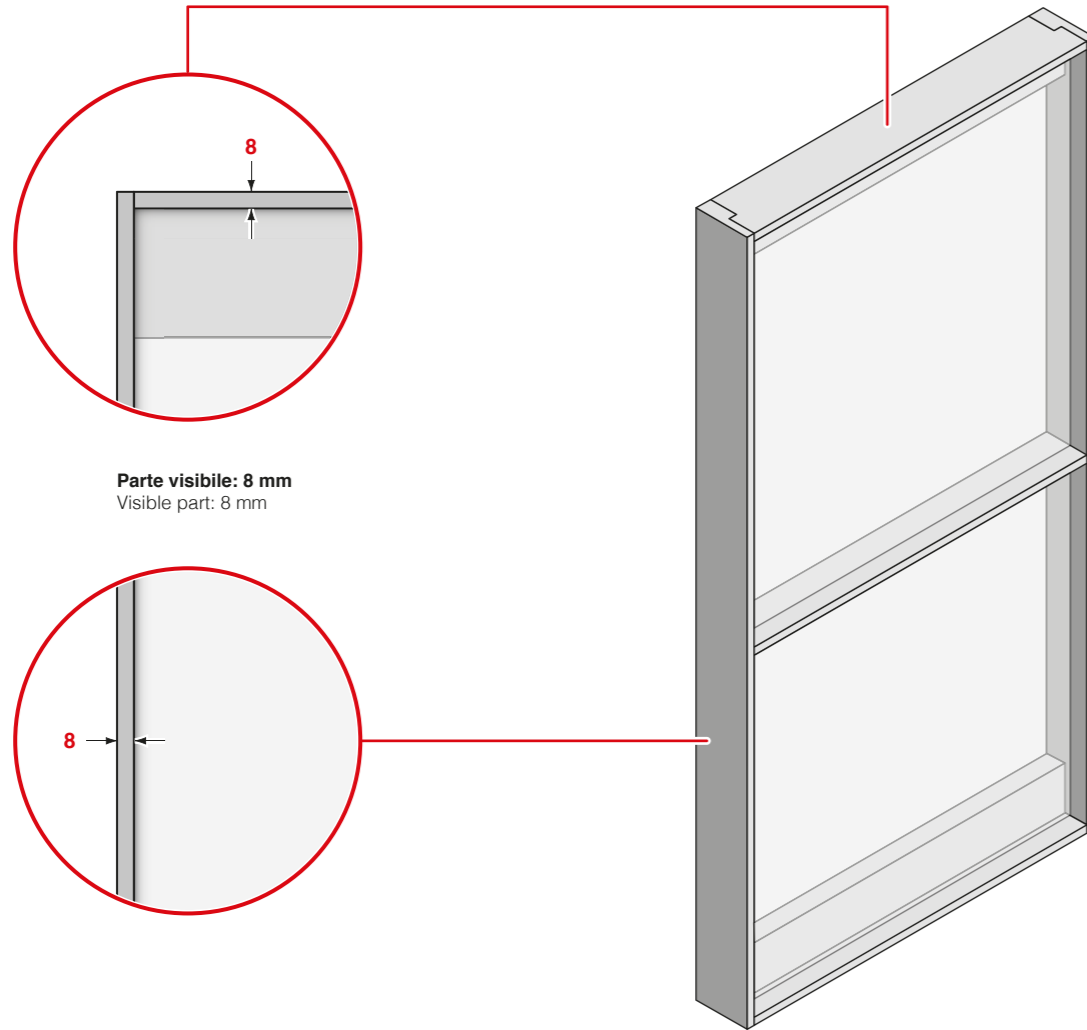
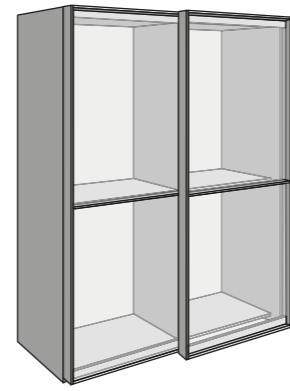

## PS19.4. Schede tecniche / Data sheets

1

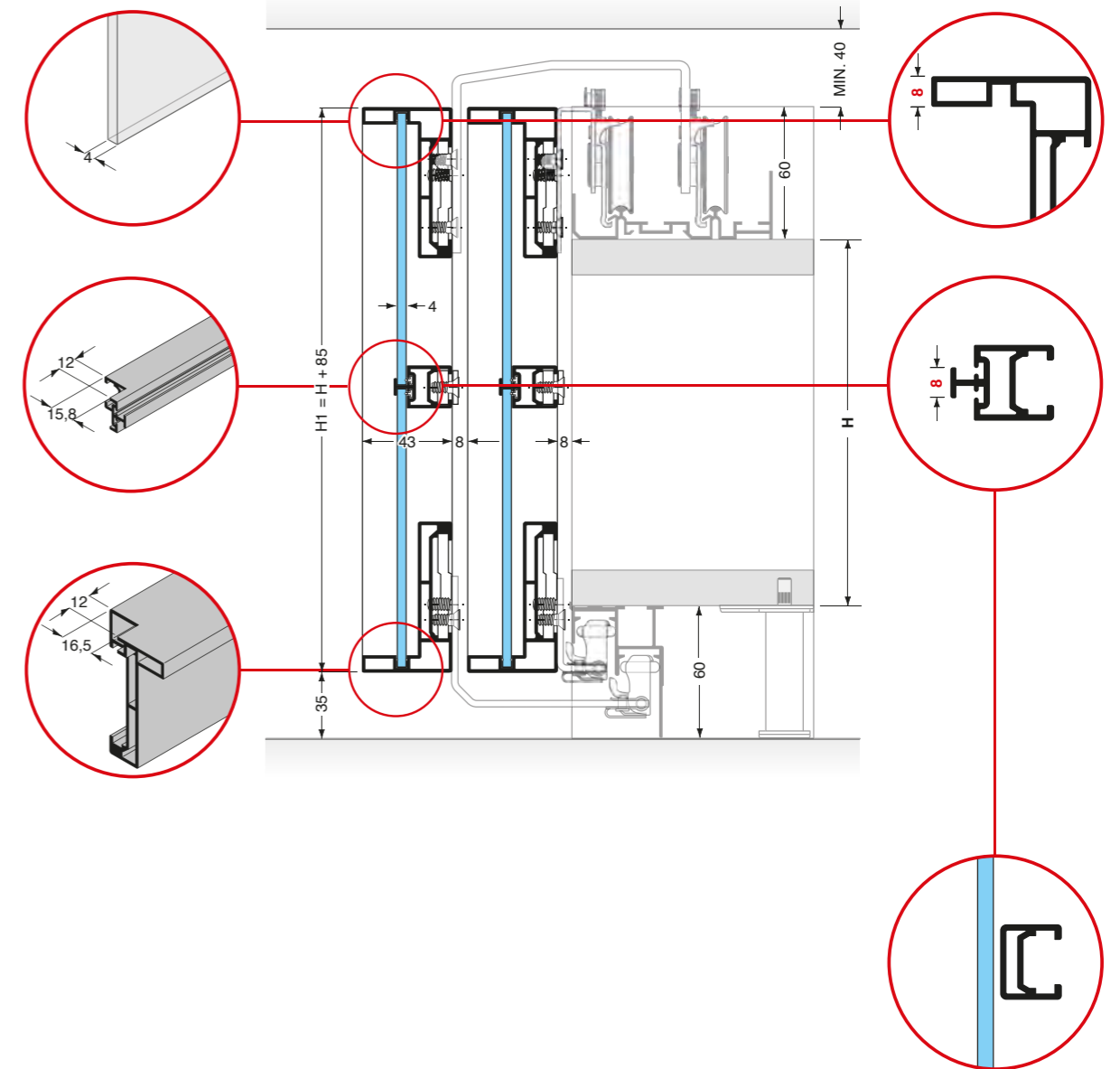

**Pattini compatibili / Compatible slides.**

**PS48AP2E4301**

**PS48AP2E01**

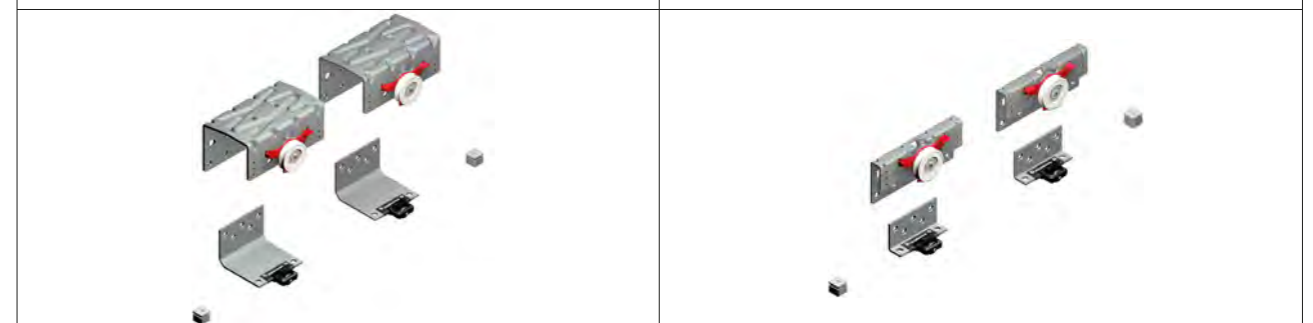

2

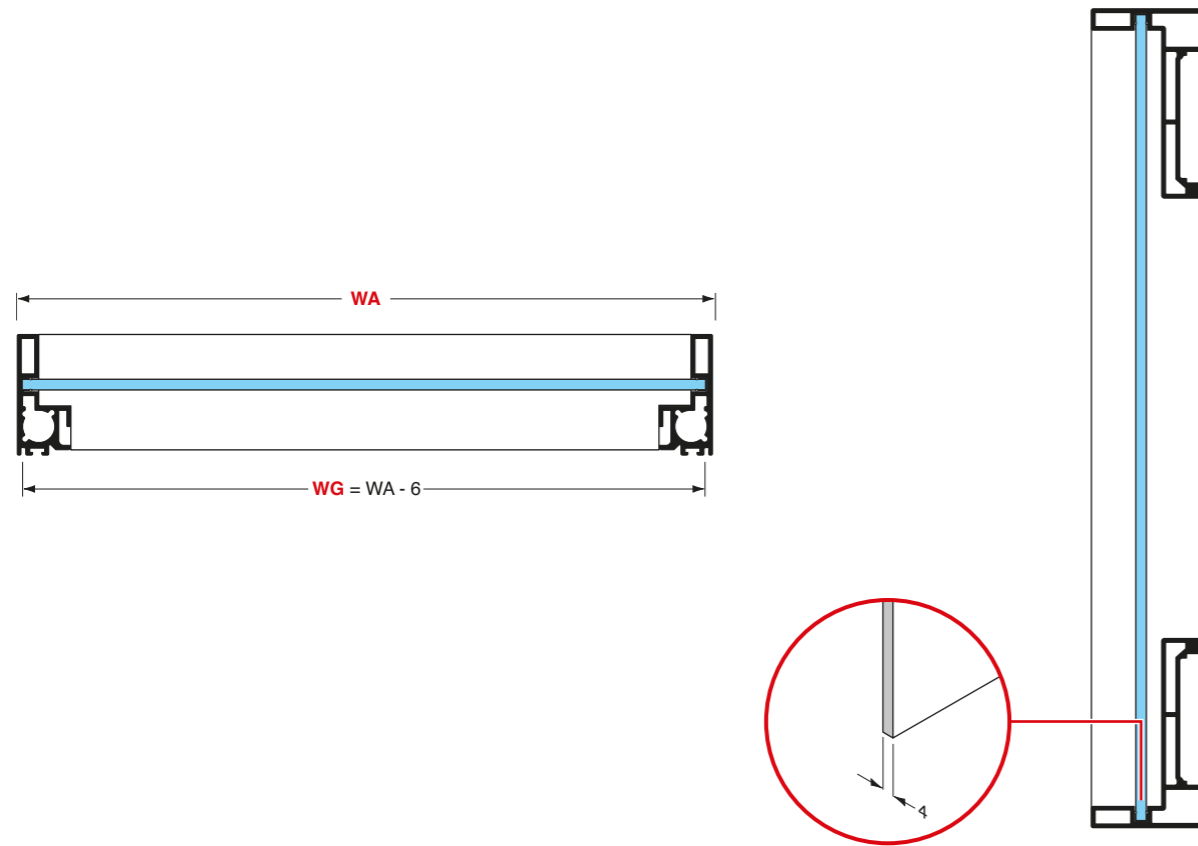

3

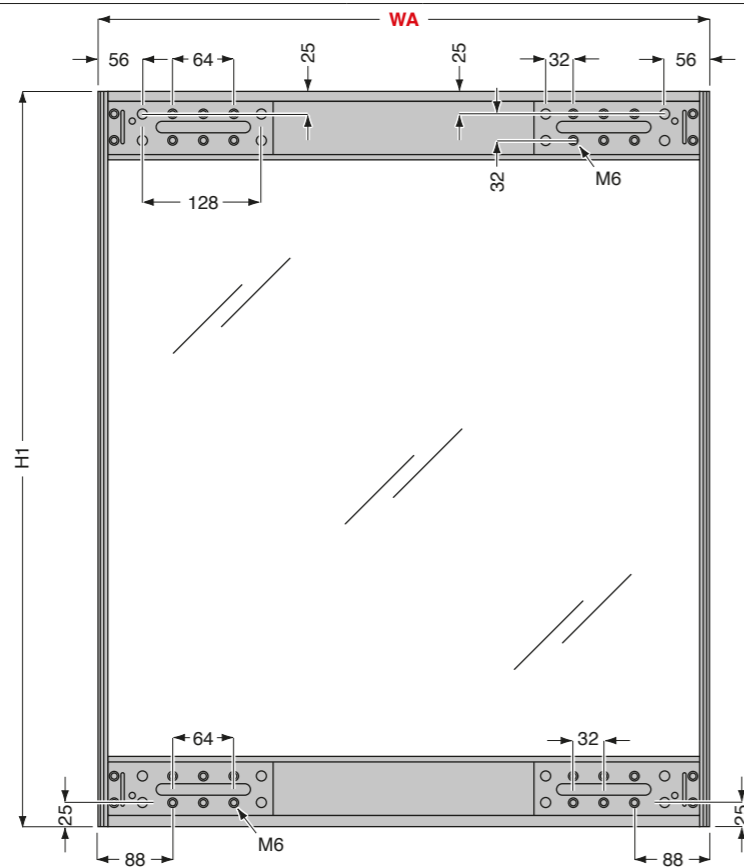

3

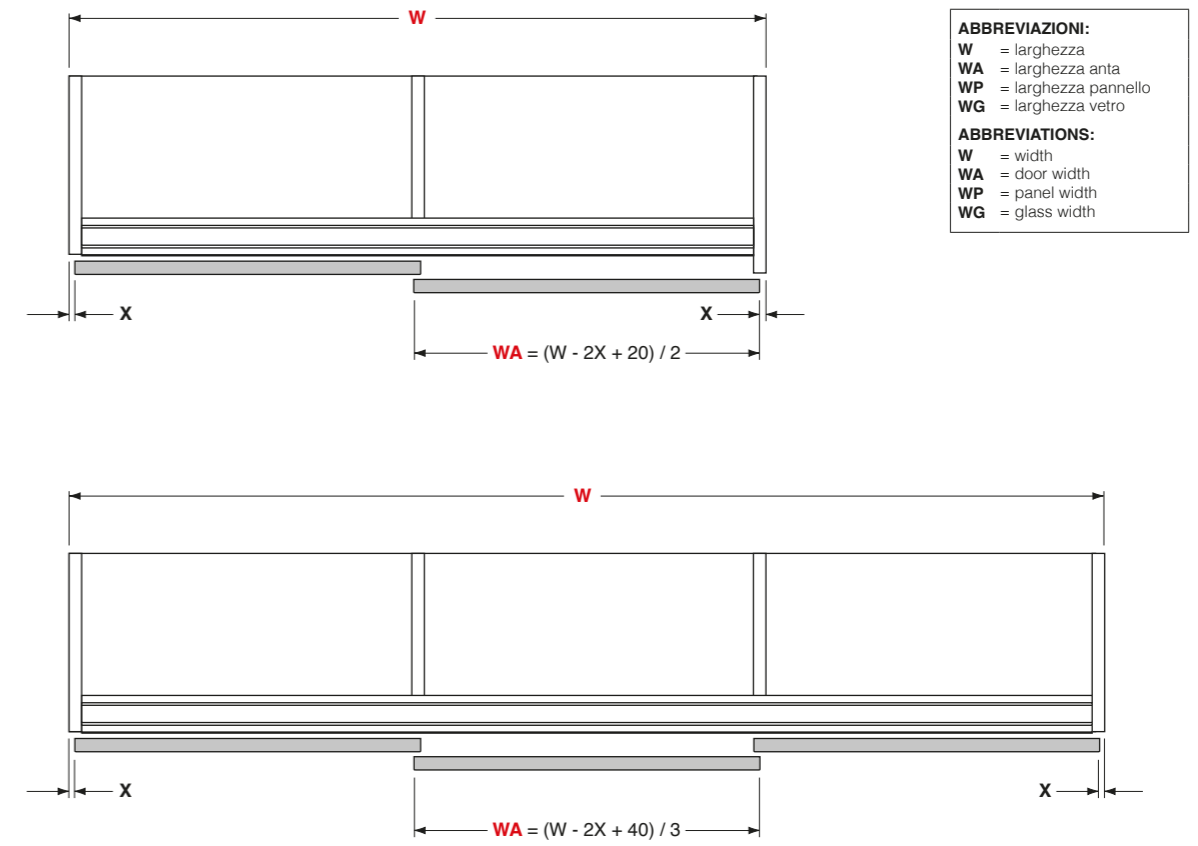

# PS19.4

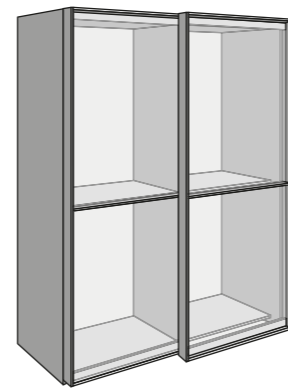

## PS19.4. Lista componenti / Parts list

### PR19700022A

Profilo maniglia bassa.

Narrow handle profile.

**Finiture standard / standard finishes**  
Anodizzato / anodized: Silver

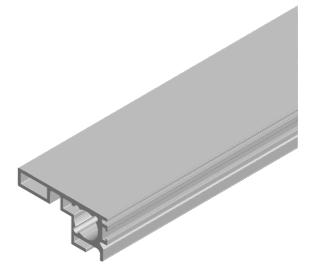
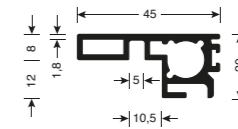

### PR19700023A

Profilo traverso superiore - inferiore.

Upper - lower horizontal profile.

**Finiture standard / standard finishes**  
Anodizzato / anodized: Silver

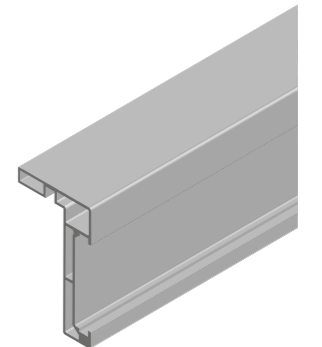
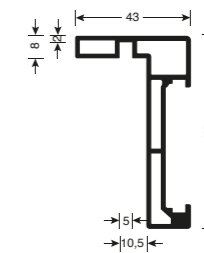

### PS19CS1001

Confezione per montaggio anta.

Finitura: Zincato

Kit for assembly door.  
Finish: Zinc plated

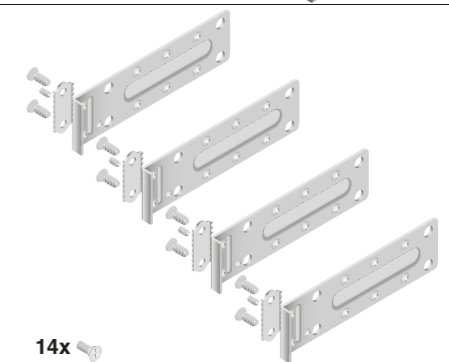

14x

Fianco laterale con recupero  
Long lateral side

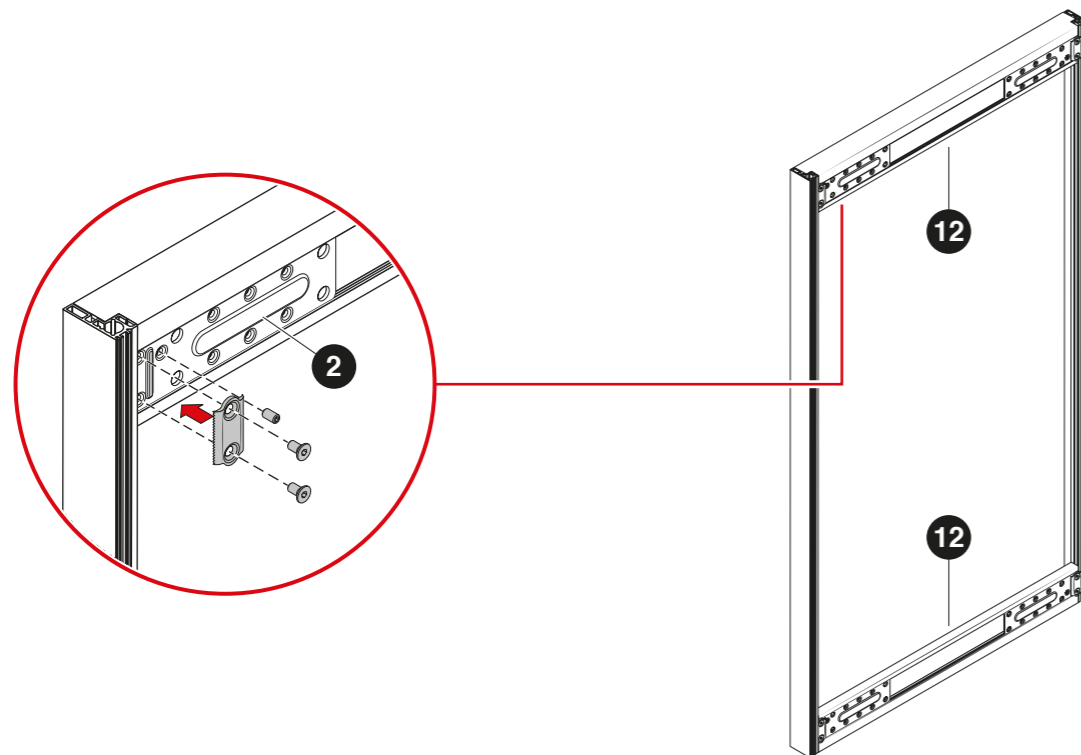
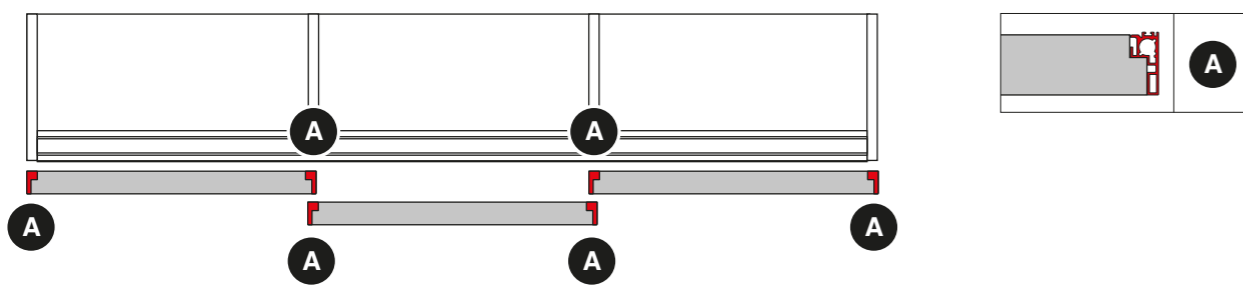
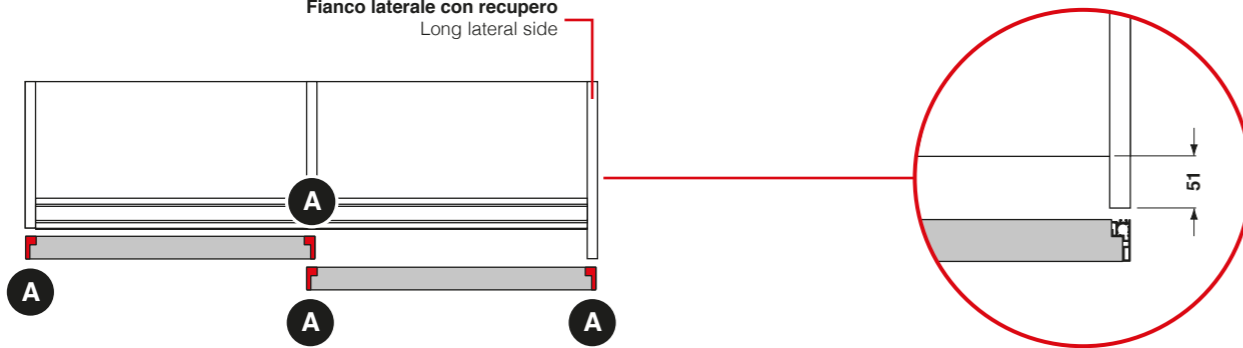

# PS19.4

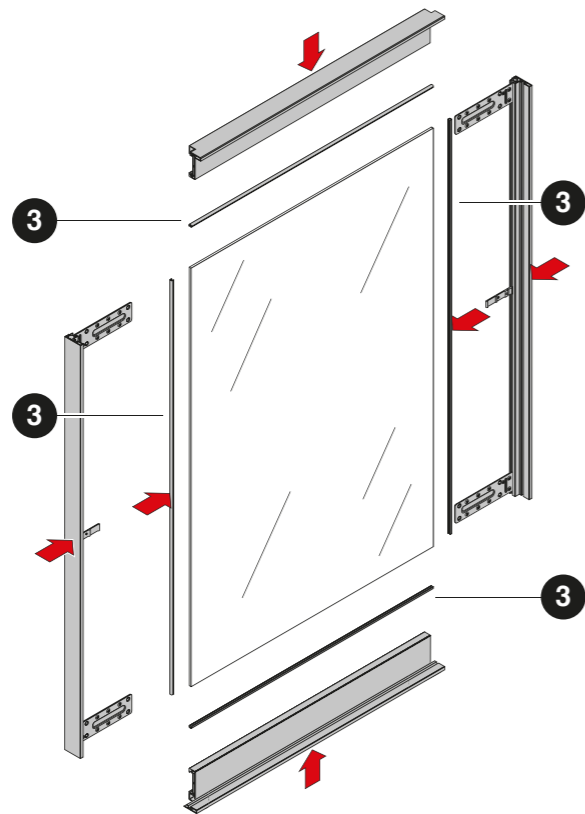
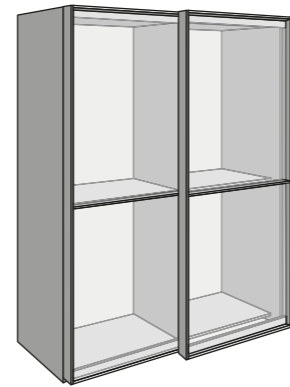

**ABBREVIAZIONI:**  
**WA** = larghezza anta  
**WG** = larghezza vetro  
**H1** = altezza anta  
**HG** = altezza vetro

**ABBREVIATIONS:**  
**WA** = door width  
**WG** = glass width  
**H1** = door height  
**HG** = glass height

**PR20820002** Edge 0.8  
**PR20820004** Edge 0.6

Guarnizione per vetro.  
 Finitura: Neutro

Gasket for glass.  
 Finish: Neutral

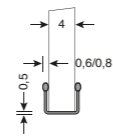

## PS19.4. Schede tecniche / Data sheets

### Calcolo dimensioni vetri e pannelli suddivisi in parti uguali.

Calculation of the dimensions of glasses and wooden panels divided in equal parts.

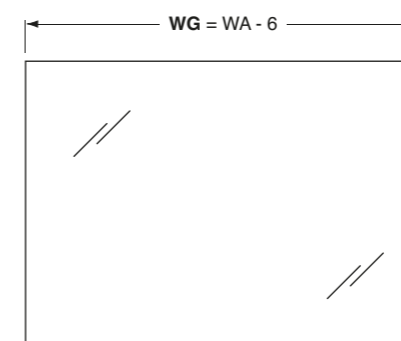
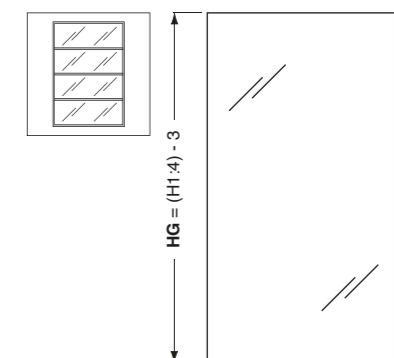
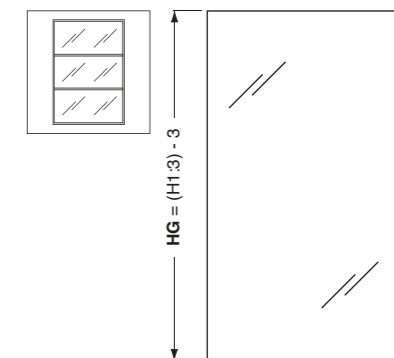
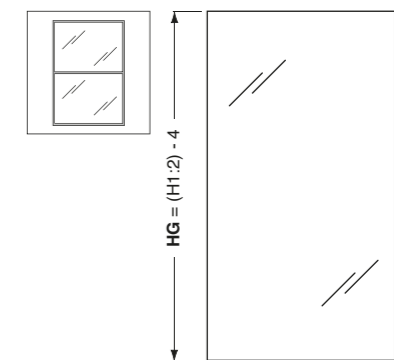
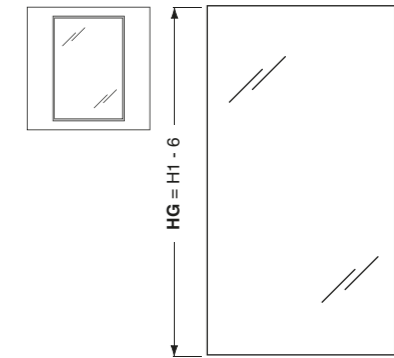
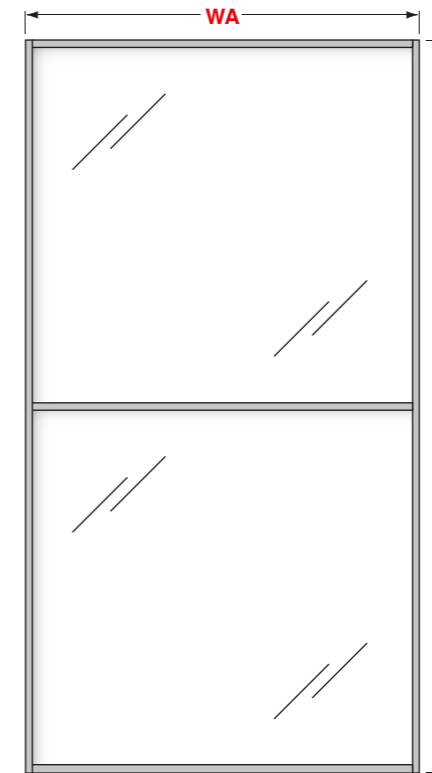

# PS19.4

option  
1

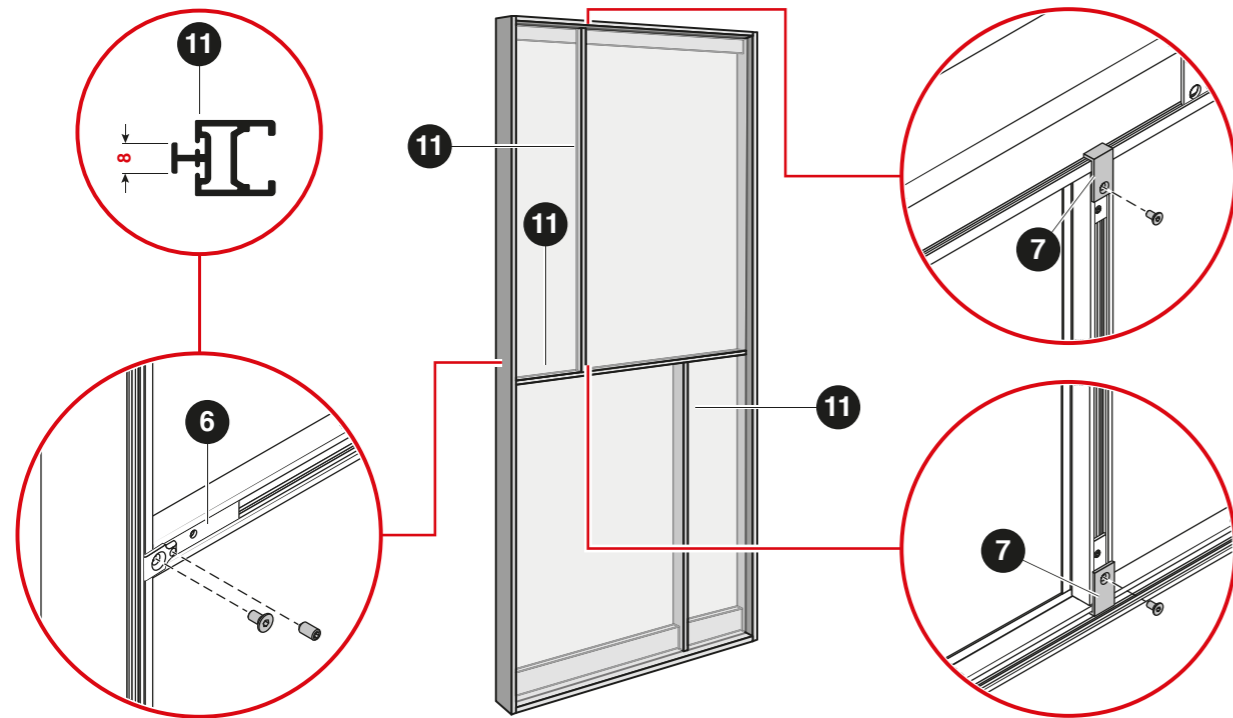
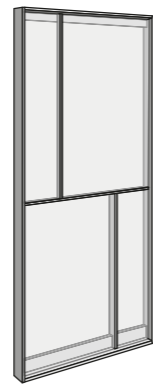

## PS19.4. Lista componenti / Parts list

### PR19700024A

Profilo traversino.

Cross profile.

Finiture standard / standard finishes  
Anodizzato / anodized: Silver

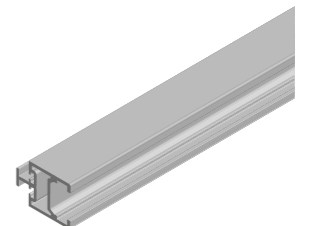
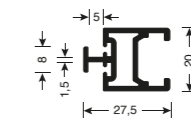

11	AL	L mm	5300
			6300

### PR20810001

Guarnizione per vetro.  
Finitura: Trasparente

Gasket for glass.  
Finish: Transparent

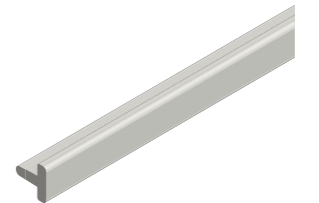
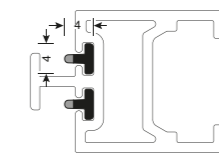

PL		L mm	3000

### PS19CS7212

Confezione per montaggio traversino orizzontale.  
Finitura: Silver

Kit for assembly horizontal cross profile.  
Finish: Silver

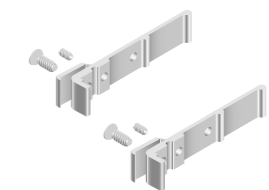

6	AL
---	----

### PS19CS70020016

Confezione per montaggio traversino verticale.  
Finitura: Silver

Kit for assembly vertical cross profile.  
Finish: Silver

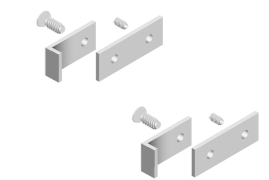

7	AL
---	----

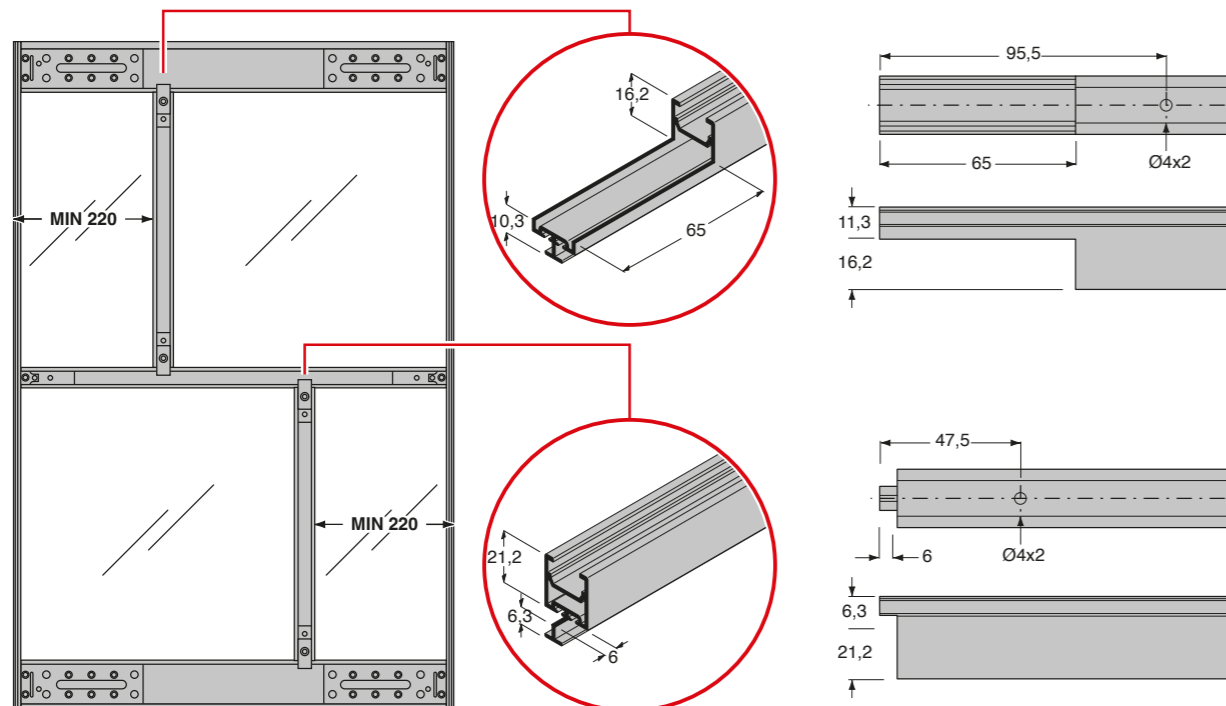

# PS19.4

option  
2

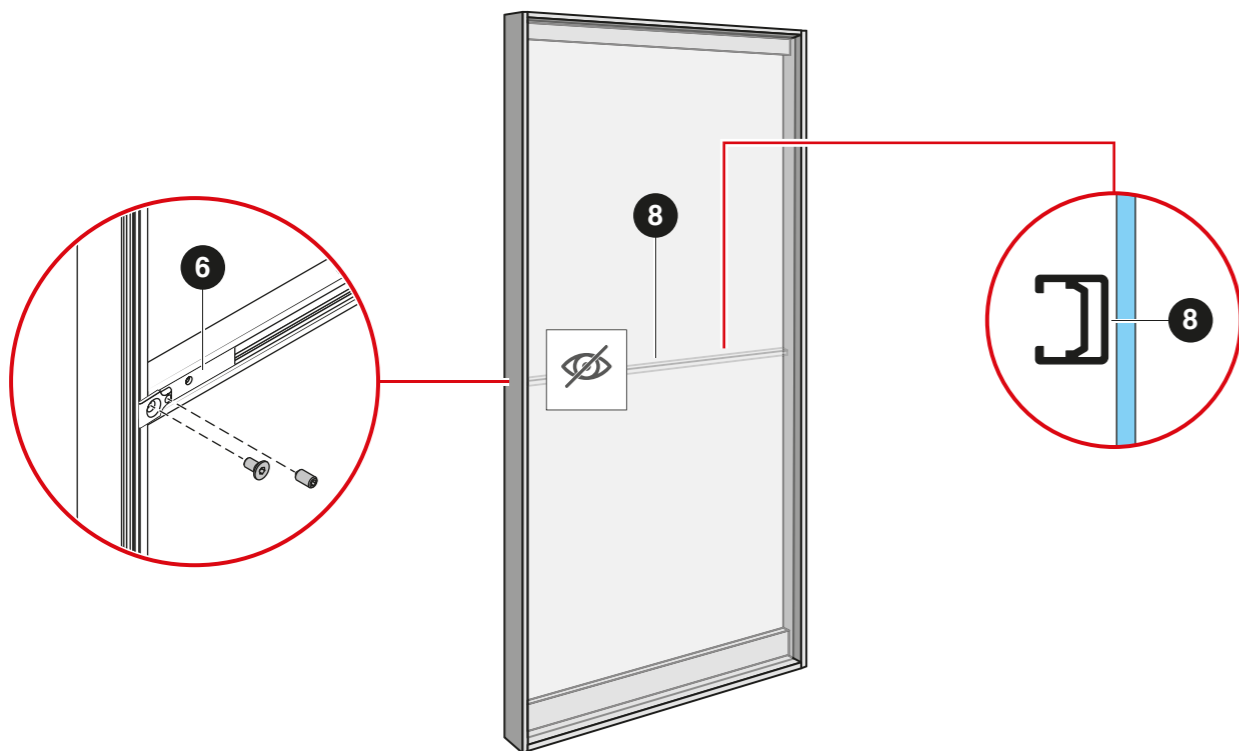

## PR1970021A

Profilo traversino senza sede vetro.

Cross profile without glass gasket seat.

### Finiture standard / standard finishes

Anodizzato / anodized: Silver  
Verniciato / painted: Deep black, Metal grey, Moonlight

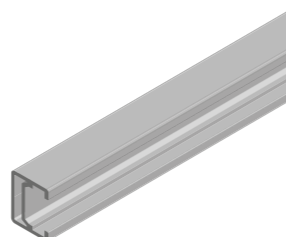
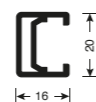
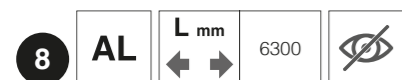

## PS19CS7212

Confezione per montaggio traversino orizzontale.  
Finitura: Silver

Kit for assembly horizontal cross profile.  
Finish: Silver

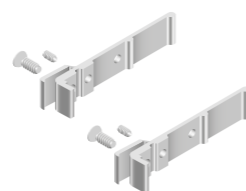

## PS19.4. Lista componenti / Parts list

### Accessori complementari

### Additional accessories

#### PZ03480590A

Spazzolino parapolvere.  
Finitura: Nero

Save-dust brush.  
Finish: Black

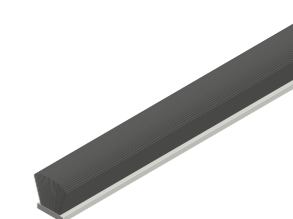
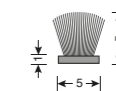

#### BR

Raddrizza ante.

Doors straightener.

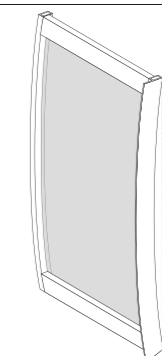

# PS19.5

**PS40**  
compatible

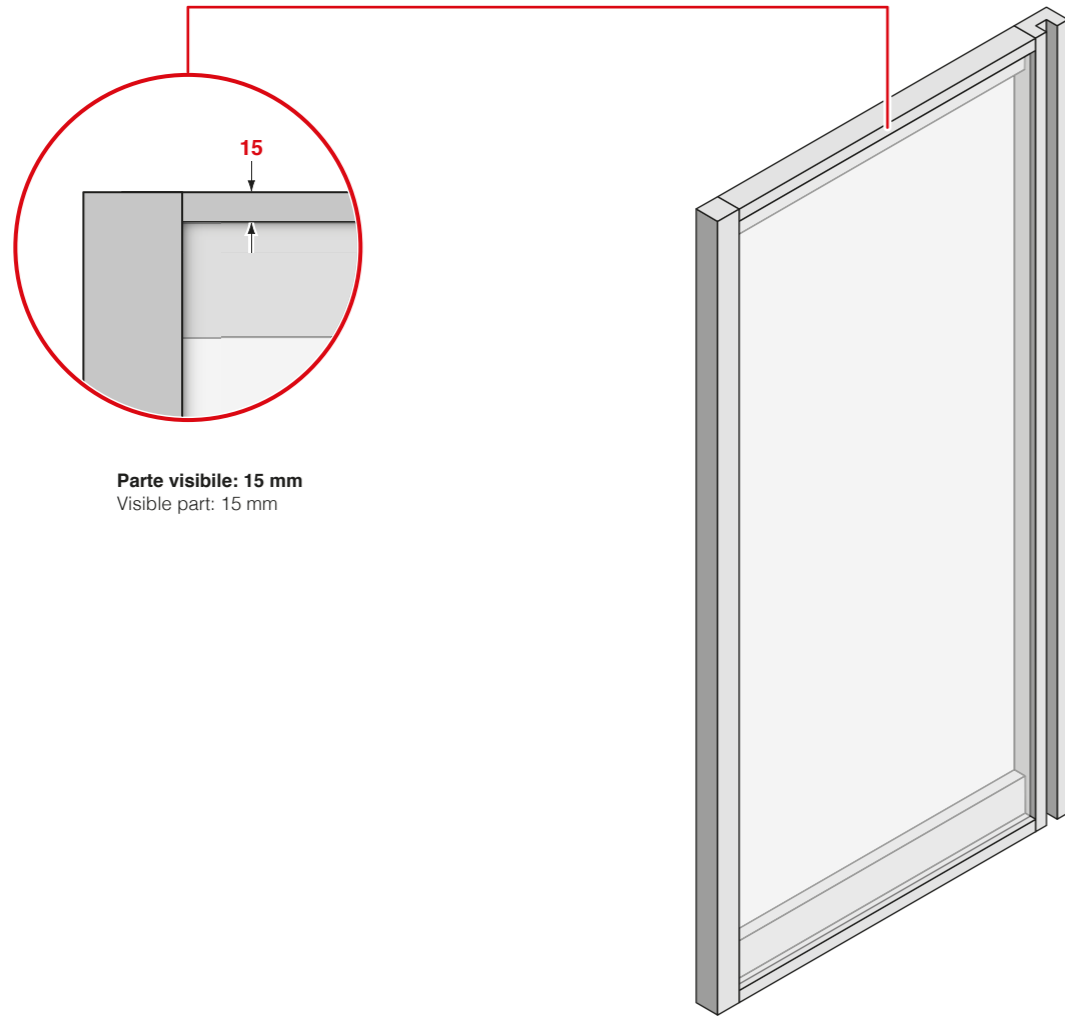
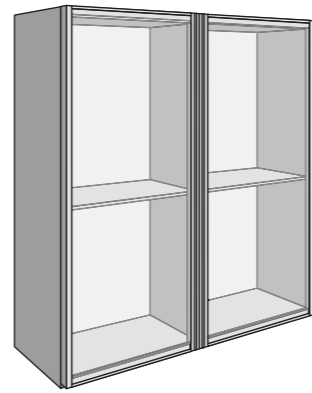

## PS19.5. Schede tecniche / Data sheets

1

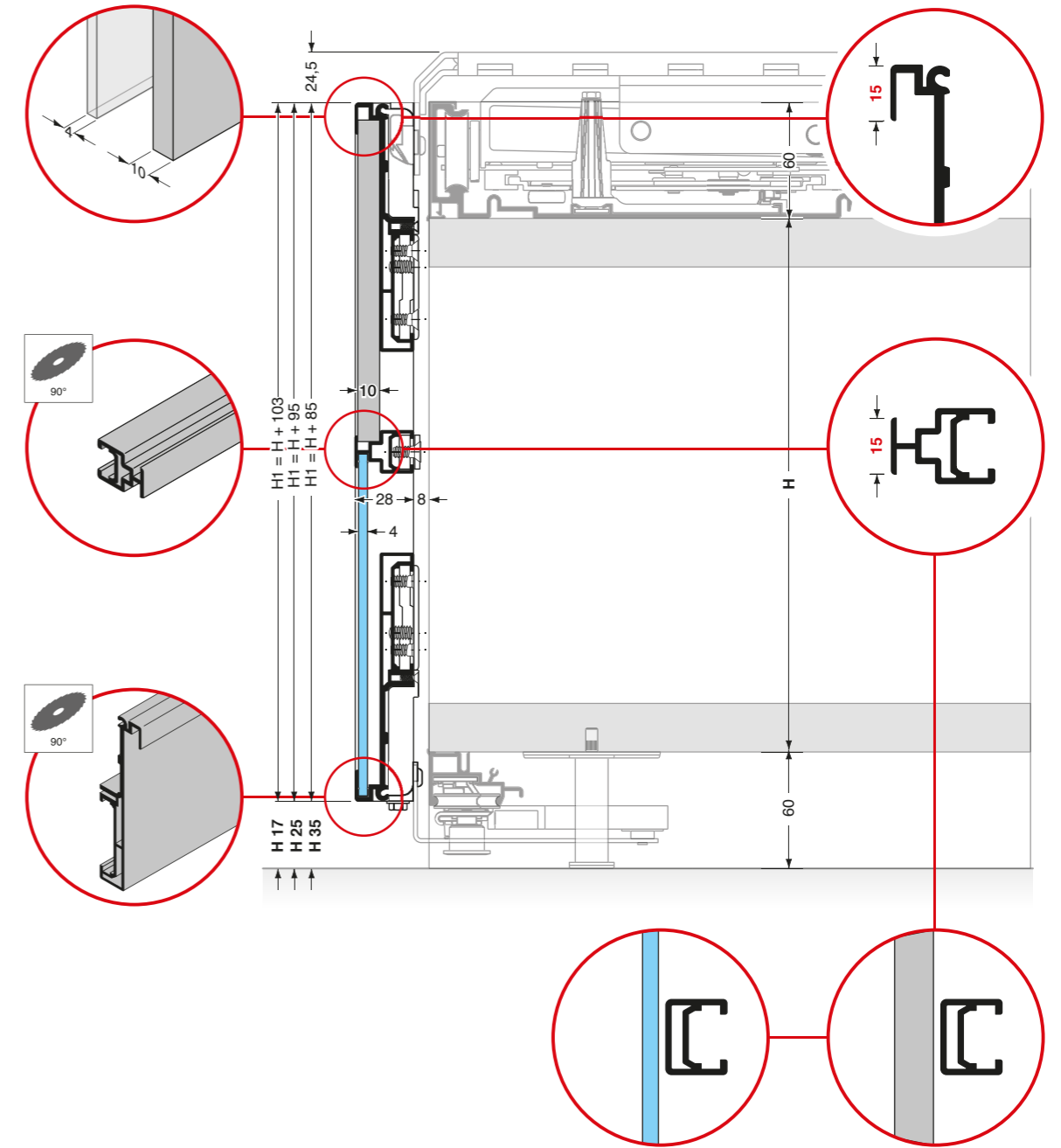

**Pattini compatibili / Compatible slides.**

PS40AP2F05D	PS40AP2F08D	PS40AP2F05S	PS40AP2F08S



# PS19.5

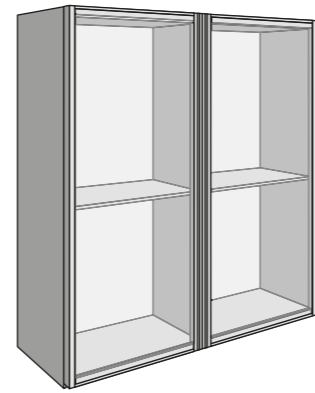
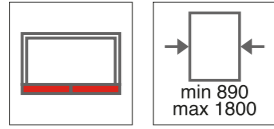

## PS19.5. Schede tecniche / Data sheets

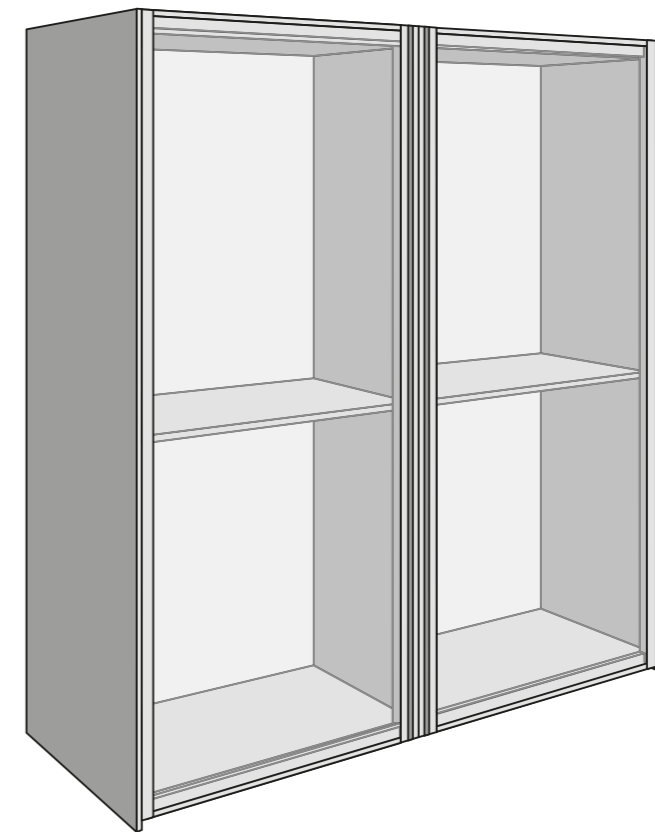
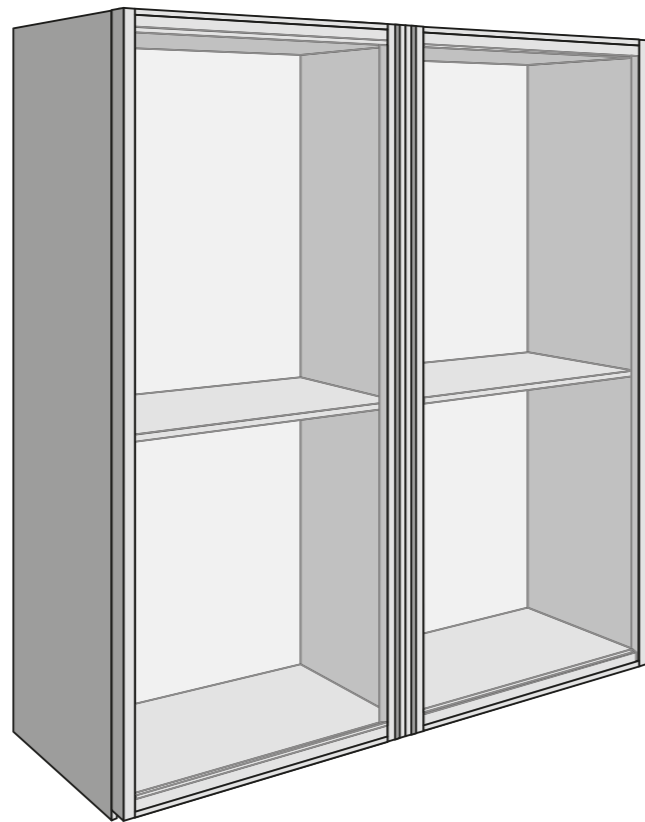
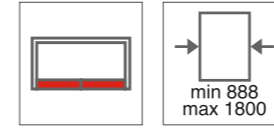

**ABBREVIAZIONI:**  
**LB** = larghezza binario  
**WA** = larghezza anta  
**S** = sormonto

**ABBREVIATIONS:**  
**LB** = rail length  
**WA** = door width  
**S** = overlapping

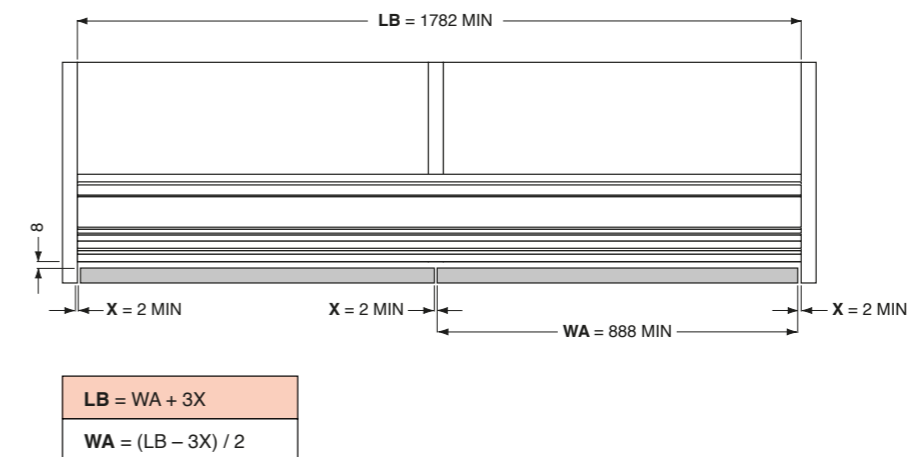
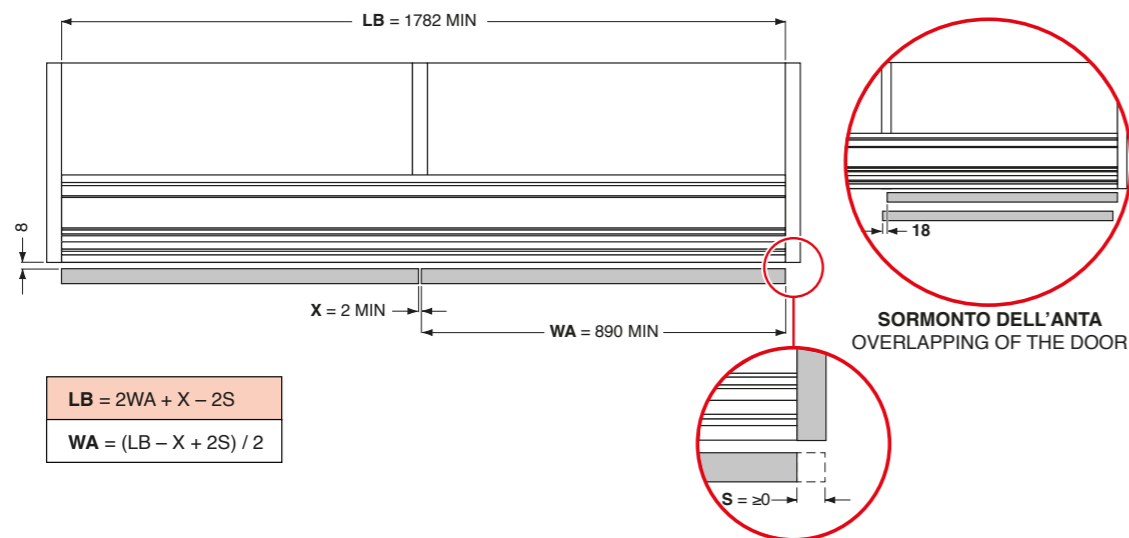

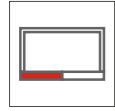

**Il riferimento iniziale per effettuare le fresature è sempre il centro dell'anta, qualsiasi sia la sua larghezza.**  
 The starting reference for milling the doors is always the central axle of the door, whatever its width is.

1

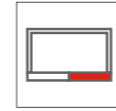
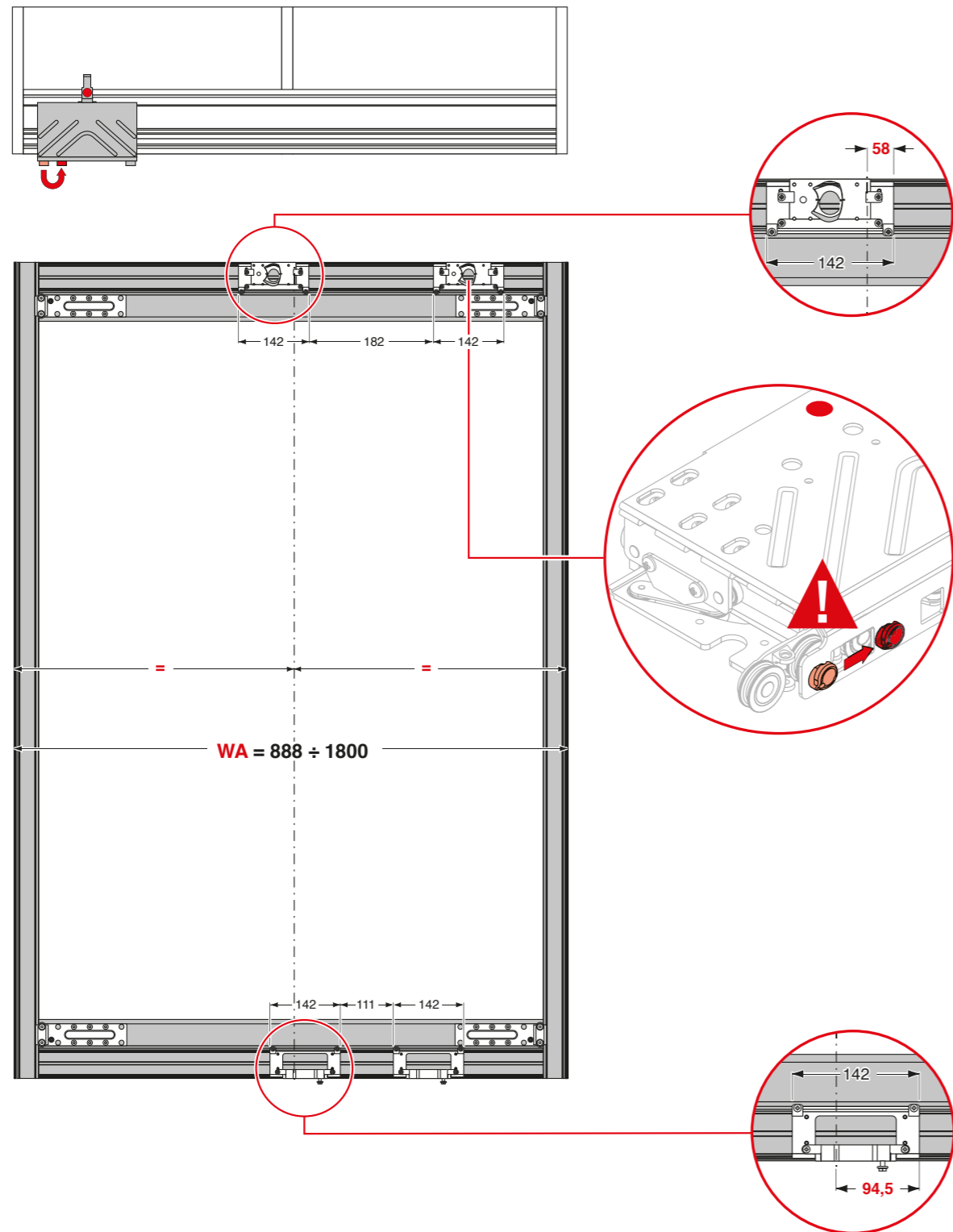

**Il riferimento iniziale per effettuare le fresature è sempre il centro dell'anta, qualsiasi sia la sua larghezza.**  
 The starting reference for milling the doors is always the central axle of the door, whatever its width is.

2

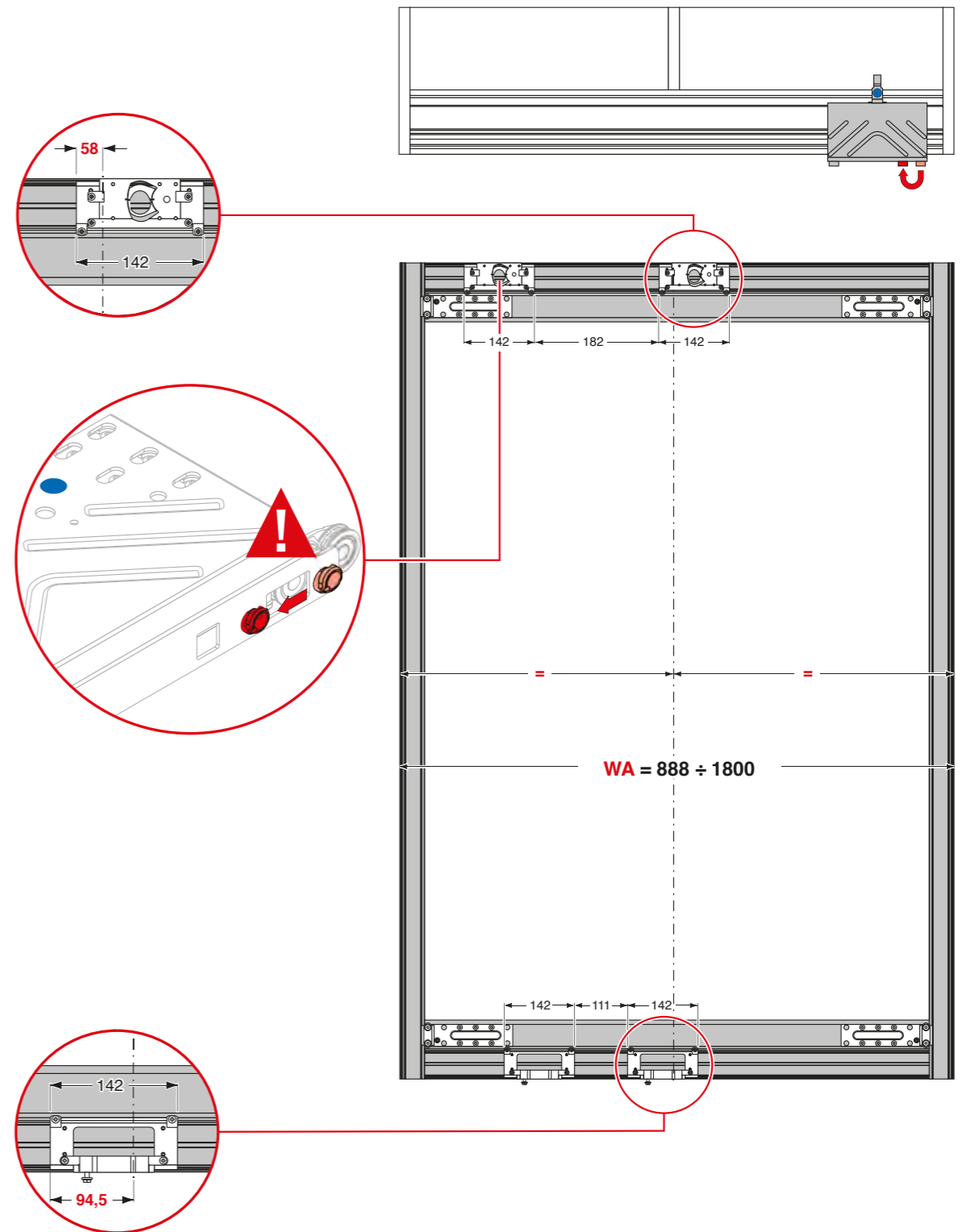

# PS19.5

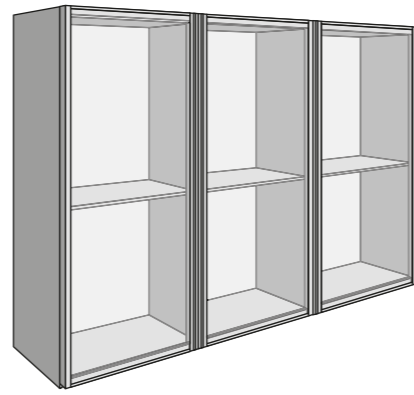
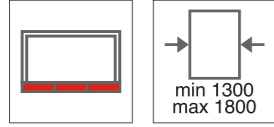

## PS19.5. Schede tecniche / Data sheets

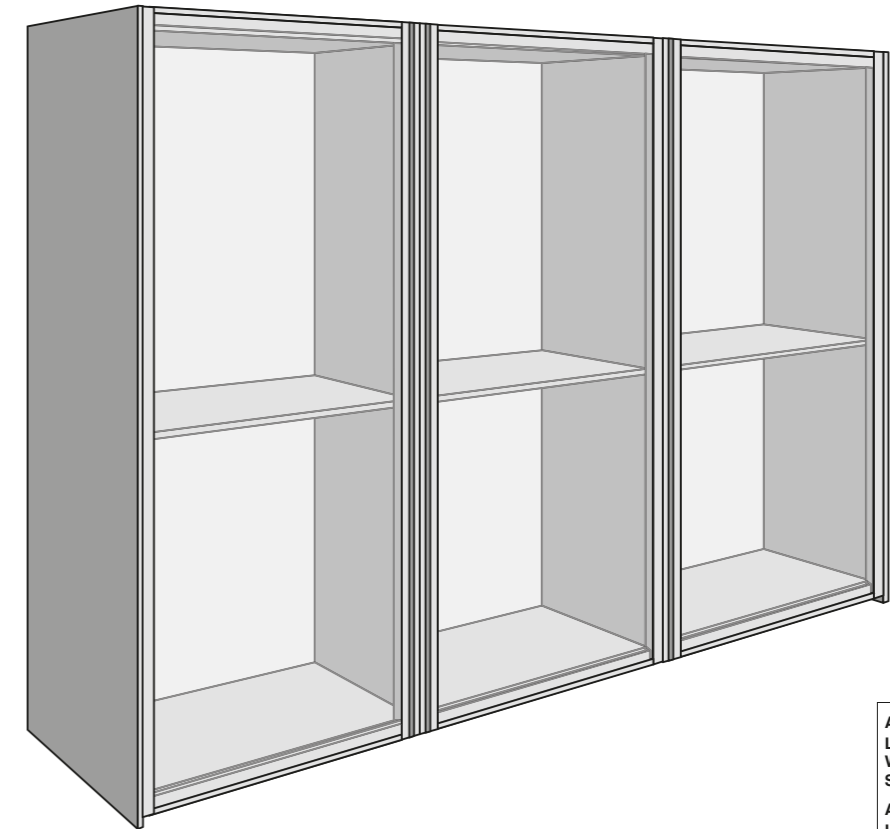
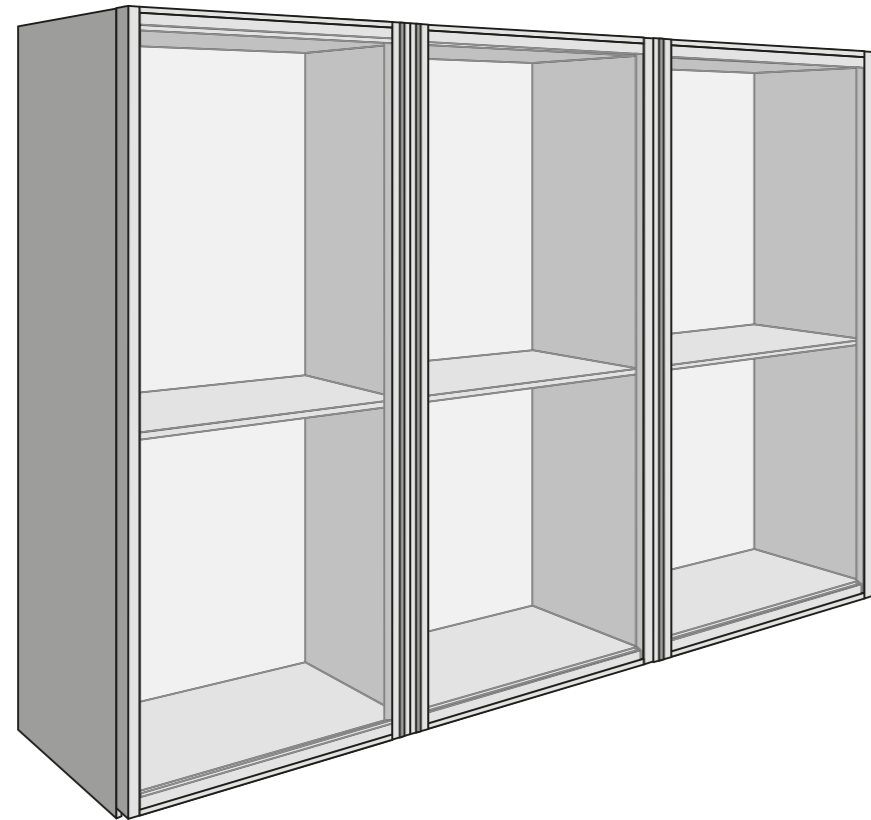

**ABBREVIAZIONI:**  
**LB** = larghezza binario  
**WA** = larghezza anta  
**S** = sormonto

**ABBREVIATIONS:**  
**LB** = rail length  
**WA** = door width  
**S** = overlapping

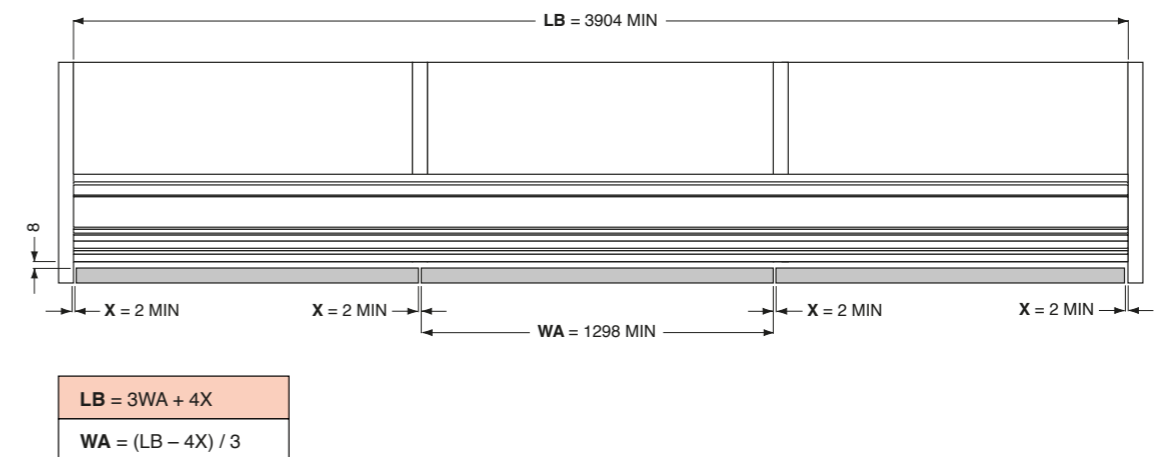
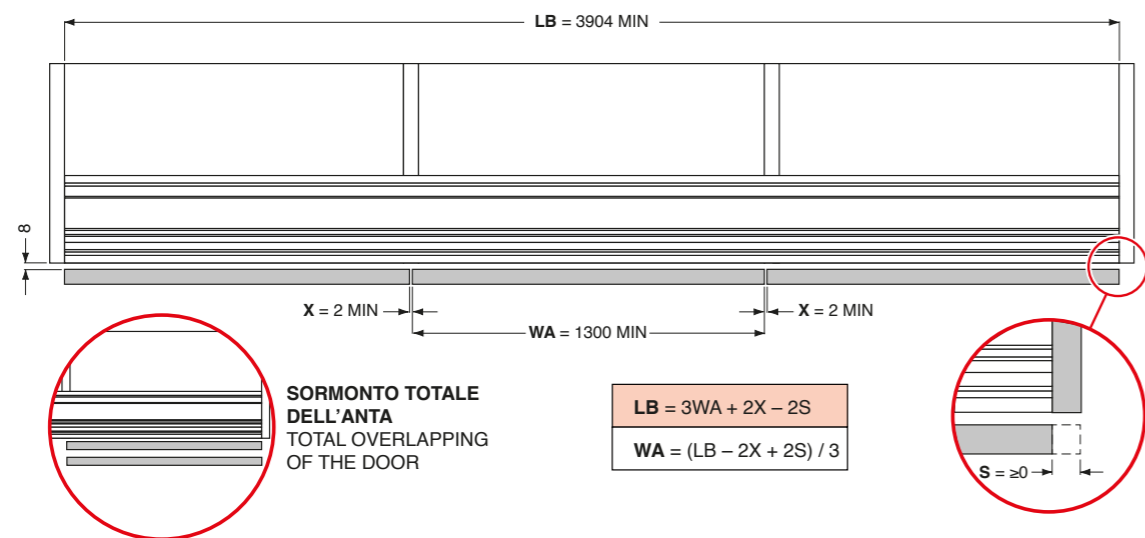



**Il riferimento iniziale per effettuare le fresature è sempre il centro dell'anta, qualsiasi sia la sua larghezza.**  
 The starting reference for milling the doors is always the central axle of the door, whatever its width is.

1

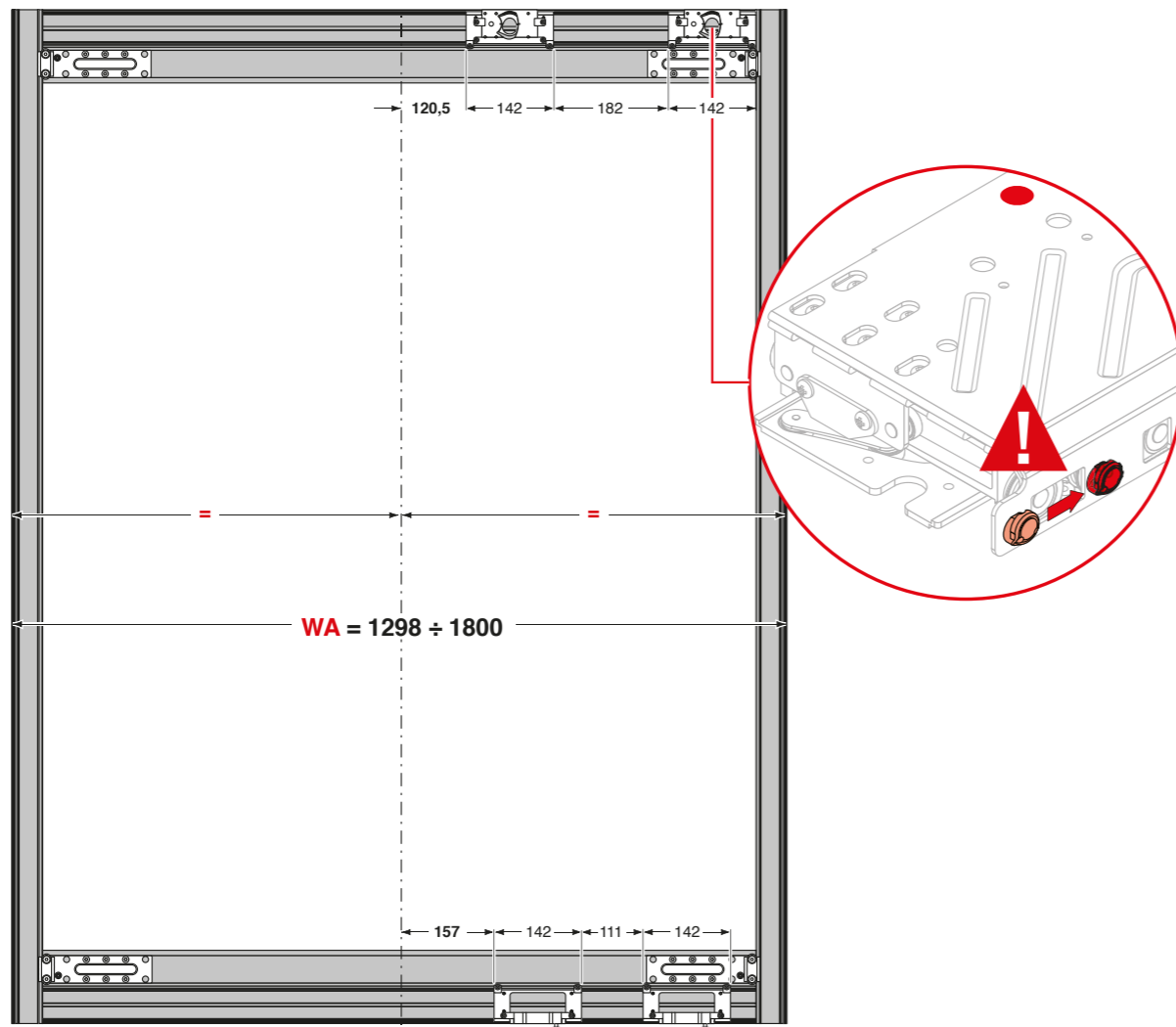

**Il riferimento iniziale per effettuare le fresature è sempre il centro dell'anta, qualsiasi sia la sua larghezza.**  
 The starting reference for milling the doors is always the central axle of the door, whatever its width is.

2

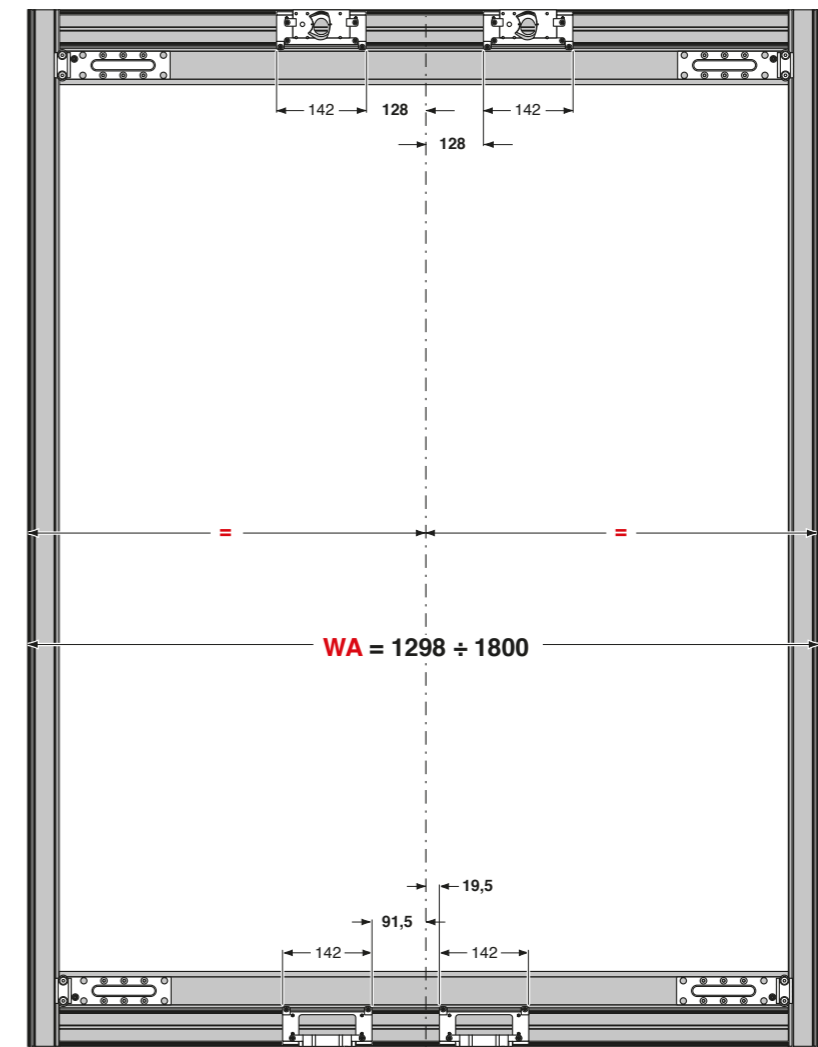

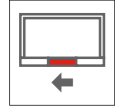

**Il riferimento iniziale per effettuare le fresature è sempre il centro dell'anta, qualsiasi sia la sua larghezza.**  
 The starting reference for milling the doors is always the central axle of the door, whatever its width is.

3

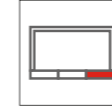
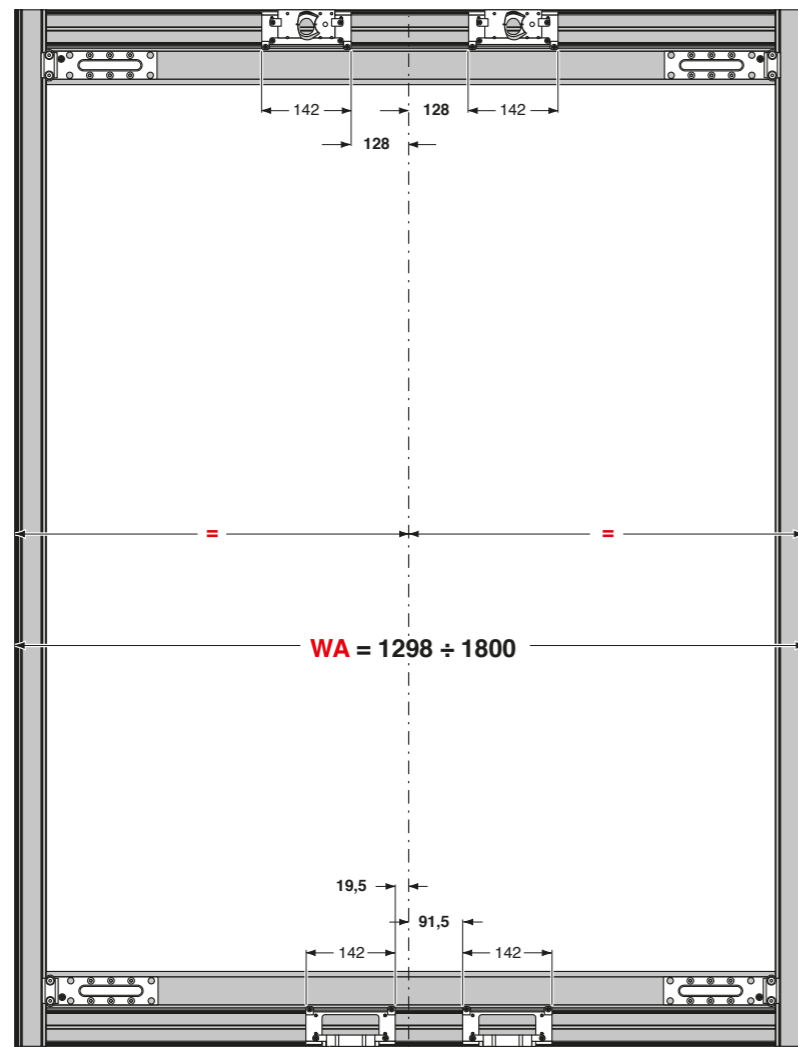

**Il riferimento iniziale per effettuare le fresature è sempre il centro dell'anta, qualsiasi sia la sua larghezza.**  
 The starting reference for milling the doors is always the central axle of the door, whatever its width is.

4

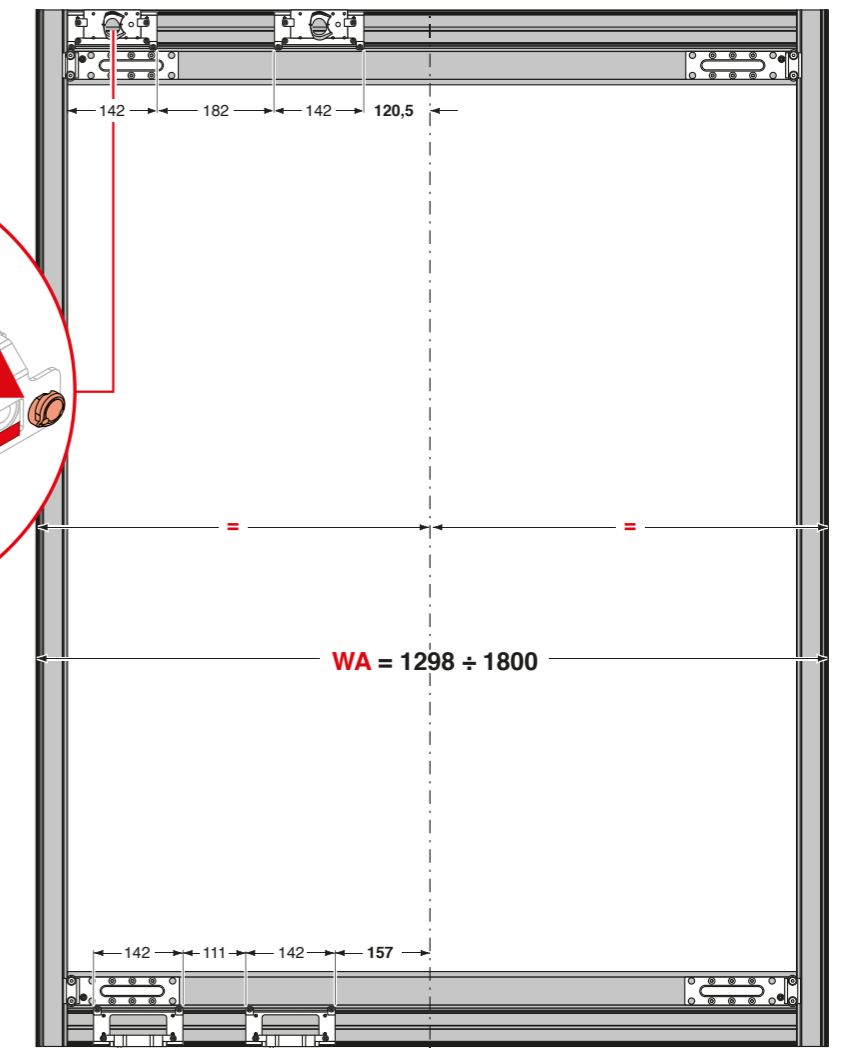
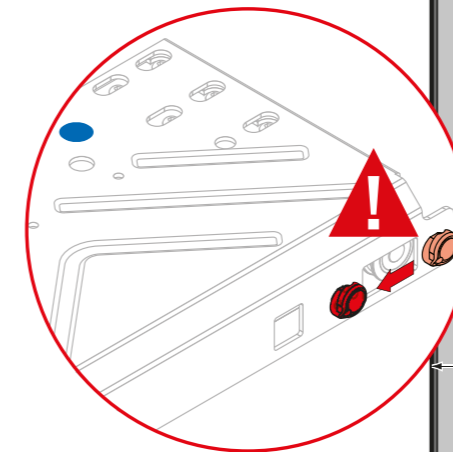

# PS19.5

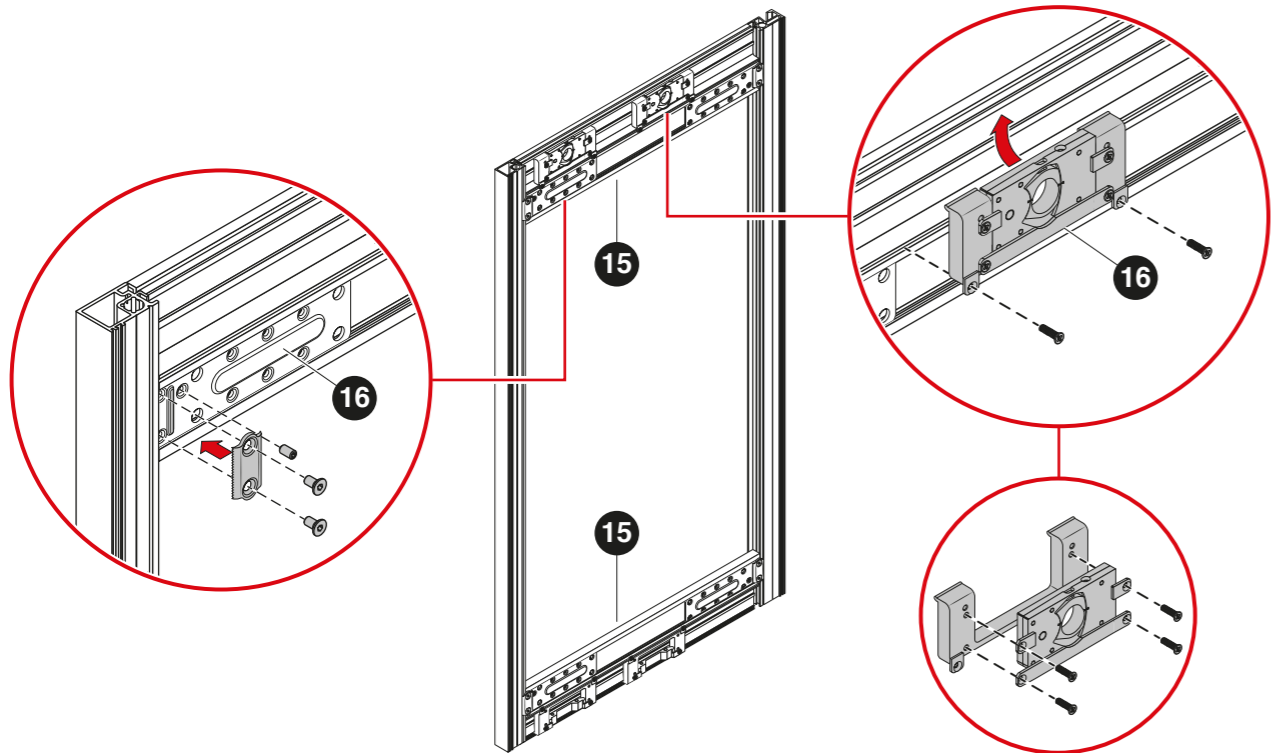
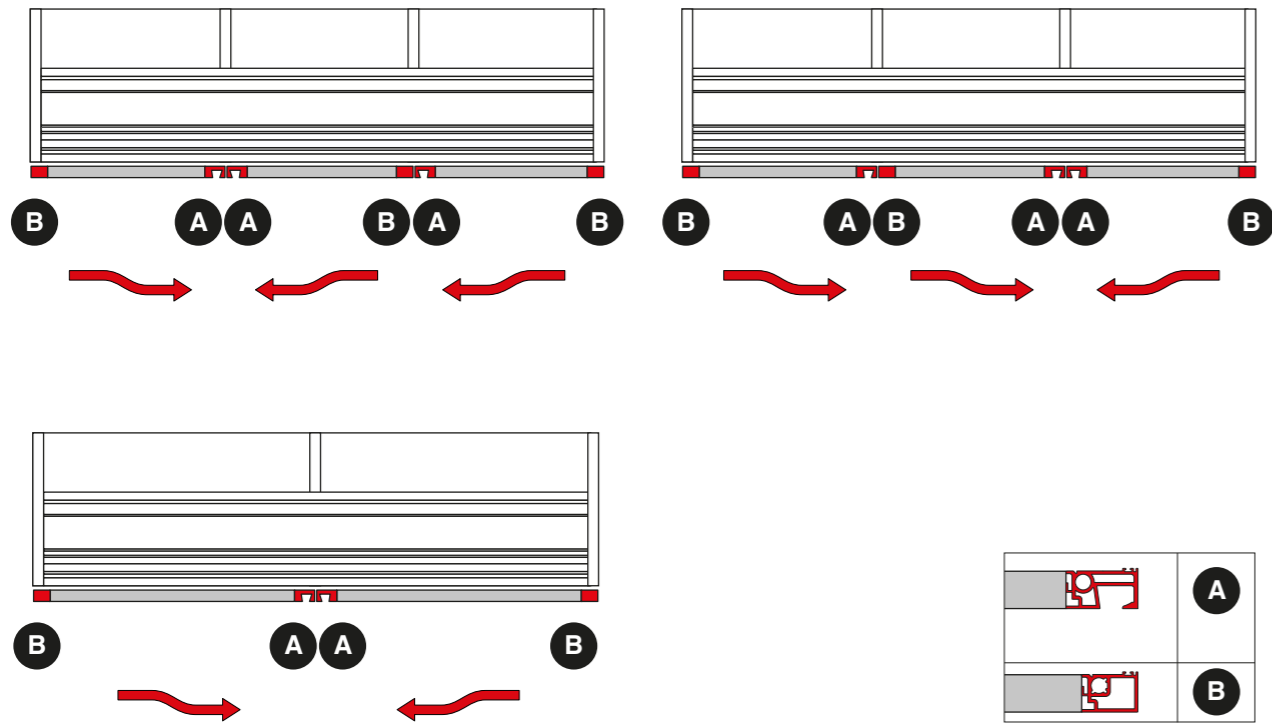
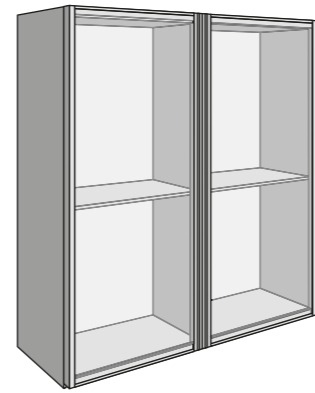

## PS19.5. Lista componenti / Parts list

### PR19700031A

Profilo montante verticale maniglia.

Vertical rod handle profile.

**Finiture standard / standard finishes**  
 Anodizzato / anodized: Silver  
 Verniciato / painted: Deep black, Metal grey, Moonlight

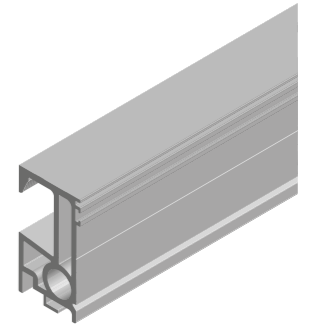
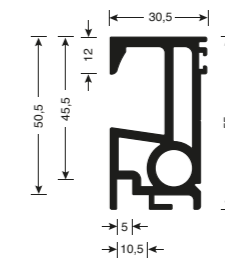

### PR19700032A

Profilo montante verticale.

Vertical rod profile.

**Finiture standard / standard finishes**  
 Anodizzato / anodized: Silver  
 Verniciato / painted: Deep black, Metal grey, Moonlight

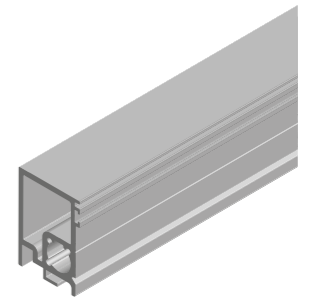
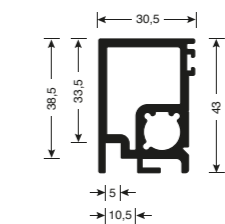

### PR19700030A

Profilo trasverso superiore - inferiore.

Upper - lower horizontal profile.

**Finiture standard / standard finishes**  
 Anodizzato / anodized: Silver  
 Verniciato / painted: Deep black, Metal grey, Moonlight

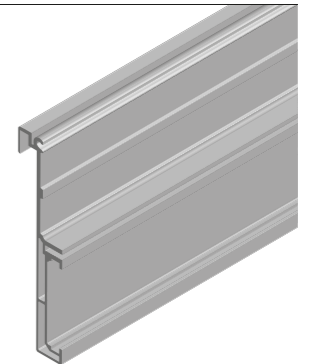
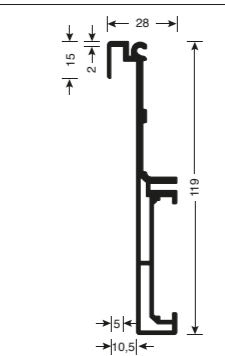

### PS19KS1005

Confezione per montaggio anta.  
 Finitura: Zincato + Grezzo

Kit for assembly door.  
 Finish: Zinc plated + Raw

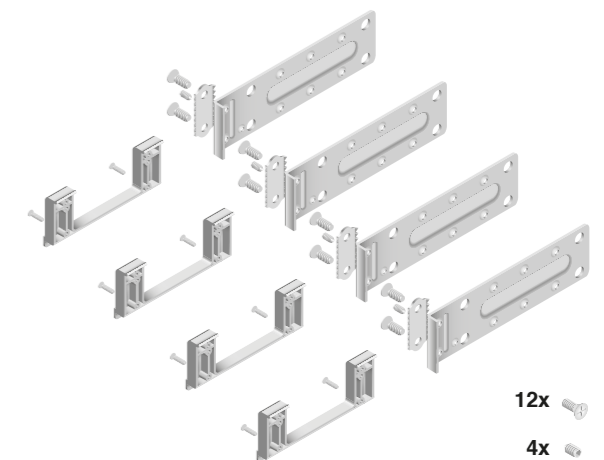

12x  
 4x



# PS19.5

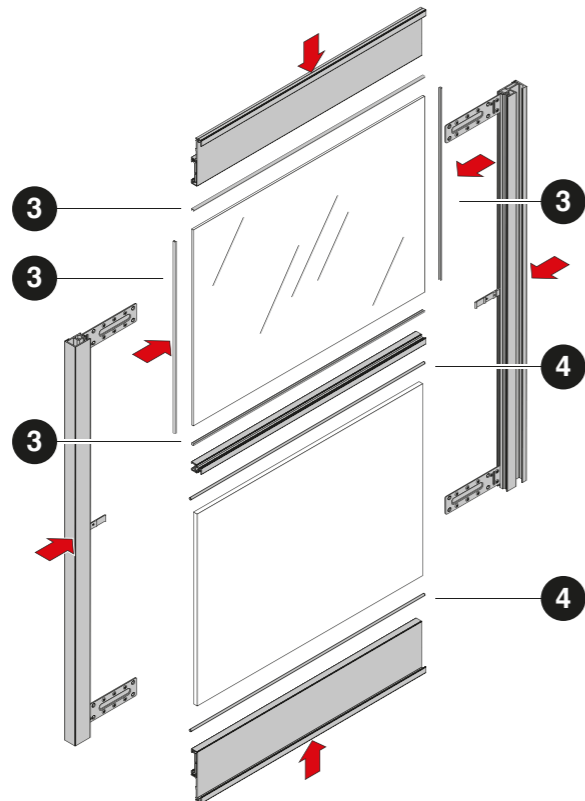
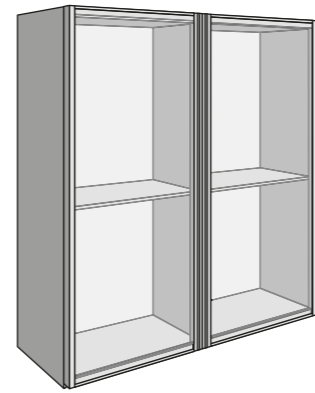
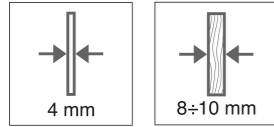

**ABBREVIAZIONI:**  
**WA** = larghezza anta  
**WP** = larghezza pannello  
**WG** = larghezza vetro  
**H1** = altezza anta  
**HP** = altezza pannello  
**HG** = altezza vetro

**ABBREVIATIONS:**  
**WA** = door width  
**WP** = panel width  
**WG** = glass width  
**H1** = door height  
**HP** = panel height  
**HG** = glass height

**PR20820002** Edge 0.8  
**PR20820004** Edge 0.6

Guarnizione per vetro.  
 Finitura: Neutro

Gasket for glass.  
 Finish: Neutral

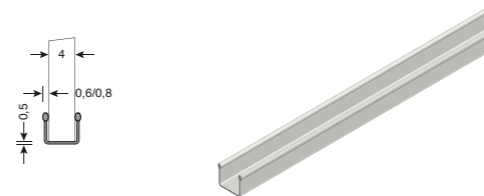

**TE238B0001**  
 Profilo tondo di compensazione Ø3 per pannello da 8 mm.  
 Finitura: Grigio

Round profile of compensation Ø3 for panel 8 mm.  
 Finish: Grey

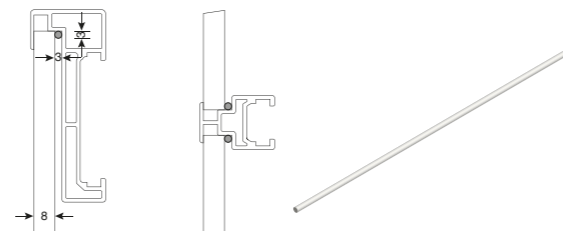

## PS19.5. Schede tecniche / Data sheets

### Calcolo dimensioni vetri e pannelli suddivisi in parti uguali.

Calculation of the dimensions of glasses and wooden panels divided in equal parts.

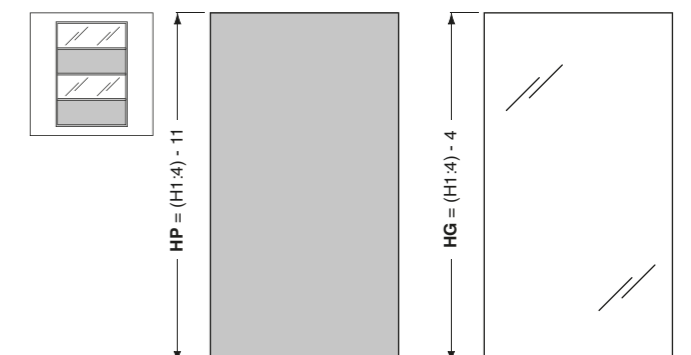
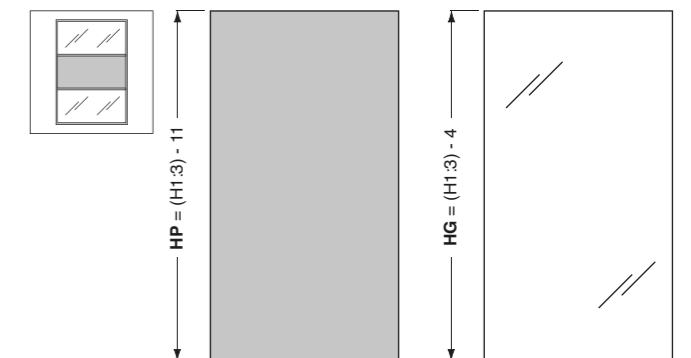
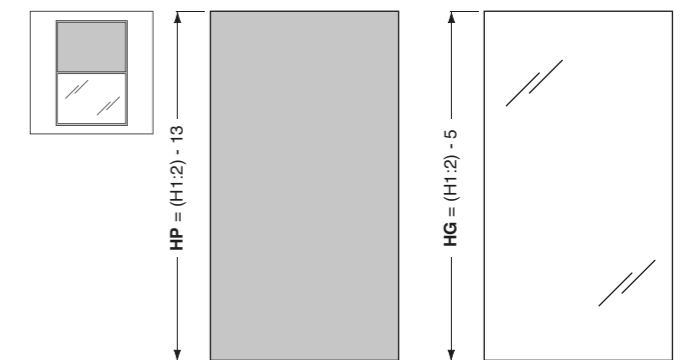
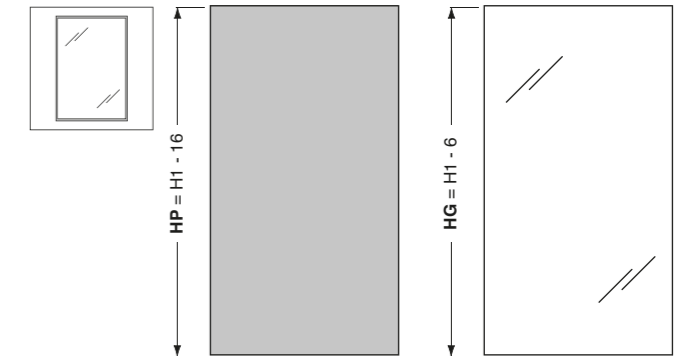
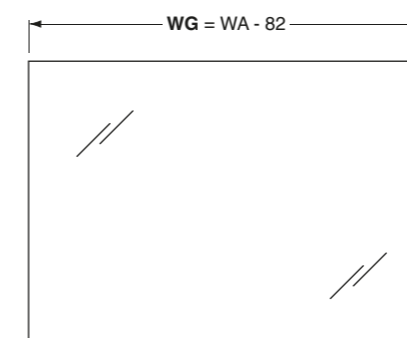
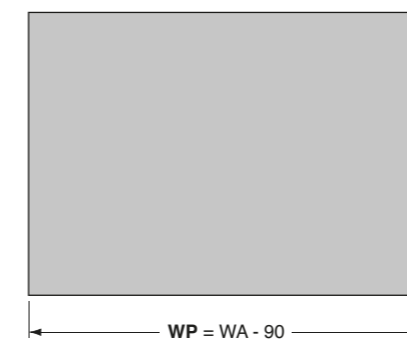
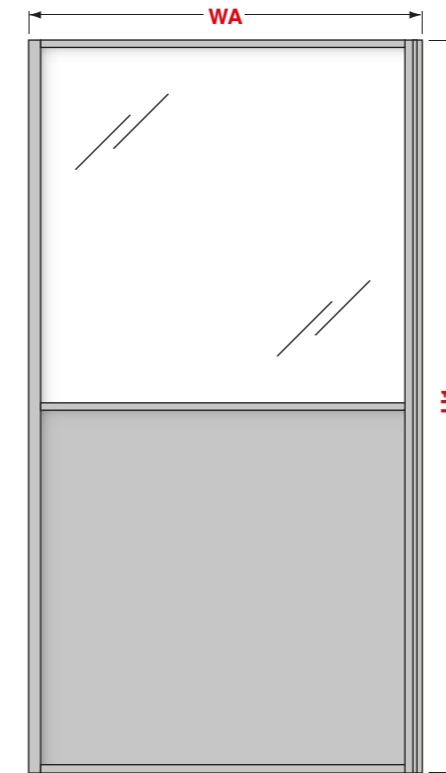

# PS19.5

option  
1

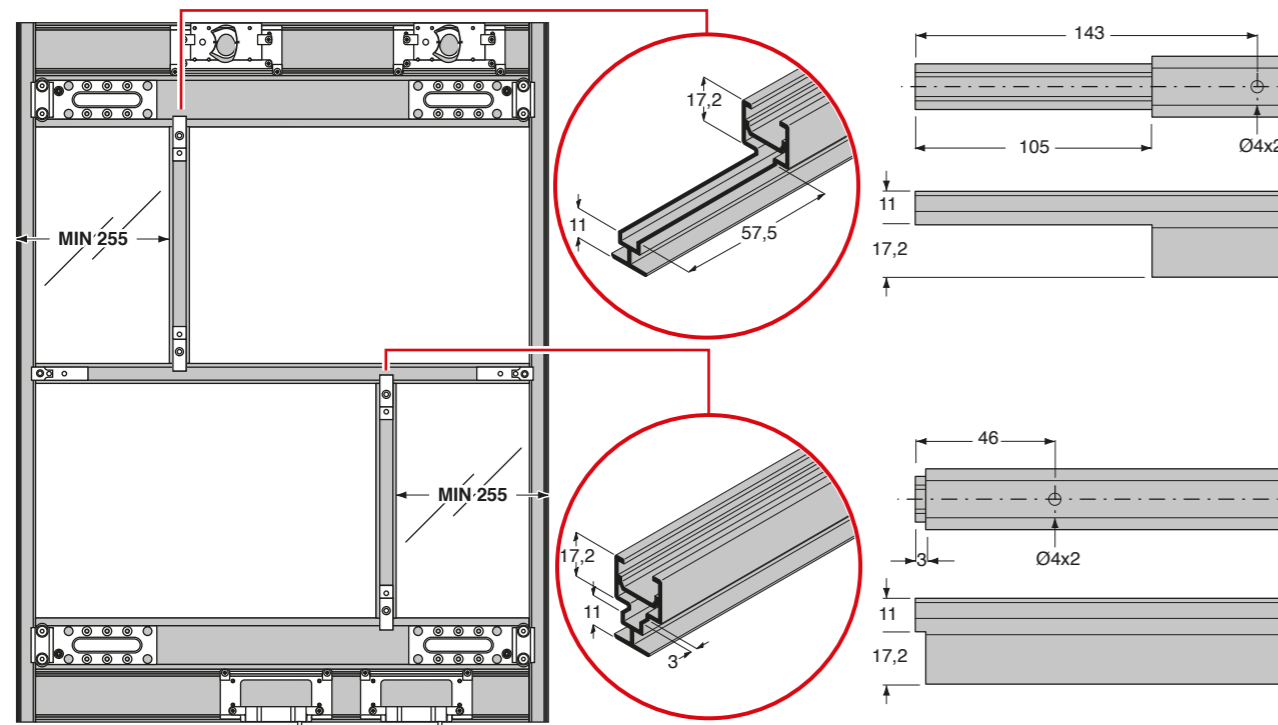
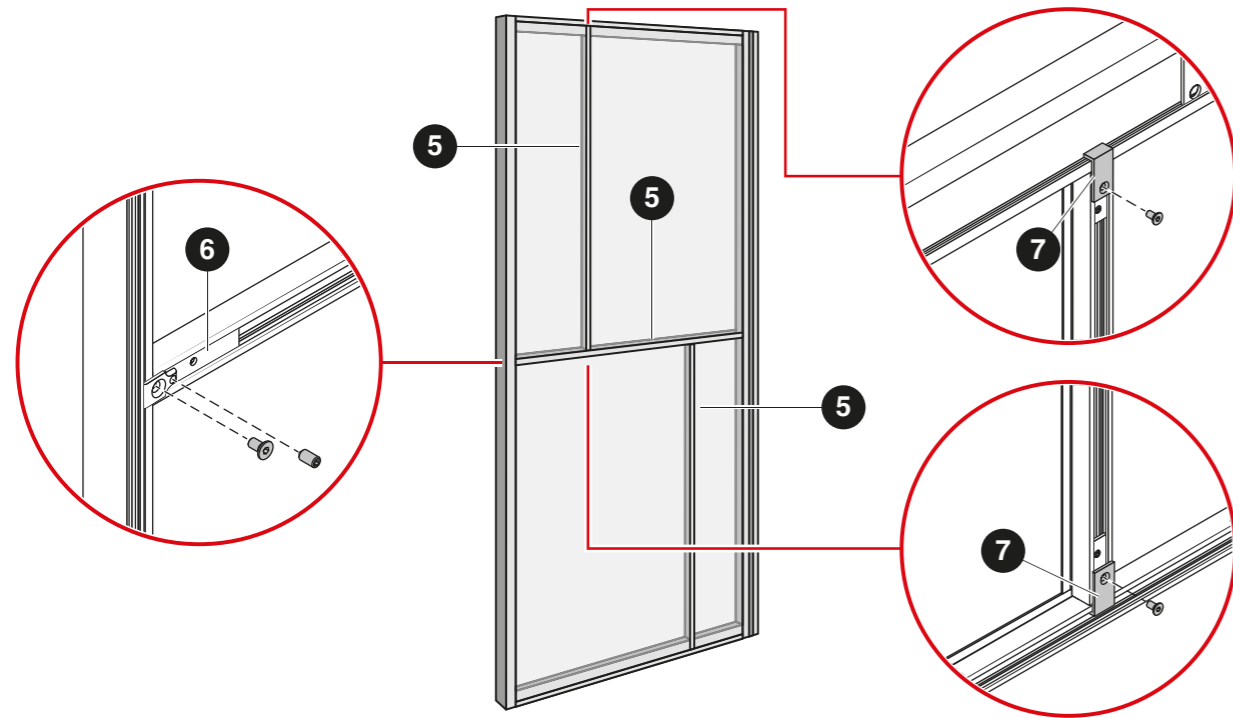
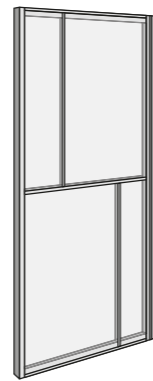

## PS19.5. Lista componenti / Parts list

### PR1970005A

Profilo traversino.

Cross profile.

**Finiture standard / standard finishes**

Anodizzato / anodized: Silver

Verniciato / painted: Deep black, Metal grey, Moonlight

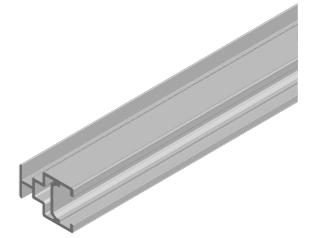
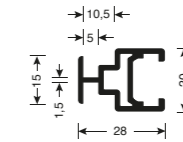

### PS19CS7212

Confezione per montaggio traversino orizzontale.

Finitura: Silver

Kit for assembly horizontal cross profile.

Finish: Silver

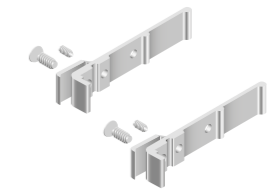

### PS19CS70020016

Confezione per montaggio traversino verticale.

Finitura: Silver

Kit for assembly vertical cross profile.

Finish: Silver

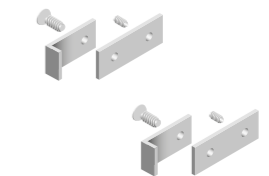

### PR20820002

Edge 0.8

### PR20820004

Edge 0.6

Guarnizione per vetro.

Finitura: Neutro

Gasket for glass.

Finish: Neutral

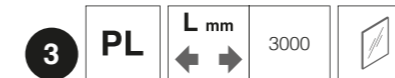
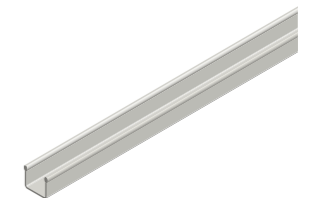
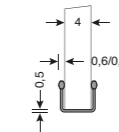

### TE238B0001

Profilo tondo di compensazione Ø3 per pannello da 8 mm.

Finitura: Grigio

Round profile of compensation Ø3 for panel 8 mm.

Finish: Grey

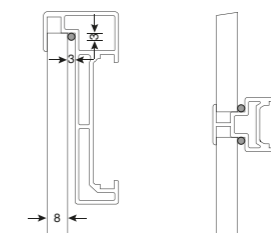



# PS19.5

option  
2

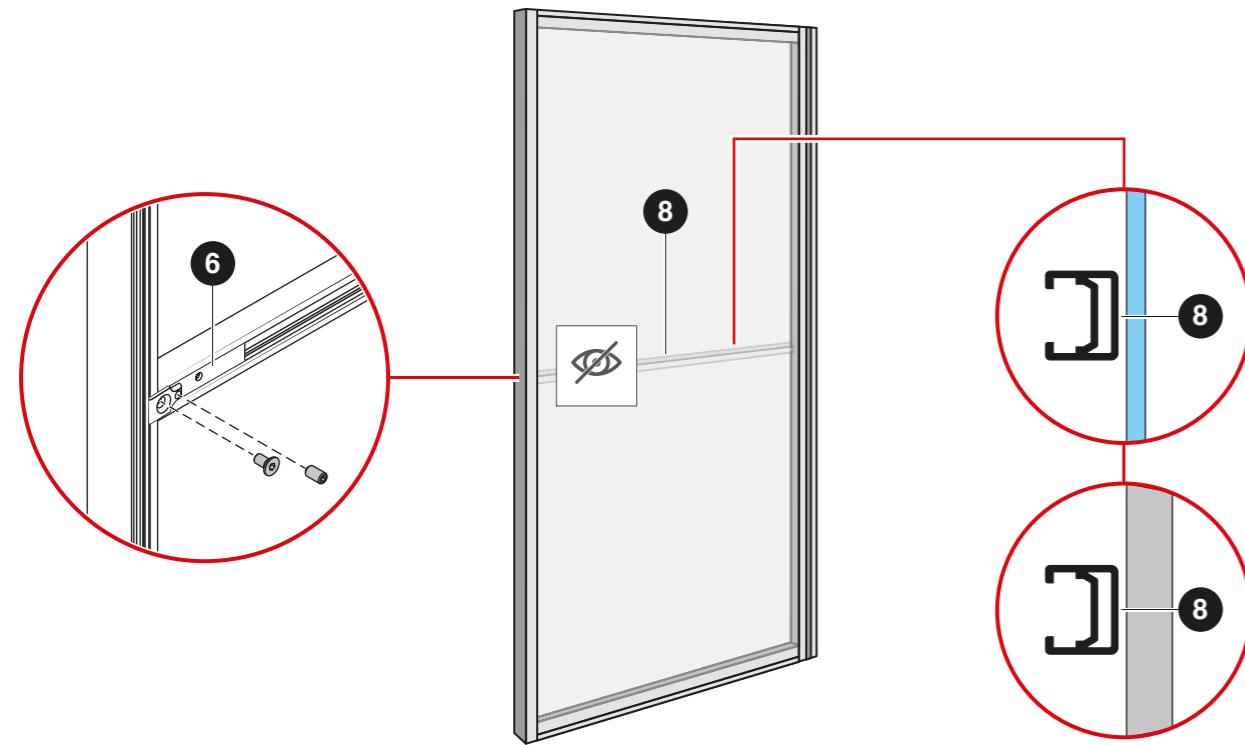
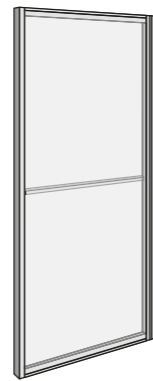

## PR1970021A

Profilo traversino senza sede vetro.

Cross profile without glass gasket seat.

### Finiture standard / standard finishes

Anodizzato / anodized: Silver  
Verniciato / painted: Deep black, Metal grey, Moonlight

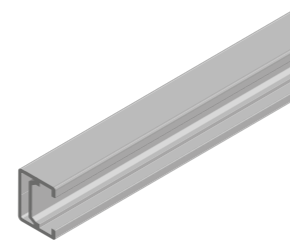
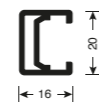

## PS19CS7212

Confezione per montaggio traversino orizzontale.

Finitura: Silver

Kit for assembly horizontal cross profile.

Finish: Silver

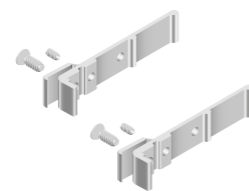

## PS19.5. Lista componenti / Parts list

### Accessori complementari

Additional accessories

#### PZ03480590A

Spazzolino parapolvere.  
Finitura: Nero

Save-dust brush.  
Finish: Black

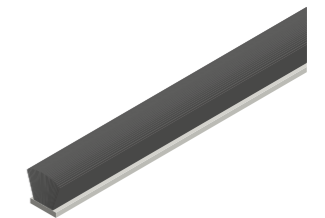
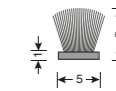

PL

#### BR

Raddrizza ante.

Doors straightener.

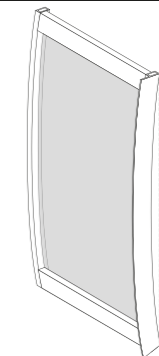



**Non utilizzare spray ed oli anti frizione o sblocca filetti sui cuscinetti o sulle ruote con O-ring dei pattini scorrevoli. Questo provoca lo scioglimento dei grassi dei cuscinetti rendendoli rumorosi oppure la rottura dell'O-ring.**  
Do not use any anti-friction oil or grease or thread-release spray on ball bearing or on wheels with O-ring, it can cause the melting of the inside ball bearing grease, making them noisy or causing the break of the O-ring of the wheels.

Tutte le parti del catalogo sono di proprietà della Cinetto F.Ili S.r.l.

È vietata qualsiasi imitazione e copia delle illustrazioni, della grafica e la riproduzione, anche parziale, del presente catalogo senza autorizzazione.

I disegni tecnici e le informazioni dimensionali, incluse le illustrazioni, riportate in questo catalogo non sono vincolanti. L'azienda si riserva il diritto di apportare modifiche a fini migliorativi.  
Tutte le dimensioni sono in mm, se non diversamente specificate.

Si declina ogni responsabilità per errori di stampa.

All constituents of the catalogue are the property of Cinetto F.Ili S.r.l.

Reprint of the catalogue or extracts thereof, including those in the illustrations and imitation of the design is forbidden without permission.

The technical representations and dimensional information in this catalogue are non-binding, including those in the illustrations and drawings. Right reserved to make design improvements.  
All dimensions are in mm unless otherwise specified.

No liability accepted for printing errors of the catalogue.

Rilasciato da - Issued by  
Cinetto F.Ili S.r.l.  
Via Meucci, 4 - 35030 Rubano (PD) Italy

Tel. +39 049 8977211 - Fax +39 049 635822

Internet: [www.cinetto.it](http://www.cinetto.it) - Email: [info@cinetto.it](mailto:info@cinetto.it)

Aprile 2023  
© by Cinetto F.Ili S.r.l.  
All rights reserved.  
Printed in Padova - Italy



**Sede Legale e Officina di Produzione**

Via Meucci, 4 - 35030 Rubano (PD) Italy

[www.cinetto.it](http://www.cinetto.it) - [info@cinetto.it](mailto:info@cinetto.it)

**Sede Amministrativa, Magazzino e Punto Vendita**

Via Rossi, 5/A - 35030 Rubano (PD) Italy

Tel. +39 049 8977211 - Fax +39 049 635822

C.F./P.I. (VAT) (IT) 00277120283

