

TIOMOS 110

110° hinge (door thicknesses up to 24 mm)

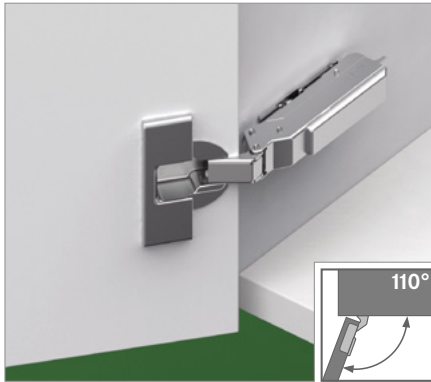

- 110° opening angle
- Optimal reveals for door thicknesses up to 24 mm
- With convenient depth adjustment via worm screw
- 3-dimensional adjustment with corresponding mounting plate
- Surfaces: Nickel or Night (especially for dark cabinet materials and woods)

Available in four versions:

- With integrated damper (3 adjustable damping levels)
- Without integrated damper
- Without self-closing mechanism (without spring)
- With self-opening mechanism



ORDER INFORMATION FOR DRILLING PATTERN 45/9.5, NICKEL

Door overlay	Cranking	Damper		Without spring	With self-opening mechanism ³	Art. No.		
		With	Without			Click-on for screw fitting	Click-on for press fitting	Impresso tool-free
Full overlay ¹	0	■	-	-	-	F028138519	F028138523	F017139329
		-	■	-	-	F045138457	F045138461	F034139300
		-	■	■	-	F046138579	-	F035139357
Overlay ¹	3	■	-	-	-	F028138520	F028138524	F017139330
		-	■	-	-	F045138458	F045138462	F034139301
		-	■	■	-	F046138580	F046138584	F035139358
		-	-	-	■	F046140360	-	-
Half overlay ²	9.5	■	-	-	-	F028138521	F028138525	F017139331
		-	■	-	-	F045138459	F045138463	F034139302
		-	■	■	-	F046138581	F046138585	F035139359
		-	-	-	■	F046140365	-	-
Inset ²	19	■	-	-	-	F028138522	F028138526	F017139332
		-	■	-	-	F045138460	F045138464	F034139303
		-	■	■	-	F046138582	F046138586	F035139360
		-	-	-	■	F046140366	-	-

¹ Cup material: steel, nickel-plated/Arm material: steel, nickel-plated

² Cup material: steel, nickel-plated/Arm material: zamak, nickel-plated

³ Additional Tipmatic Plus Pin required

ORDER INFORMATION FOR DRILLING PATTERN 45/9.5, NIGHT

Door overlay	Cranking	Damper		Without spring		Art. No.		
		With	Without			Click-on for screw fitting		
Overlay ¹	3	■	-	-		F028139129		
		-	■	-		F045140958		
		-	■	■		F046149603		
Half overlay ²	9.5	■	-	-		F028139130		
		-	■	-		F045140952		
		-	■	■		F046149604		
Inset ²	19	■	-	-		F028139131		
		-	■	-		F045140955		
		-	■	■		F046149605		

¹ Cup material: steel, Night/Arm material: steel, Night

² Cup material: steel, Night/Arm material: zamak, Night

PAGE REFERENCES

Tiomos mounting plates	86	Tipmatic	114		
Accessories	96	Assembly technology	637		
Technical information	100	Assembly aids	654		

PLANNING DIMENSIONS

All dimensions in millimetres

Full overlay K0		Overlay K3		Half overlay K9.5		Inset ¹ K19							
Mounting plate height 2		Mounting plate height 2		Mounting plate height 2		Mounting plate height 2 ¹ Set mounting plate back by door thickness + 1.5 mm							
Door overlay	0 Cup distance	3	4	5	6	7	Door reveal	19 Cup distance	3	4	5	6	7
	24.0					-2		0.0		0		2	3
	23.0				-2			0.5					
	22.0			-2		0		1.0	0		2	3	
	21.0		-2			0		1.5					
	20.0	-2				2		2.0		2	3		
	19.0					2		3	3.0	2	3		
	18.5							4.0	3				
	18.0	0				2		3					
	17.5												
	17.0		2	3									
	16.5												
	16.0	2	3										
15.5													
15.0	3												
	Mounting plate height							Mounting plate height					

MINIMUM GAP

Door thickness	Cup distance					
	3	4	5	6	7	
	24.0	1.0	1.0	1.0	1.2 ²	2.1 ²
	22.0	1.0	1.0	1.0	1.0	1.5 ²
	21.0	1.0	1.0	1.0	1.0	1.2 ²
	20.0	1.0	1.0	1.0	1.0	1.0
	19.0	1.0	1.0	1.0	1.0	1.0
	18.0	1.0	1.0	1.0	1.0	1.0
	17.0	1.0	1.0	1.0	1.0	1.0
16.0	1.0	1.0	1.0	1.0	1.0	

Minimum gap

² 1.0 with 85° opening angle

MINIMUM REVEAL

Door thickness	Cup distance					
	3	4	5	6	7	
	24.0	2.4	2.1	2.1	2.1	2.0
	22.0	1.6	1.6	1.6	1.5	1.5
	21.0	1.4	1.3	1.3	1.3	1.3
	20.0	1.1	1.1	1.1	1.1	1.1
	19.0	0.9	0.9	0.9	0.9	0.9
	18.0	0.7	0.7	0.7	0.7	0.7
	17.0	0.6	0.6	0.6	0.6	0.6
16.0	0.6	0.6	0.6	0.6	0.6	

Minimum reveal (F)

85° OPENING ANGLE

Door thickness	Cup distance					
	3	4	5	6	7	
	36.0	11.1	10.3	9.7	9.1	8.5
	30.0	5.4	4.8	4.4	4.3	4.2
	28.0	3.7	3.6	3.5	3.4	3.3
	26.0	2.9	2.8	2.8	2.7	2.6
	24.0	2.2	2.1	2.1	2.1	2.0
	22.0	1.6	1.6	1.6	1.5	1.5
	21.0	1.4	1.3	1.3	1.3	1.3
20.0	1.1	1.1	1.1	1.1	1.1	
19.0	0.9	0.9	0.9	0.9	0.9	
18.0	0.7	0.7	0.7	0.7	0.7	
16.0	0.6	0.6	0.6	0.6	0.6	

Minimum reveal (F)³ at 85°

³ 85° opening angle reduction clip

NOTES

The minimum gap is the clearance required between the cabinet face and the closed door so that the door can be opened without hindrance.

Minimum reveal for doors with chamfered edges (R = 1 mm) with factory setting.

A trial fitting is recommended for door thicknesses from 24 mm.

DRILLING PATTERNS 45/9.5

For screw fitting	For press fitting	Impresso combination drilling pattern

CUP DIMENSIONS

() Impresso

TIOMOS 120

120° hinge (door thicknesses up to 24 mm)



- 120° opening angle
- Optimal reveals for door thicknesses up to 22 mm
- With convenient depth adjustment via worm screw
- 3-dimensional adjustment with corresponding mounting plate

Available in three versions:

- With integrated damper (3 adjustable damping levels)
- Without integrated damper
- Without self-closing mechanism (without spring)

ORDER INFORMATION FOR DRILLING PATTERN 45/9.5, NICKEL

Door overlay		Cranking	Damper		Without spring	Art. No.		
			With	Without		Click-on for screw fitting	Click-on for press fitting	Impresso tool-free
Full overlay ¹		0	■	-	-	F028 138547	F028 138551	F017 139343
			-	■	-	F045 138485	F045 138489	F034 139314
			-	■	■	F046 138607	F046 138611	F035 139371
Overlay ¹		3	■	-	-	F028 138548	F028 138552	F017 139344
			-	■	-	F045 138486	F045 138490	-
			-	■	■	F046 138608	F046 138612	-
Half overlay ²		9.5	■	-	-	F028 138549	F028 138553	F017 139345
			-	■	-	F045 138487	F045 138491	F034 139316
			-	■	■	F046 138609	F046 138613	F035 139373
Inset ²		19	■	-	-	F028 138550	F028 138554	F017 139346
			-	■	-	F045 138488	F045 138492	F034 139317
			-	■	■	F046 138610	F046 138614	F035 139374

¹ Cup material: steel, nickel-plated/Arm material: steel, nickel-plated

² Cup material: steel, nickel-plated/Arm material: zamak, nickel-plated

PAGE REFERENCES

Tiomos mounting plates	86	Tipmatic	114		
Accessories	96	Assembly technology	637		
Technical information	100	Assembly aids	654		

TIOMOS 155

155° wide-angle hinge (door thicknesses up to 32 mm)

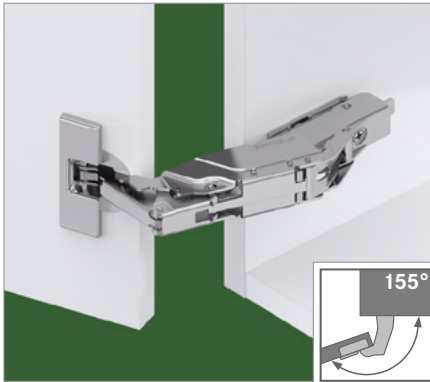

- 155° opening angle
- With convenient depth adjustment via worm screw
- For cabinets with inset drawers or pull-out shelves
- Optimal reveals for door thicknesses up to 32 mm
- 3-dimensional adjustment with corresponding mounting plate
- Minimum reveals
- Shallow cup depth
- Surfaces: Nickel or Night (especially for dark cabinet materials and woods)

Available in three versions:

- With integrated damper (3 adjustable damping levels)
- Without integrated damper
- Without self-closing mechanism (without spring)

ORDER INFORMATION FOR DRILLING PATTERN 45/9.5, NICKEL

Door overlay	Cranking	Damper		Without spring	Art. No.		
		With	Without		Click-on for screw fitting	Click-on for press fitting	Impresso tool-free
Full overlay ¹	0	■	-	-	F028 138561	F028 138564	F017 139350
		-	■	-	F045 138499	F045 138502	F034 139321
		-	■	■	F046 138621	F046 138624	-
Overlay ¹	3	■	-	-	F028 138562	F028 138565	F017 139351
		-	■	-	F045 138500	F045 138503	F034 139322
		-	■	■	F046 138622	F046 138625	-
Half overlay ¹	9.5	■	-	-	F028 138563	F028 138566	F017 139352
		-	■	-	F045 138501	F045 138504	F034 139323
		-	■	■	F046 138623	F046 138626	F035 139380

¹ Cup material: zamak, nickel-plated/Arm material: zamak, nickel-plated

ORDER INFORMATION FOR DRILLING PATTERN 45/9.5, NIGHT

Door overlay	Cranking	Damper		Without spring	Art. No.		
		With	Without		Click-on for screw fitting		
Overlay ¹	3	■	-	-	F028 140944		
Half overlay ¹	9.5	■	-	-	F028 140942		

¹ Cup material: zamak, Night/Arm material: zamak, Night

MITRED APPLICATION (ON ALL SIDES)

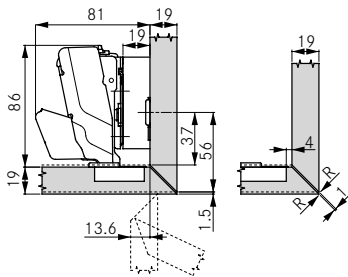

With 0 cranking, mounting plate height 19 mm and cup distance 4 mm, door and cabinet edges can meet at mitred angles on all 4 sides.

ZERO PROTRUSION

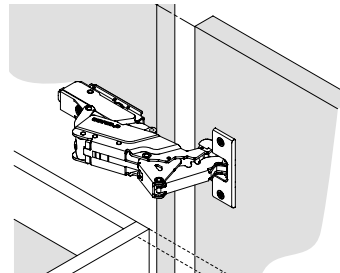

For use with inset drawers.

At 0 cranking, and with all mounting plate thicknesses, the door protrudes inwards at 90°. With cranking size 3 and mounting plate height 3 mm, the door will be flush with the cabinet.

Door thickness (TS)	Mitre, all 4 sides	Mitre, side
	R (min.)	R (min.)
19-20	1.0	0
22	2.0	0
24	3.0	1.0
26	4.2	2.5
28	5.4	3.8
30	6.5	5.3

PLANNING DIMENSIONS

All dimensions in millimetres

Full overlay	K0	Overlay	K3	Half overlay	K9.5	Inset ¹	K0																																																																																																																																																																																																																																																																																																																																																																																																																																																																																																																
Mounting plate height 2	Mounting plate height 2	Mounting plate height 2	Mounting plate height 2			Cranking 0, mounting plate height 21																																																																																																																																																																																																																																																																																																																																																																																																																																																																																																																	
							¹ Set mounting plate back by door thickness + 1.5 mm																																																																																																																																																																																																																																																																																																																																																																																																																																																																																																																
<table border="1"> <thead> <tr> <th rowspan="2">Door overlay</th> <th colspan="8">Cup distance</th> </tr> <tr> <th>3</th> <th>4</th> <th>5</th> <th>6</th> <th>7</th> <th>8</th> <th></th> <th></th> </tr> </thead> <tbody> <tr><td>25.0</td><td></td><td></td><td></td><td></td><td></td><td>-2</td><td></td><td></td></tr> <tr><td>24.0</td><td></td><td></td><td></td><td></td><td>-2</td><td></td><td></td><td></td></tr> <tr><td>23.0</td><td></td><td></td><td></td><td>-2</td><td></td><td>0</td><td></td><td></td></tr> <tr><td>22.0</td><td></td><td></td><td>-2</td><td></td><td>0</td><td></td><td></td><td></td></tr> <tr><td>21.0</td><td></td><td>-2</td><td></td><td>0</td><td>2</td><td></td><td></td><td></td></tr> <tr><td>20.0</td><td>-2</td><td></td><td>0</td><td>2</td><td>3</td><td></td><td></td><td></td></tr> <tr><td>19.0</td><td></td><td>0</td><td>2</td><td>3</td><td></td><td></td><td></td><td></td></tr> <tr><td>18.5</td><td></td><td></td><td></td><td></td><td></td><td></td><td></td><td></td></tr> <tr><td>18.0</td><td>0</td><td>2</td><td>3</td><td></td><td></td><td></td><td></td><td></td></tr> <tr><td>17.5</td><td></td><td></td><td></td><td></td><td></td><td></td><td></td><td></td></tr> <tr><td>17.0</td><td>2</td><td>3</td><td></td><td></td><td></td><td></td><td></td><td></td></tr> <tr><td>16.5</td><td></td><td></td><td></td><td></td><td></td><td></td><td></td><td></td></tr> <tr><td>16.0</td><td>2</td><td>3</td><td></td><td></td><td></td><td></td><td></td><td></td></tr> <tr><td>15.5</td><td></td><td></td><td></td><td></td><td></td><td></td><td></td><td></td></tr> <tr><td>15.0</td><td>3</td><td></td><td></td><td></td><td></td><td></td><td></td><td></td></tr> </tbody> </table>	Door overlay	Cup distance								3	4	5	6	7	8			25.0						-2			24.0					-2				23.0				-2		0			22.0			-2		0				21.0		-2		0	2				20.0	-2		0	2	3				19.0		0	2	3					18.5									18.0	0	2	3						17.5									17.0	2	3							16.5									16.0	2	3							15.5									15.0	3								<table border="1"> <thead> <tr> <th rowspan="2">Door overlay</th> <th colspan="8">Cup distance</th> </tr> <tr> <th>3</th> <th>4</th> <th>5</th> <th>6</th> <th>7</th> <th>8</th> <th></th> <th></th> </tr> </thead> <tbody> <tr><td>22.0</td><td></td><td></td><td></td><td></td><td></td><td>-2</td><td></td><td></td></tr> <tr><td>21.0</td><td></td><td></td><td></td><td></td><td>-2</td><td></td><td></td><td></td></tr> <tr><td>20.0</td><td></td><td></td><td></td><td>-2</td><td></td><td>0</td><td></td><td></td></tr> <tr><td>19.0</td><td></td><td></td><td>-2</td><td></td><td>0</td><td></td><td></td><td></td></tr> <tr><td>18.0</td><td></td><td>-2</td><td></td><td>0</td><td>2</td><td></td><td></td><td></td></tr> <tr><td>17.0</td><td>-2</td><td></td><td>0</td><td>2</td><td>3</td><td></td><td></td><td></td></tr> <tr><td>16.5</td><td></td><td></td><td></td><td></td><td></td><td></td><td></td><td></td></tr> <tr><td>16.0</td><td>0</td><td>2</td><td>3</td><td></td><td></td><td></td><td></td><td></td></tr> <tr><td>15.5</td><td></td><td></td><td></td><td></td><td></td><td></td><td></td><td></td></tr> <tr><td>15.0</td><td>0</td><td>2</td><td>3</td><td></td><td></td><td></td><td></td><td></td></tr> <tr><td>14.5</td><td></td><td></td><td></td><td></td><td></td><td></td><td></td><td></td></tr> <tr><td>14.0</td><td>2</td><td>3</td><td></td><td></td><td></td><td></td><td></td><td></td></tr> <tr><td>13.5</td><td></td><td></td><td></td><td></td><td></td><td></td><td></td><td></td></tr> <tr><td>13.0</td><td>2</td><td>3</td><td></td><td></td><td></td><td></td><td></td><td></td></tr> <tr><td>12.5</td><td></td><td></td><td></td><td></td><td></td><td></td><td></td><td></td></tr> <tr><td>12.0</td><td>3</td><td></td><td></td><td></td><td></td><td></td><td></td><td></td></tr> </tbody> </table>	Door overlay	Cup distance								3	4	5	6	7	8			22.0						-2			21.0					-2				20.0				-2		0			19.0			-2		0				18.0		-2		0	2				17.0	-2		0	2	3				16.5									16.0	0	2	3						15.5									15.0	0	2	3						14.5									14.0	2	3							13.5									13.0	2	3							12.5									12.0	3								<table border="1"> <thead> <tr> <th rowspan="2">Door overlay</th> <th colspan="8">Cup distance</th> </tr> <tr> <th>3</th> <th>4</th> <th>5</th> <th>6</th> <th>7</th> <th>8</th> <th></th> <th></th> </tr> </thead> <tbody> <tr><td>14.5</td><td></td><td></td><td></td><td></td><td>-2</td><td></td><td></td><td></td></tr> <tr><td>13.5</td><td></td><td></td><td></td><td>-2</td><td></td><td>0</td><td></td><td></td></tr> <tr><td>12.5</td><td></td><td></td><td>-2</td><td></td><td>0</td><td></td><td></td><td></td></tr> <tr><td>11.5</td><td></td><td>-2</td><td></td><td>0</td><td>2</td><td></td><td></td><td></td></tr> <tr><td>10.5</td><td>-2</td><td></td><td>0</td><td>2</td><td>3</td><td></td><td></td><td></td></tr> <tr><td>10.0</td><td></td><td></td><td></td><td></td><td></td><td></td><td></td><td></td></tr> <tr><td>9.5</td><td>0</td><td>2</td><td>3</td><td></td><td></td><td></td><td></td><td></td></tr> <tr><td>9.0</td><td></td><td></td><td></td><td></td><td></td><td></td><td></td><td></td></tr> <tr><td>8.5</td><td>0</td><td>2</td><td>3</td><td></td><td></td><td></td><td></td><td></td></tr> <tr><td>8.0</td><td></td><td></td><td></td><td></td><td></td><td></td><td></td><td></td></tr> <tr><td>7.5</td><td>2</td><td>3</td><td></td><td></td><td></td><td></td><td></td><td></td></tr> <tr><td>7.0</td><td></td><td></td><td></td><td></td><td></td><td></td><td></td><td></td></tr> <tr><td>6.5</td><td>2</td><td>3</td><td></td><td></td><td></td><td></td><td></td><td></td></tr> <tr><td>6.0</td><td></td><td></td><td></td><td></td><td></td><td></td><td></td><td></td></tr> <tr><td>5.5</td><td>3</td><td></td><td></td><td></td><td></td><td></td><td></td><td></td></tr> </tbody> </table>	Door overlay	Cup distance								3	4	5	6	7	8			14.5					-2				13.5				-2		0			12.5			-2		0				11.5		-2		0	2				10.5	-2		0	2	3				10.0									9.5	0	2	3						9.0									8.5	0	2	3						8.0									7.5	2	3							7.0									6.5	2	3							6.0									5.5	3								<table border="1"> <thead> <tr> <th rowspan="2">Door reveal</th> <th colspan="5">Cup distance</th> </tr> <tr> <th>3</th> <th>4</th> <th>5</th> <th></th> <th></th> </tr> </thead> <tbody> <tr><td>1.0</td><td>19</td><td>21</td><td></td><td></td><td></td></tr> <tr><td>1.5</td><td></td><td></td><td></td><td></td><td></td></tr> <tr><td>2.0</td><td></td><td>21</td><td></td><td></td><td></td></tr> <tr><td>3.0</td><td>21</td><td></td><td></td><td></td><td></td></tr> </tbody> </table>	Door reveal	Cup distance					3	4	5			1.0	19	21				1.5						2.0		21				3.0	21				
Door overlay		Cup distance																																																																																																																																																																																																																																																																																																																																																																																																																																																																																																																					
	3	4	5	6	7	8																																																																																																																																																																																																																																																																																																																																																																																																																																																																																																																	
25.0						-2																																																																																																																																																																																																																																																																																																																																																																																																																																																																																																																	
24.0					-2																																																																																																																																																																																																																																																																																																																																																																																																																																																																																																																		
23.0				-2		0																																																																																																																																																																																																																																																																																																																																																																																																																																																																																																																	
22.0			-2		0																																																																																																																																																																																																																																																																																																																																																																																																																																																																																																																		
21.0		-2		0	2																																																																																																																																																																																																																																																																																																																																																																																																																																																																																																																		
20.0	-2		0	2	3																																																																																																																																																																																																																																																																																																																																																																																																																																																																																																																		
19.0		0	2	3																																																																																																																																																																																																																																																																																																																																																																																																																																																																																																																			
18.5																																																																																																																																																																																																																																																																																																																																																																																																																																																																																																																							
18.0	0	2	3																																																																																																																																																																																																																																																																																																																																																																																																																																																																																																																				
17.5																																																																																																																																																																																																																																																																																																																																																																																																																																																																																																																							
17.0	2	3																																																																																																																																																																																																																																																																																																																																																																																																																																																																																																																					
16.5																																																																																																																																																																																																																																																																																																																																																																																																																																																																																																																							
16.0	2	3																																																																																																																																																																																																																																																																																																																																																																																																																																																																																																																					
15.5																																																																																																																																																																																																																																																																																																																																																																																																																																																																																																																							
15.0	3																																																																																																																																																																																																																																																																																																																																																																																																																																																																																																																						
Door overlay	Cup distance																																																																																																																																																																																																																																																																																																																																																																																																																																																																																																																						
	3	4	5	6	7	8																																																																																																																																																																																																																																																																																																																																																																																																																																																																																																																	
22.0						-2																																																																																																																																																																																																																																																																																																																																																																																																																																																																																																																	
21.0					-2																																																																																																																																																																																																																																																																																																																																																																																																																																																																																																																		
20.0				-2		0																																																																																																																																																																																																																																																																																																																																																																																																																																																																																																																	
19.0			-2		0																																																																																																																																																																																																																																																																																																																																																																																																																																																																																																																		
18.0		-2		0	2																																																																																																																																																																																																																																																																																																																																																																																																																																																																																																																		
17.0	-2		0	2	3																																																																																																																																																																																																																																																																																																																																																																																																																																																																																																																		
16.5																																																																																																																																																																																																																																																																																																																																																																																																																																																																																																																							
16.0	0	2	3																																																																																																																																																																																																																																																																																																																																																																																																																																																																																																																				
15.5																																																																																																																																																																																																																																																																																																																																																																																																																																																																																																																							
15.0	0	2	3																																																																																																																																																																																																																																																																																																																																																																																																																																																																																																																				
14.5																																																																																																																																																																																																																																																																																																																																																																																																																																																																																																																							
14.0	2	3																																																																																																																																																																																																																																																																																																																																																																																																																																																																																																																					
13.5																																																																																																																																																																																																																																																																																																																																																																																																																																																																																																																							
13.0	2	3																																																																																																																																																																																																																																																																																																																																																																																																																																																																																																																					
12.5																																																																																																																																																																																																																																																																																																																																																																																																																																																																																																																							
12.0	3																																																																																																																																																																																																																																																																																																																																																																																																																																																																																																																						
Door overlay	Cup distance																																																																																																																																																																																																																																																																																																																																																																																																																																																																																																																						
	3	4	5	6	7	8																																																																																																																																																																																																																																																																																																																																																																																																																																																																																																																	
14.5					-2																																																																																																																																																																																																																																																																																																																																																																																																																																																																																																																		
13.5				-2		0																																																																																																																																																																																																																																																																																																																																																																																																																																																																																																																	
12.5			-2		0																																																																																																																																																																																																																																																																																																																																																																																																																																																																																																																		
11.5		-2		0	2																																																																																																																																																																																																																																																																																																																																																																																																																																																																																																																		
10.5	-2		0	2	3																																																																																																																																																																																																																																																																																																																																																																																																																																																																																																																		
10.0																																																																																																																																																																																																																																																																																																																																																																																																																																																																																																																							
9.5	0	2	3																																																																																																																																																																																																																																																																																																																																																																																																																																																																																																																				
9.0																																																																																																																																																																																																																																																																																																																																																																																																																																																																																																																							
8.5	0	2	3																																																																																																																																																																																																																																																																																																																																																																																																																																																																																																																				
8.0																																																																																																																																																																																																																																																																																																																																																																																																																																																																																																																							
7.5	2	3																																																																																																																																																																																																																																																																																																																																																																																																																																																																																																																					
7.0																																																																																																																																																																																																																																																																																																																																																																																																																																																																																																																							
6.5	2	3																																																																																																																																																																																																																																																																																																																																																																																																																																																																																																																					
6.0																																																																																																																																																																																																																																																																																																																																																																																																																																																																																																																							
5.5	3																																																																																																																																																																																																																																																																																																																																																																																																																																																																																																																						
Door reveal	Cup distance																																																																																																																																																																																																																																																																																																																																																																																																																																																																																																																						
	3	4	5																																																																																																																																																																																																																																																																																																																																																																																																																																																																																																																				
1.0	19	21																																																																																																																																																																																																																																																																																																																																																																																																																																																																																																																					
1.5																																																																																																																																																																																																																																																																																																																																																																																																																																																																																																																							
2.0		21																																																																																																																																																																																																																																																																																																																																																																																																																																																																																																																					
3.0	21																																																																																																																																																																																																																																																																																																																																																																																																																																																																																																																						
Mounting plate height	Mounting plate height	Mounting plate height	Mounting plate height	Mounting plate height	Mounting plate height	Mounting plate height	Mounting plate height																																																																																																																																																																																																																																																																																																																																																																																																																																																																																																																

MINIMUM GAP

Door thickness	Cup distance							
	3	4	5	6	7	8		
32.0	1.0	1.0						
31.0	1.0	1.0	1.0					
30.0	1.0	1.0	1.0					
29.0	1.0	1.0	1.0	1.0	1.0	1.0		
28.0	1.0	1.0	1.0	1.0	1.0	1.0		
26.0	1.0	1.0	1.0	1.0	1.0	1.0		
25.0	1.0	1.0	1.0	1.0	1.0	1.0		
24.0	1.0	1.0	1.0	1.0	1.0	1.0		
22.0	1.0	1.0	1.0	1.0	1.0	1.0		
21.0	1.0	1.0	1.0	1.0	1.0	1.0		
20.0	1.0	1.0	1.0	1.0	1.0	1.0		
18.0	1.0	1.0	1.0	1.0	1.0	1.0		
16.0	1.0	1.0	1.0	1.0	1.0	1.0		

MINIMUM REVEAL

Door thickness	Cup distance							
	3	4	5	6	7	8		
32.0	0.2	0.2						
31.0	0.2	0.2	0.2	0.2				
30.0	0.2	0.2	0.2	0.2	0.2			
29.0	0.2	0.2	0.2	0.2	0.2	0.2		
28.0	0.0	0.0	0.0	0.0	0.0	0.0		
26.0	0.0	0.0	0.0	0.0	0.0	0.0		
25.0	0.0	0.0	0.0	0.0	0.0	0.0		
24.0	0.0	0.0	0.0	0.0	0.0	0.0		
22.0	0.0	0.0	0.0	0.0	0.0	0.0		
21.0	0.0	0.0	0.0	0.0	0.0	0.0		
20.0	0.0	0.0	0.0	0.0	0.0	0.0		
18.0	0.0	0.0	0.0	0.0	0.0	0.0		
16.0	0.0	0.0	0.0	0.0	0.0	0.0		

■ Only possible with 120° angle reduction clip

NOTES

The minimum gap is the clearance required between the cabinet face and the closed door so that the door can be opened without hindrance.

Minimum reveal for doors with chamfered edges (R = 1 mm) with factory setting.

Up to door thickness 28 mm, no reveals are necessary. For door thicknesses from 29 mm, we recommend a trial fitting.

DRILLING PATTERNS 45/9.5

For screw fitting	For press fitting	Impresso combination drilling pattern

CUP DIMENSIONS

() Impresso

TIOMOS 95

95° hinge (door thicknesses up to 28 mm)



- 95° opening angle
- Optimal reveals for door thicknesses up to 28 mm
- With convenient depth adjustment via worm screw
- 3-dimensional adjustment with corresponding mounting plate
- Surfaces: Nickel or Night (especially for dark cabinet materials and woods)

Available in three versions:

- With integrated damper (3 adjustable damping levels)
- Without integrated damper
- Without self-closing mechanism (without spring)

ORDER INFORMATION FOR DRILLING PATTERN 45/9.5, NICKEL

Door overlay	Cranking	Damper		Without spring	Art. No.		
		With	Without		Click-on for screw fitting	Click-on for press fitting	Impresso tool-free
Full overlay ¹	0	■	-	-	F028 138567	F028 138571	F017 139353
		-	■	-	F045 138505	F045 138509	F034 139324
		-	■	■	F046 138627	F046 138631	F035 139381
Overlay ¹	3	■	-	-	F028 138568	F028 138572	F017 139354
		-	■	-	F045 138506	F045 138510	F034 139325
		-	■	■	F046 138628	F046 138632	F035 139382
Half overlay ²	9.5	■	-	-	F028 138569	F028 138573	F017 139355
		-	■	-	F045 138507	F045 138511	F034 139326
		-	■	■	-	F046 138633	-
Inset ²	19	■	-	-	F028 138570	F028 138574	F017 139356
		-	■	-	F045 138508	F045 138512	F034 139327
		-	■	■	-	F046 138634	-

¹ Cup material: steel, nickel-plated/Arm material: steel, nickel-plated
² Cup material: steel, nickel-plated/Arm material: zamak, nickel-plated

ORDER INFORMATION FOR DRILLING PATTERN 45/9.5, NIGHT

Door overlay	Cranking	Damper		Without spring	Art. No.		
		With	Without		Click-on for screw fitting		
Overlay ¹	3	■	-	-	F028 139138		
		-	■	-	F045 149534		
		-	■	■	F046 149609		
Half overlay ²	9.5	■	-	-	F028 140936		
		-	■	-	F045 149535		
		-	■	■	F046 149610		
Inset ²	19	■	-	-	F028 140939		
		-	■	-	F045 149536		
		-	■	■	F046 149611		

¹ Cup material: steel, Night/Arm material: steel, Night
² Cup material: steel, Night/Arm material: zamak, Night

PAGE REFERENCES

Tiomos mounting plates	86	Tipmatic	114		
Accessories	96	Assembly technology	637		
Technical information	100	Assembly aids	654		

PLANNING DIMENSIONS

All dimensions in millimetres

Full overlay	K0	Overlay	K3	Half overlay	K9.5	Inset ¹	K19																																																																																																																																																																																																																																																																																																																																																														
Mounting plate height 2		Mounting plate height 2		Mounting plate height 2		Mounting plate height 2 ¹ Set mounting plate back by door thickness + 1.5 mm																																																																																																																																																																																																																																																																																																																																																															
<table border="1"> <thead> <tr> <th rowspan="2">0</th> <th colspan="5">Cup distance</th> </tr> <tr> <th>3</th> <th>4</th> <th>5</th> <th>6</th> <th>7</th> </tr> </thead> <tbody> <tr><td>24.0</td><td></td><td></td><td></td><td></td><td>-2</td></tr> <tr><td>23.0</td><td></td><td></td><td></td><td>-2</td><td></td></tr> <tr><td>22.0</td><td></td><td></td><td>-2</td><td></td><td>0</td></tr> <tr><td>21.0</td><td></td><td>-2</td><td></td><td>0</td><td></td></tr> <tr><td>20.0</td><td>-2</td><td></td><td>0</td><td></td><td>2</td></tr> <tr><td>19.0</td><td></td><td>0</td><td></td><td>2</td><td>3</td></tr> <tr><td>18.5</td><td></td><td></td><td></td><td></td><td></td></tr> <tr><td>18.0</td><td>0</td><td></td><td></td><td>2</td><td>3</td></tr> <tr><td>17.5</td><td></td><td></td><td></td><td></td><td></td></tr> <tr><td>17.0</td><td></td><td>2</td><td></td><td>3</td><td></td></tr> <tr><td>16.5</td><td></td><td></td><td></td><td></td><td></td></tr> <tr><td>16.0</td><td>2</td><td>3</td><td></td><td></td><td></td></tr> <tr><td>15.5</td><td></td><td></td><td></td><td></td><td></td></tr> <tr><td>15.0</td><td>3</td><td></td><td></td><td></td><td></td></tr> </tbody> </table>		0	Cup distance					3	4	5	6	7	24.0					-2	23.0				-2		22.0			-2		0	21.0		-2		0		20.0	-2		0		2	19.0		0		2	3	18.5						18.0	0			2	3	17.5						17.0		2		3		16.5						16.0	2	3				15.5						15.0	3					<table border="1"> <thead> <tr> <th rowspan="2">3</th> <th colspan="5">Cup distance</th> </tr> <tr> <th>3</th> <th>4</th> <th>5</th> <th>6</th> <th>7</th> </tr> </thead> <tbody> <tr><td>21.0</td><td></td><td></td><td></td><td></td><td>-2</td></tr> <tr><td>20.0</td><td></td><td></td><td></td><td>-2</td><td></td></tr> <tr><td>19.0</td><td></td><td></td><td>-2</td><td></td><td>0</td></tr> <tr><td>18.0</td><td></td><td>-2</td><td></td><td>0</td><td></td></tr> <tr><td>17.0</td><td>-2</td><td></td><td>0</td><td></td><td>2</td></tr> <tr><td>16.5</td><td></td><td></td><td></td><td></td><td></td></tr> <tr><td>16.0</td><td></td><td>0</td><td></td><td>2</td><td>3</td></tr> <tr><td>15.5</td><td></td><td></td><td></td><td></td><td></td></tr> <tr><td>15.0</td><td>0</td><td></td><td></td><td>2</td><td>3</td></tr> <tr><td>14.5</td><td></td><td></td><td></td><td></td><td></td></tr> <tr><td>14.0</td><td></td><td>2</td><td></td><td>3</td><td></td></tr> <tr><td>13.5</td><td></td><td></td><td></td><td></td><td></td></tr> <tr><td>13.0</td><td>2</td><td>3</td><td></td><td></td><td></td></tr> <tr><td>12.5</td><td></td><td></td><td></td><td></td><td></td></tr> <tr><td>12.0</td><td>3</td><td></td><td></td><td></td><td></td></tr> </tbody> </table>		3	Cup distance					3	4	5	6	7	21.0					-2	20.0				-2		19.0			-2		0	18.0		-2		0		17.0	-2		0		2	16.5						16.0		0		2	3	15.5						15.0	0			2	3	14.5						14.0		2		3		13.5						13.0	2	3				12.5						12.0	3					<table border="1"> <thead> <tr> <th rowspan="2">9.5</th> <th colspan="5">Cup distance</th> </tr> <tr> <th>3</th> <th>4</th> <th>5</th> <th>6</th> <th>7</th> </tr> </thead> <tbody> <tr><td>14.5</td><td></td><td></td><td></td><td></td><td>-2</td></tr> <tr><td>13.5</td><td></td><td></td><td></td><td>-2</td><td></td></tr> <tr><td>12.5</td><td></td><td></td><td>-2</td><td></td><td>0</td></tr> <tr><td>11.5</td><td></td><td>-2</td><td></td><td>0</td><td></td></tr> <tr><td>10.5</td><td>-2</td><td></td><td>0</td><td></td><td>2</td></tr> <tr><td>10.0</td><td></td><td></td><td></td><td></td><td></td></tr> <tr><td>9.5</td><td></td><td>0</td><td></td><td>2</td><td>3</td></tr> <tr><td>9.0</td><td></td><td></td><td></td><td></td><td></td></tr> <tr><td>8.5</td><td>0</td><td></td><td></td><td>2</td><td>3</td></tr> <tr><td>8.0</td><td></td><td></td><td></td><td></td><td></td></tr> <tr><td>7.5</td><td></td><td>2</td><td></td><td>3</td><td></td></tr> <tr><td>7.0</td><td></td><td></td><td></td><td></td><td></td></tr> <tr><td>6.5</td><td>2</td><td>3</td><td></td><td></td><td></td></tr> <tr><td>6.0</td><td></td><td></td><td></td><td></td><td></td></tr> <tr><td>5.5</td><td>3</td><td></td><td></td><td></td><td></td></tr> </tbody> </table>		9.5	Cup distance					3	4	5	6	7	14.5					-2	13.5				-2		12.5			-2		0	11.5		-2		0		10.5	-2		0		2	10.0						9.5		0		2	3	9.0						8.5	0			2	3	8.0						7.5		2		3		7.0						6.5	2	3				6.0						5.5	3					<table border="1"> <thead> <tr> <th rowspan="2">19</th> <th colspan="5">Cup distance</th> </tr> <tr> <th>3</th> <th>4</th> <th>5</th> <th>6</th> <th>7</th> </tr> </thead> <tbody> <tr><td>0.0</td><td></td><td>0</td><td></td><td>2</td><td>3</td></tr> <tr><td>0.5</td><td></td><td></td><td></td><td></td><td></td></tr> <tr><td>1.0</td><td>0</td><td></td><td></td><td>2</td><td>3</td></tr> <tr><td>1.5</td><td></td><td></td><td></td><td></td><td></td></tr> <tr><td>2.0</td><td></td><td>2</td><td></td><td>3</td><td></td></tr> <tr><td>3.0</td><td>2</td><td>3</td><td></td><td></td><td></td></tr> <tr><td>4.0</td><td>3</td><td></td><td></td><td></td><td></td></tr> </tbody> </table>		19	Cup distance					3	4	5	6	7	0.0		0		2	3	0.5						1.0	0			2	3	1.5						2.0		2		3		3.0	2	3				4.0	3				
0	Cup distance																																																																																																																																																																																																																																																																																																																																																																				
	3	4	5	6	7																																																																																																																																																																																																																																																																																																																																																																
24.0					-2																																																																																																																																																																																																																																																																																																																																																																
23.0				-2																																																																																																																																																																																																																																																																																																																																																																	
22.0			-2		0																																																																																																																																																																																																																																																																																																																																																																
21.0		-2		0																																																																																																																																																																																																																																																																																																																																																																	
20.0	-2		0		2																																																																																																																																																																																																																																																																																																																																																																
19.0		0		2	3																																																																																																																																																																																																																																																																																																																																																																
18.5																																																																																																																																																																																																																																																																																																																																																																					
18.0	0			2	3																																																																																																																																																																																																																																																																																																																																																																
17.5																																																																																																																																																																																																																																																																																																																																																																					
17.0		2		3																																																																																																																																																																																																																																																																																																																																																																	
16.5																																																																																																																																																																																																																																																																																																																																																																					
16.0	2	3																																																																																																																																																																																																																																																																																																																																																																			
15.5																																																																																																																																																																																																																																																																																																																																																																					
15.0	3																																																																																																																																																																																																																																																																																																																																																																				
3	Cup distance																																																																																																																																																																																																																																																																																																																																																																				
	3	4	5	6	7																																																																																																																																																																																																																																																																																																																																																																
21.0					-2																																																																																																																																																																																																																																																																																																																																																																
20.0				-2																																																																																																																																																																																																																																																																																																																																																																	
19.0			-2		0																																																																																																																																																																																																																																																																																																																																																																
18.0		-2		0																																																																																																																																																																																																																																																																																																																																																																	
17.0	-2		0		2																																																																																																																																																																																																																																																																																																																																																																
16.5																																																																																																																																																																																																																																																																																																																																																																					
16.0		0		2	3																																																																																																																																																																																																																																																																																																																																																																
15.5																																																																																																																																																																																																																																																																																																																																																																					
15.0	0			2	3																																																																																																																																																																																																																																																																																																																																																																
14.5																																																																																																																																																																																																																																																																																																																																																																					
14.0		2		3																																																																																																																																																																																																																																																																																																																																																																	
13.5																																																																																																																																																																																																																																																																																																																																																																					
13.0	2	3																																																																																																																																																																																																																																																																																																																																																																			
12.5																																																																																																																																																																																																																																																																																																																																																																					
12.0	3																																																																																																																																																																																																																																																																																																																																																																				
9.5	Cup distance																																																																																																																																																																																																																																																																																																																																																																				
	3	4	5	6	7																																																																																																																																																																																																																																																																																																																																																																
14.5					-2																																																																																																																																																																																																																																																																																																																																																																
13.5				-2																																																																																																																																																																																																																																																																																																																																																																	
12.5			-2		0																																																																																																																																																																																																																																																																																																																																																																
11.5		-2		0																																																																																																																																																																																																																																																																																																																																																																	
10.5	-2		0		2																																																																																																																																																																																																																																																																																																																																																																
10.0																																																																																																																																																																																																																																																																																																																																																																					
9.5		0		2	3																																																																																																																																																																																																																																																																																																																																																																
9.0																																																																																																																																																																																																																																																																																																																																																																					
8.5	0			2	3																																																																																																																																																																																																																																																																																																																																																																
8.0																																																																																																																																																																																																																																																																																																																																																																					
7.5		2		3																																																																																																																																																																																																																																																																																																																																																																	
7.0																																																																																																																																																																																																																																																																																																																																																																					
6.5	2	3																																																																																																																																																																																																																																																																																																																																																																			
6.0																																																																																																																																																																																																																																																																																																																																																																					
5.5	3																																																																																																																																																																																																																																																																																																																																																																				
19	Cup distance																																																																																																																																																																																																																																																																																																																																																																				
	3	4	5	6	7																																																																																																																																																																																																																																																																																																																																																																
0.0		0		2	3																																																																																																																																																																																																																																																																																																																																																																
0.5																																																																																																																																																																																																																																																																																																																																																																					
1.0	0			2	3																																																																																																																																																																																																																																																																																																																																																																
1.5																																																																																																																																																																																																																																																																																																																																																																					
2.0		2		3																																																																																																																																																																																																																																																																																																																																																																	
3.0	2	3																																																																																																																																																																																																																																																																																																																																																																			
4.0	3																																																																																																																																																																																																																																																																																																																																																																				
Door overlay		Door overlay		Door overlay		Door reveal																																																																																																																																																																																																																																																																																																																																																															
Mounting plate height		Mounting plate height		Mounting plate height		Mounting plate height																																																																																																																																																																																																																																																																																																																																																															

MINIMUM GAP

Door thickness	Cup distance				
	3	4	5	6	7
36.0	1.0	1.0	1.0	1.4	2.4
30.0	1.0	1.0	1.0	1.0	1.9
28.0	1.0	1.0	1.0	1.0	1.7
26.0	1.0	1.0	1.0	1.0	1.5
24.0	1.0	1.0	1.0	1.0	1.4
22.0	1.0	1.0	1.0	1.0	1.2
20.0	1.0	1.0	1.0	1.0	1.0
18.0	1.0	1.0	1.0	1.0	1.0
16.0	1.0	1.0	1.0	1.0	1.0

Minimum gap

MINIMUM REVEAL

Door thickness	Cup distance				
	3	4	5	6	7
36.0	10.6	9.6	8.6	7.6	6.7
30.0	4.5	3.5	2.5	2.5	1.5
28.0	2.0	1.5	1.5	1.3	1.3
26.0	1.0	1.0	1.0	1.0	1.0
24.0	0.6	0.6	0.6	0.6	0.6
22.0	0.5	0.5	0.5	0.5	0.5
20.0	0.3	0.3	0.3	0.3	0.3
18.0	0.2	0.2	0.2	0.2	0.2
16.0	0.2	0.2	0.2	0.2	0.2

Minimum reveal (F)

NOTES

The minimum gap is the clearance required between the cabinet face and the closed door so that the door can be opened without hindrance.

Minimum reveal for doors with chamfered edges (R = 1 mm) with factory setting.

DRILLING PATTERNS 45/9.5

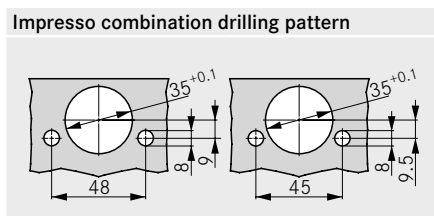
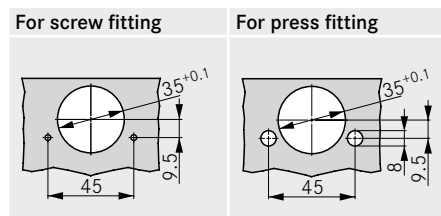

CUP DIMENSIONS

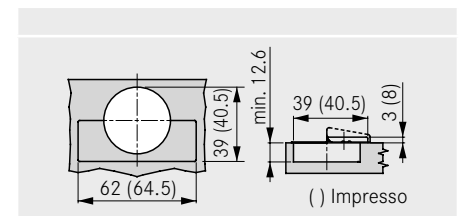

TIOMOS 110 AL

110° aluminium frame hinge (frame thicknesses up to 24 mm)

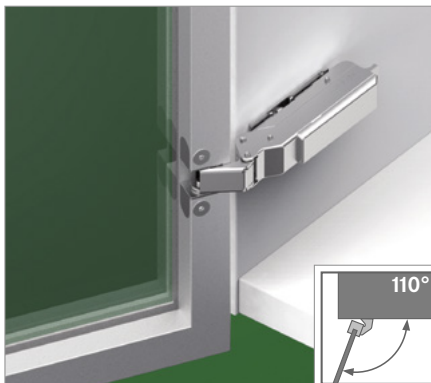

- 110° opening angle
- Optimal reveal for aluminium frames up to a max. frame thickness of 24 mm and frame width of 22 mm
- Hinge not visible from the outside
- With convenient depth adjustment via worm screw
- 3-dimensional adjustment with corresponding mounting plate
- Surfaces: Nickel or Night (especially for dark cabinet materials and woods)

Available in three versions:

- With integrated damper (3 adjustable damping levels)
- Without integrated damper
- Without self-closing mechanism (without spring)

ORDER INFORMATION, NICKEL

Door overlay	Cranking	Damper		Without spring	Click-on for screw fitting	Art. No.	
		With	Without				
Full overlay ¹	0	■	-	-	F028 138 154		
		-	■	-	F045 138 061		
		-	■	■	F046 138 245		
Overlay ¹	3	■	-	-	F028 138 155		
		-	■	-	F045 138 062		
		-	■	■	F046 138 246		
Half overlay ²	9.5	■	-	-	F028 138 156		
		-	■	-	F045 138 063		
		-	■	■	F046 138 247		
Inset ²	19	■	-	-	F028 138 157		
		-	■	-	F045 138 064		
		-	■	■	F046 138 248		

¹ Cup material: zamak, nickel-plated/Arm material: steel, nickel-plated

² Cup material: zamak, nickel-plated/Arm material: zamak, nickel-plated

ORDER INFORMATION, NIGHT

Door overlay	Cranking	Damper		Without spring	Click-on for screw fitting	Art. No.	
		With	Without				
Overlay ¹	3	■	-	-	F028 140 404		
		-	■	-	F045 149 510		
		-	■	■	F046 149 594		

¹ Cup material: zamak, Night/Arm material: steel, Night

² Cup material: zamak, Night/Arm material: zamak, Night

PAGE REFERENCES

Tiomos mounting plates	86	Tipmatic	114		
Accessories	96	Assembly technology	637		
Technical information	100	Assembly aids	654		

PLANNING DIMENSIONS

All dimensions in millimetres

Full overlay	K0	Overlay	K3	Half overlay	K9.5	Inset ¹	K19																																																																																
<p>Mounting plate height 2</p>		<p>Mounting plate height 2</p>		<p>Mounting plate height 2</p>		<p>Mounting plate height 2 ¹ Set mounting plate back by door thickness + 1.5 mm</p>																																																																																	
<table border="1"> <thead> <tr> <th>Door overlay</th> <th>Cup distance</th> <th colspan="3"></th> </tr> </thead> <tbody> <tr> <td>19.0</td> <td>0</td> <td></td> <td></td> <td></td> </tr> <tr> <td>17.0</td> <td>2</td> <td></td> <td></td> <td></td> </tr> <tr> <td>16.0</td> <td>3</td> <td></td> <td></td> <td></td> </tr> </tbody> </table> <p>Mounting plate height</p>		Door overlay	Cup distance				19.0	0				17.0	2				16.0	3				<table border="1"> <thead> <tr> <th>Door overlay</th> <th>Cup distance</th> <th colspan="3"></th> </tr> </thead> <tbody> <tr> <td>16.0</td> <td>0</td> <td></td> <td></td> <td></td> </tr> <tr> <td>14.0</td> <td>2</td> <td></td> <td></td> <td></td> </tr> <tr> <td>13.0</td> <td>3</td> <td></td> <td></td> <td></td> </tr> </tbody> </table> <p>Mounting plate height</p>		Door overlay	Cup distance				16.0	0				14.0	2				13.0	3				<table border="1"> <thead> <tr> <th>Door overlay</th> <th>Cup distance</th> <th colspan="3"></th> </tr> </thead> <tbody> <tr> <td>9.5</td> <td>0</td> <td></td> <td></td> <td></td> </tr> <tr> <td>7.5</td> <td>2</td> <td></td> <td></td> <td></td> </tr> <tr> <td>6.5</td> <td>3</td> <td></td> <td></td> <td></td> </tr> </tbody> </table> <p>Mounting plate height</p>		Door overlay	Cup distance				9.5	0				7.5	2				6.5	3				<table border="1"> <thead> <tr> <th>Door reveal</th> <th>Cup distance</th> <th colspan="3"></th> </tr> </thead> <tbody> <tr> <td>0.0</td> <td>0</td> <td></td> <td></td> <td></td> </tr> <tr> <td>2.0</td> <td>2</td> <td></td> <td></td> <td></td> </tr> <tr> <td>3.0</td> <td>3</td> <td></td> <td></td> <td></td> </tr> </tbody> </table> <p>Mounting plate height</p>		Door reveal	Cup distance				0.0	0				2.0	2				3.0	3			
Door overlay	Cup distance																																																																																						
19.0	0																																																																																						
17.0	2																																																																																						
16.0	3																																																																																						
Door overlay	Cup distance																																																																																						
16.0	0																																																																																						
14.0	2																																																																																						
13.0	3																																																																																						
Door overlay	Cup distance																																																																																						
9.5	0																																																																																						
7.5	2																																																																																						
6.5	3																																																																																						
Door reveal	Cup distance																																																																																						
0.0	0																																																																																						
2.0	2																																																																																						
3.0	3																																																																																						

MINIMUM REVEAL

Frame thickness	Frame width				
	18	19	20	21	22
24.0	2.4	2.1	2.1	2.1	2.0
22.0	1.6	1.6	1.6	1.5	1.5
21.0	1.4	1.3	1.3	1.3	1.3
20.0	1.1	1.1	1.1	1.1	1.1
19.0	0.9	0.9	0.9	0.9	0.9
18.0	0.7	0.7	0.7	0.7	0.7
17.0	0.6	0.6	0.6	0.6	0.6
16.0	0.6	0.6	0.6	0.6	0.6
Minimum reveal (F)					

INSTALLATION DIMENSIONS

Hinge dimensions and reveal calculation with factory setting

Fixing screws are not included

1

2

3

4

5

6

7

8

TIOMOS 110/90A

110° blind corner hinge (overlay)



- Hinge for overlay blind corner constructions
- 110° opening angle
- With convenient depth adjustment via worm screw
- 3-dimensional adjustment with corresponding mounting plate
- Minimum reveals
- Surfaces: Nickel or Night (especially for dark cabinet materials and woods)

Available in two versions:

- With integrated damper (3 adjustable damping levels)
- Without integrated damper

ORDER INFORMATION FOR DRILLING PATTERN 45/9.5, NICKEL

Door overlay		Damper		Without spring	Art. No.		
		With	Without		Click-on for screw fitting	Click-on for press fitting	Impresso tool-free
Overlay ¹		■	-	-	F028138535	F028138545	F017139341
		-	■	-	-	F045138483	-

¹ Cup material: steel, nickel-plated/Arm material: zamak, nickel-plated

ORDER INFORMATION FOR DRILLING PATTERN 45/9.5, NIGHT

Door overlay		Damper		Without spring	Art. No.		
		With	Without		Click-on for screw fitting		
Overlay ¹		■	-	-	F028140419		

¹ Cup material: steel, Night/Arm material: zamak, Night

PAGE REFERENCES

Tiomos mounting plates	86	Tipmatic	114		
Accessories	96	Assembly technology	637		
Technical information	100	Assembly aids	654		

PLANNING DIMENSIONS

All dimensions in millimetres

Inset

Cross mounting plates with mounting distance 37

Drilling distance (X)	Cup distance				
	3	4	5	6	7
30.0	18	19	20	21	22
29.0	17	18	19	20	21
28.0	16	17	18	19	20
27.0	15	16	17	18	19
26.0	14	15	16	17	18

Mounting plate height 0

Door overlay

Linear mounting plates

Drilling distance (X)	Cup distance				
	3	4	5	6	7
13.0	18	19	20	21	22
12.0	17	18	19	20	21
11.0	16	17	18	19	20
10.0	15	16	17	18	19
9.0	14	15	16	17	18

Door overlay

MINIMUM GAP

Door thickness	Cup distance					Minimum gap
	3	4	5	6	7	
24.0	1.0	1.0	1.0	1.2	2.1	
22.0	1.0	1.0	1.0	1.0	1.5	
21.0	1.0	1.0	1.0	1.0	1.2	
20.0	1.0	1.0	1.0	1.0	1.0	
19.0	1.0	1.0	1.0	1.0	1.0	
18.0	1.0	1.0	1.0	1.0	1.0	
17.0	1.0	1.0	1.0	1.0	1.0	
16.0	1.0	1.0	1.0	1.0	1.0	

NOTES

The minimum gap is the clearance required between the cabinet face and the closed door so that the door can be opened without hindrance.

DRILLING PATTERNS 45/9.5

For screw fitting

For press fitting

Impresso combination drilling pattern

CUP DIMENSIONS

() Impresso



TIOMOS 110/90E

110° blind corner hinge (inset)



- Hinge for blind corner constructions
- 110° opening angle
- With convenient depth adjustment via worm screw
- 3-dimensional adjustment with corresponding mounting plate
- Minimum reveals
- Surfaces: Nickel or Night (especially for dark cabinet materials and woods)

Available in three versions:

- With integrated damper (3 adjustable damping levels)
- Without integrated damper
- Without self-closing mechanism (without spring)

ORDER INFORMATION FOR DRILLING PATTERN 45/9.5, NICKEL

Door overlay		Damper		Without spring	Art. No.		
		With	Without		Click-on for screw fitting	Click-on for press fitting	Impresso tool-free
Inset ¹		■	-	-	F028138536	F028138546	F017139342
		-	■	-	F045138474	F045138484	F034139313
		-	■	■	F046138596	F046138606	F035139370

¹ Cup material: steel, nickel-plated/Arm material: zamak, nickel-plated

ORDER INFORMATION FOR DRILLING PATTERN 45/9.5, NIGHT

Door overlay		Damper		Without spring	Art. No.		
		With	Without		Click-on for screw fitting		
Inset ¹		■	-	-	F028140961		

¹ Cup material: steel, Night/Arm material: zamak, Night

PAGE REFERENCES

Tiomos mounting plates	86	Tipmatic	114		
Accessories	96	Assembly technology	637		
Technical information	100	Assembly aids	654		

PLANNING DIMENSIONS

All dimensions in millimetres

Inset

Cross mounting plates with mounting distance 37

Linear mounting plates

Drilling distance (X)	Cup distance				
	4	5	6	7	
28.0	1	0			
27.0	2	1	0		
26.0	3	2	1	0	
	Door reveal				

Mounting plate height 3

Drilling distance (X)	Cup distance				
	4	5	6	7	
11.0	1	0			
10.0	2	1	0		
9.0	3	2	1	0	
	Door reveal				

MINIMUM REVEAL

Door thickness	Cup distance					Minimum reveal (F)
	3	4	5	6	7	
24.0	2.4	2.1	2.1	2.1	2.0	
22.0	1.6	1.6	1.6	1.5	1.5	
21.0	1.4	1.3	1.3	1.3	1.3	
20.0	1.1	1.1	1.1	1.1	1.1	
19.0	0.9	0.9	0.9	0.9	0.9	
18.0	0.7	0.7	0.7	0.7	0.7	
17.0	0.6	0.6	0.6	0.6	0.6	
16.0	0.6	0.6	0.6	0.6	0.6	
	Minimum reveal (F)					

NOTES

Minimum reveal for doors with chamfered edges (R = 1 mm) with factory setting.

Use standard mounting plate height 3 to ensure that the door and blind corner surface are flush.

DRILLING PATTERNS 45/9.5

For screw fitting

For press fitting

Impresso combination drilling pattern

CUP DIMENSIONS

() Impresso



TIOMOS 110/30A

+30° angle corner cabinet hinge (overlay)

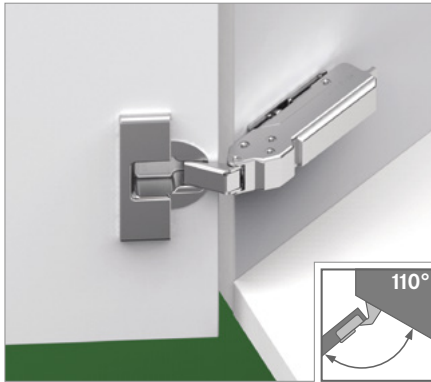

- For 30° angled cabinets
- 110° opening angle
- With convenient depth adjustment via worm screw
- 3-dimensional adjustment with corresponding mounting plate
- Minimum reveals

Available in three versions:

- With integrated damper (3 adjustable damping levels)
- Without integrated damper
- Without self-closing mechanism (without spring)

ORDER INFORMATION FOR DRILLING PATTERN 45/9.5, NICKEL

Door overlay		Damper			Without spring	Art. No.	
		With	Without	Click-on for screw fitting		Click-on for press fitting	
Overlay ¹		■	-	-	F028 138529	-	
		-	■	-	F045 138467	-	
		-	■	■	F046 138589	F046 138599	

¹ Cup material: steel, nickel-plated/Arm material: zamak, nickel-plated

PAGE REFERENCES

Tiomos mounting plates	86	Tipmatic	114		
Accessories	96	Assembly technology	637		
Technical information	100	Assembly aids	654		

PLANNING DIMENSIONS

All dimensions in millimetres

Overlay

Mounting plate height 0 Mounting plate height 6 Mounting plate height 9

Door overlay	Cup distance					
	3	4	5	6	7	
20.5					0	
19.5				0		
18.5			0		2	
17.5		0		2	3	
16.5	0					
16.0			2	3		
15.5						
15.0		2	3			
14.5						
14.0	2	3				
13.5						
13.0	3					
12.5				6		
11.5			6			
10.5		6				
	Mounting plate height					

Cross mounting plates with mounting distance 37 Linear mounting plates

X	Mounting plate height				
	0	2	3	6	
X	34.0	33.0	32.0	30.5	
	Cross mounting plate position (X)				

X	Mounting plate height		
	0	2	3
X	17.0	16.0	15.0
	Linear mounting plate position (X)		

MINIMUM GAP

Door thickness	Cup distance					
	3	4	5	6	7	
24.0	1.0	1.0	1.0	1.2	2.1	
22.0	1.0	1.0	1.0	1.0	1.5	
21.0	1.0	1.0	1.0	1.0	1.2	
20.0	1.0	1.0	1.0	1.0	1.0	
19.0	1.0	1.0	1.0	1.0	1.0	
18.0	1.0	1.0	1.0	1.0	1.0	
17.0	1.0	1.0	1.0	1.0	1.0	
16.0	1.0	1.0	1.0	1.0	1.0	
	Minimum gap					

MINIMUM REVEAL

Door thickness	Cup distance					
	3	4	5	6	7	
24.0	2.4	2.1	2.1	2.1	2.0	
22.0	1.6	1.6	1.6	1.5	1.5	
21.0	1.4	1.3	1.3	1.3	1.3	
20.0	1.1	1.1	1.1	1.1	1.1	
19.0	0.9	0.9	0.9	0.9	0.9	
18.0	0.7	0.7	0.7	0.7	0.7	
17.0	0.6	0.6	0.6	0.6	0.6	
16.0	0.6	0.6	0.6	0.6	0.6	
	Minimum reveal (F)					

NOTES

The minimum gap is the clearance required between the cabinet face and the closed door so that the door can be opened without hindrance.

Minimum reveal for doors with chamfered edges (R = 1 mm) with factory setting.

Hinge dimensions and reveal calculation with factory setting.

A trial fitting is recommended for door thicknesses from 24 mm.

DRILLING PATTERNS 45/9.5

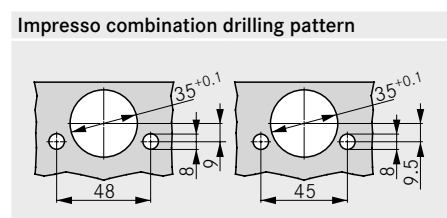
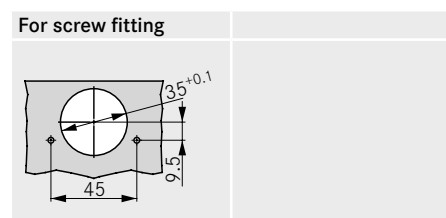

CUP DIMENSIONS

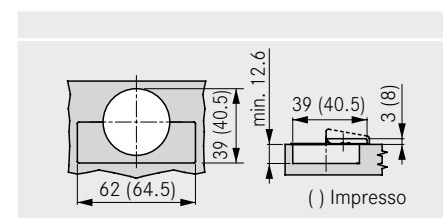

TIOMOS 110/30E

+30° corner cabinet hinge (inset)

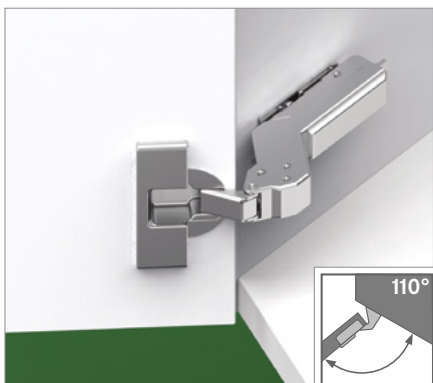

- For 30° angled cabinets
- 110° opening angle
- With convenient depth adjustment via worm screw
- 3-dimensional adjustment with corresponding mounting plate
- Minimum reveals

Available in three versions:

- With integrated damper (3 adjustable damping levels)
- Without integrated damper
- Without self-closing mechanism (without spring)

ORDER INFORMATION FOR DRILLING PATTERN 45/9.5, NICKEL

Door overlay		Damper		Without spring	Art. No.	
		With	Without		Click-on for screw fitting	Click-on for press fitting
Inset ¹		■	-	-	F028 138530	F028 138540
		-	■	-	F045 138468	F045 138478
		-	■	■	F046 138590	F046 138600

¹ Cup material: steel, nickel-plated/Arm material: zamak, nickel-plated

PAGE REFERENCES

Tiomos mounting plates	86	Tipmatic	114		
Accessories	96	Assembly technology	637		
Technical information	100	Assembly aids	654		

PLANNING DIMENSIONS

All dimensions in millimetres

Inset

Mounting plate height 9

Cross mounting plates with mounting distance 37

	Cup distance				
	3	4	5	6	7
22	9.5			12	
21	9				
20					12
19	8	9	9.5		
18		8	9		
17				9.5	
16			8		9.5
15	6				9

Door overlay

Mounting plate height

	Cup distance				
	3	4	5	6	7
22	63.5			61.5	
21	62.5				
20		61.5			60.0
19		61.0	60.0		
18		59.0	59.0		
17				58.0	
16			57.5		56.5
15	57.5				55.5

Door overlay

Cross mounting plate position (X)

MINIMUM REVEAL

	Cup distance				
	3	4	5	6	7
24.0	2.4	2.1	2.1	2.1	2.0
22.0	1.6	1.6	1.6	1.5	1.5
21.0	1.4	1.3	1.3	1.3	1.3
20.0	1.1	1.1	1.1	1.1	1.1
19.0	0.9	0.9	0.9	0.9	0.9
18.0	0.7	0.7	0.7	0.7	0.7
17.0	0.6	0.6	0.6	0.6	0.6
16.0	0.6	0.6	0.6	0.6	0.6
15.0	0.6	0.6	0.6	0.6	0.6

Door thickness

Minimum reveal (F)

NOTES

Minimum reveal for doors with chamfered edges (R = 1 mm) with factory setting.

A trial fitting is recommended for door thicknesses from 24 mm.

DRILLING PATTERNS 45/9.5

For screw fitting

Impresso combination drilling pattern

CUP DIMENSIONS

() Impresso



TIOMOS 110/37A

+37° angle corner cabinet hinge (overlay)

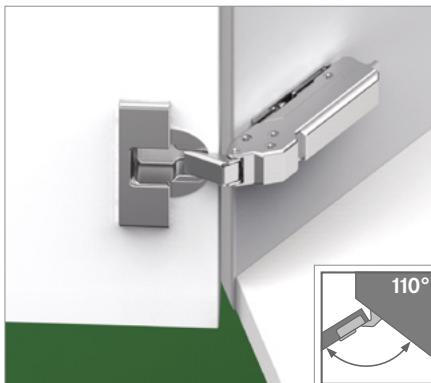

- For 37° angled cabinets
- 110° opening angle
- With convenient depth adjustment via worm screw
- 3-dimensional adjustment with corresponding mounting plate
- Minimum reveals

Available in three versions:

- With integrated damper (3 adjustable damping levels)
- Without integrated damper
- Without self-closing mechanism (without spring)

ORDER INFORMATION FOR DRILLING PATTERN 45/9.5, NICKEL

Door overlay		Damper		Without spring	Art. No.		
		With	Without		Click-on for screw fitting	Click-on for press fitting	Impresso tool-free
Overlay ¹		■	-	-	F028 138531	F028 138541	-
		-	■	-	F045 138469	F045 138479	F034 139308
		-	■	■	F046 138591	F046 138601	F035 139365

¹ Cup material: steel, nickel-plated/Arm material: zamak, nickel-plated

PAGE REFERENCES

Tiomos mounting plates	86	Tipmatic	114		
Accessories	96	Assembly technology	637		
Technical information	100	Assembly aids	654		

PLANNING DIMENSIONS

All dimensions in millimetres

Overlay

Mounting plate height 0 Mounting plate height 12 Mounting plate height 12

Door overlay	Cup distance					
	3	4	5	6	7	
21.5					0	
21.0				0		
20.0			0			
19.0		0				
18.5				2		
18.0	0				3	
17.5			2			
17.0				3		
16.5		2				
16.0			3			
15.5	2					
15.0		3				
14.5					6	
14.0	3					
13.0				6		
12.0			6			
11.0		6				
10.0	6					

Mounting plate height

Cross mounting plates with mounting distance 37 Linear mounting plates

X	Mounting plate height				
	0	2	3	6	
X	33.5	32.0	31.0	29.0	

Mounting plate position (X)

X	Mounting plate height		
	0	2	3
X	16.5	15.0	14.0

Linear mounting plate position (X)

MINIMUM GAP

Door thickness	Cup distance					
	3	4	5	6	7	
24.0	1.0	1.0	1.0	1.2	2.1	
22.0	1.0	1.0	1.0	1.0	1.5	
21.0	1.0	1.0	1.0	1.0	1.2	
20.0	1.0	1.0	1.0	1.0	1.0	
19.0	1.0	1.0	1.0	1.0	1.0	
18.0	1.0	1.0	1.0	1.0	1.0	
17.0	1.0	1.0	1.0	1.0	1.0	
16.0	1.0	1.0	1.0	1.0	1.0	

Minimum gap

MINIMUM REVEAL

Door thickness	Cup distance					
	3	4	5	6	7	
24.0	2.4	2.1	2.1	2.1	2.0	
22.0	1.6	1.6	1.6	1.5	1.5	
21.0	1.4	1.3	1.3	1.3	1.3	
20.0	1.1	1.1	1.1	1.1	1.1	
19.0	0.9	0.9	0.9	0.9	0.9	
18.0	0.7	0.7	0.7	0.7	0.7	
17.0	0.6	0.6	0.6	0.6	0.6	
16.0	0.6	0.6	0.6	0.6	0.6	

Minimum reveal (F)

NOTES

The minimum gap is the clearance required between the cabinet face and the closed door so that the door can be opened without hindrance.

Minimum reveal for doors with chamfered edges (R = 1 mm) with factory setting.

A trial fitting is recommended for door thicknesses from 24 mm.

DRILLING PATTERNS 45/9.5

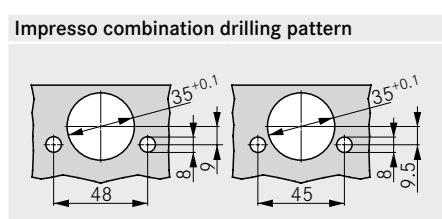
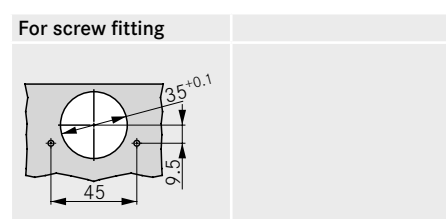

CUP DIMENSIONS

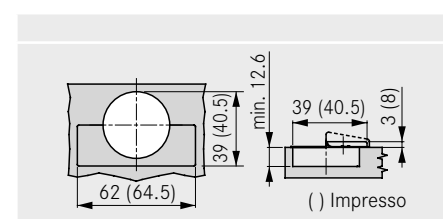

TIOMOS 110/37E

+37° corner cabinet hinge (inset)

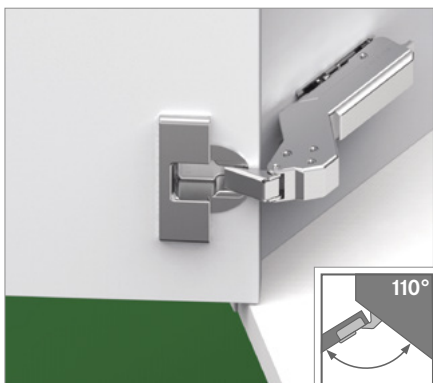

- For 37° angled cabinets
- 110° opening angle
- With convenient depth adjustment via worm screw
- 3-dimensional adjustment with corresponding mounting plate
- Minimum reveals

Available in three versions:

- With integrated damper (3 adjustable damping levels)
- Without integrated damper
- Without self-closing mechanism (without spring)

ORDER INFORMATION FOR DRILLING PATTERN 45/9.5, NICKEL

Door overlay		Damper		Without spring	Art. No.		
		With	Without		Click-on for screw fitting	Click-on for press fitting	Impresso tool-free
Inset ¹		■	-	-	F028 138532	F028 138542	-
		-	■	-	-	F045 138480	F034 139309
		-	■	■	F046 138592	F046 138602	F035 139366

¹ Cup material: steel, nickel-plated/Arm material: zamak, nickel-plated

PAGE REFERENCES

Tiomos mounting plates	86	Tipmatic	114		
Accessories	96	Assembly technology	637		
Technical information	100	Assembly aids	654		

PLANNING DIMENSIONS

All dimensions in millimetres

Inset

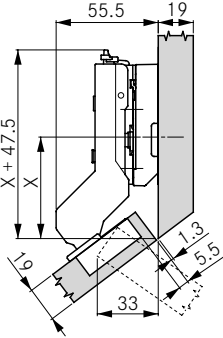

Mounting plate height 12

		Cup distance				
		3	4	5	6	7
22		12		14		15
21			12		14	
20				12		14
19					12	
18	9					
17		9.5				12
16	8	9	9.5			
15		8	9			
Door overlay						
		Mounting plate height				

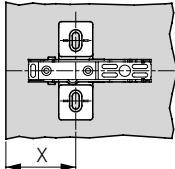

Cross mounting plates with mounting distance 37

		Cup distance				
		3	4	5	6	7
22		59.0		57.5		56.5
21			57.5		56.5	
20				56.5		55.0
19					55.0	
18	56.0					
17		54.5				53.0
16	54.5	54.0	53.0			
15		53.0	52.5			
Door overlay						
		Cross mounting plate position (X)				

MINIMUM REVEAL

		Cup distance				
		3	4	5	6	7
24.0		2.4	2.1	2.1	2.1	2.0
22.0		1.6	1.6	1.6	1.5	1.5
21.0		1.4	1.3	1.3	1.3	1.3
20.0		1.1	1.1	1.1	1.1	1.1
19.0		0.9	0.9	0.9	0.9	0.9
18.0		0.7	0.7	0.7	0.7	0.7
17.0		0.6	0.6	0.6	0.6	0.6
16.0		0.6	0.6	0.6	0.6	0.6
15.0		0.6	0.6	0.6	0.6	0.6
Door thickness						
		Minimum reveal (F)				

NOTES

Minimum reveal for doors with chamfered edges (R = 1 mm) with factory setting.
A trial fitting is recommended for door thicknesses from 24 mm.

DRILLING PATTERNS 45/9.5

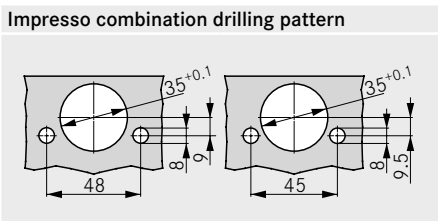
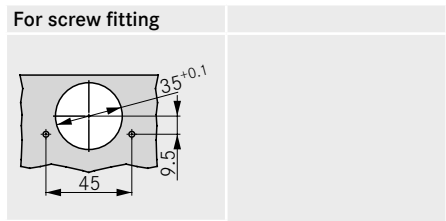

CUP DIMENSIONS

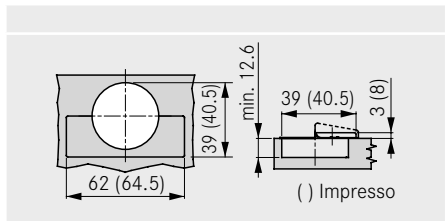

TIOMOS 110/45A

+45° angle corner cabinet hinge (overlay)



- For 45° angled cabinets
- 110° opening angle
- With convenient depth adjustment via worm screw
- 3-dimensional adjustment with corresponding mounting plate
- Minimum reveals
- Surfaces: Nickel or Night (especially for dark cabinet materials and woods)

Available in three versions:

- With integrated damper (3 adjustable damping levels)
- Without integrated damper
- Without self-closing mechanism (without spring)

ORDER INFORMATION FOR DRILLING PATTERN 45/9.5, NICKEL

Door overlay		Damper		Without spring	Art. No.		
		With	Without		Click-on for screw fitting	Click-on for press fitting	Impresso tool-free
Overlay ¹		■	-	-	F028 138533	F028 138543	F017 139339
		-	■	-	F045 138471	-	F034 139310
		-	■	■	F046 138593	-	F035 139367

¹ Cup material: steel, nickel-plated/Arm material: zamak, nickel-plated

ORDER INFORMATION FOR DRILLING PATTERN 45/9.5, NIGHT

Door overlay		Damper		Without spring	Art. No.		
		With	Without		Click-on for screw fitting		
Overlay ¹		■	-	-	F028 140962		

¹ Cup material: steel, Night/Arm material: zamak, Night

PAGE REFERENCES

Tiomas mounting plates	86	Tipmatic	114		
Accessories	96	Assembly technology	637		
Technical information	100	Assembly aids	654		

PLANNING DIMENSIONS

All dimensions in millimetres

Overlay

Mounting plate height 0

Mounting plate height 8

Mounting plate height 12

Door overlay	Cup distance					
	3	4	5	6	7	
19.5					0	
19.0						
18.5				0		
18.0						
17.5			0			
17.0						
16.5		0			2	
16.0						
15.5	0			2		3
15.0						
14.5			2			
14.0				3		
13.5		2				
13.0			3			
12.5	2					
12.0		3				
11.0	3				6	
10.0				6		

Mounting plate height

Cross mounting plates with mounting distance 37

Linear mounting plates

X	Mounting plate height				
	0	2	3	6	
X	30.5	28.5	27.5	24.5	

Cross mounting plate position (X)

X	Mounting plate height			
	0	2	3	
X	13.5	11.5	10.5	

Linear mounting plate position (X)

MINIMUM GAP

Door thickness	Cup distance					
	3	4	5	6	7	
24.0	1.0	1.0	1.0	1.2	2.1	
22.0	1.0	1.0	1.0	1.0	1.5	
21.0	1.0	1.0	1.0	1.0	1.2	
20.0	1.0	1.0	1.0	1.0	1.0	
19.0	1.0	1.0	1.0	1.0	1.0	
18.0	1.0	1.0	1.0	1.0	1.0	
17.0	1.0	1.0	1.0	1.0	1.0	
16.0	1.0	1.0	1.0	1.0	1.0	

Minimum gap

MINIMUM REVEAL

Door thickness	Cup distance					
	3	4	5	6	7	
24.0	2.4	2.1	2.1	2.1	2.0	
22.0	1.6	1.6	1.6	1.5	1.5	
21.0	1.4	1.3	1.3	1.3	1.3	
20.0	1.1	1.1	1.1	1.1	1.1	
19.0	0.9	0.9	0.9	0.9	0.9	
18.0	0.7	0.7	0.7	0.7	0.7	
17.0	0.6	0.6	0.6	0.6	0.6	
16.0	0.6	0.6	0.6	0.6	0.6	

Minimum reveal (F)

NOTES

The minimum gap is the clearance required between the cabinet face and the closed door so that the door can be opened without hindrance.

Minimum reveal for doors with chamfered edges (R = 1 mm) with factory setting.

A trial fitting is recommended for door thicknesses from 24 mm.

DRILLING PATTERNS 45/9.5

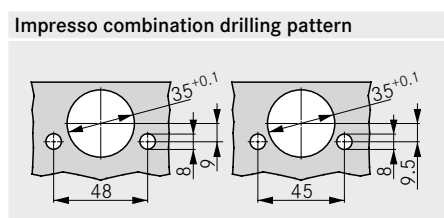
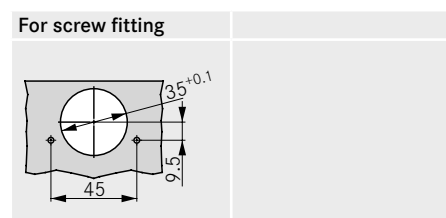

CUP DIMENSIONS

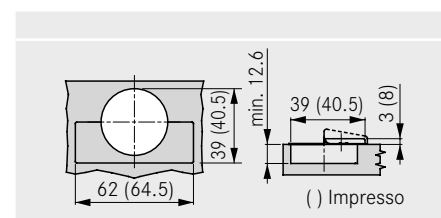

TIOMOS 110/45E

+45° corner cabinet hinge (inset)



- For 45° angled cabinets
- 110° opening angle
- With convenient depth adjustment via worm screw
- 3-dimensional adjustment with corresponding mounting plate
- Minimum reveals
- Surfaces: Nickel or Night (especially for dark cabinet materials and woods)

Available in three versions:

- With integrated damper (3 adjustable damping levels)
- Without integrated damper
- Without self-closing mechanism (without spring)

ORDER INFORMATION FOR DRILLING PATTERN 45/9.5, NICKEL

Door overlay		Damper		Without spring	Art. No.		
		With	Without		Click-on for screw fitting	Click-on for press fitting	Impresso tool-free
Inset ¹		■	-	-	F028 138534	F028 138544	F017 139340
		-	■	-	F045 138472	F045 138482	-
		-	■	■	-	F046 138604	F035 139368

¹ Cup material: steel, nickel-plated/Arm material: zamak, nickel-plated

ORDER INFORMATION FOR DRILLING PATTERN 45/9.5, NIGHT

Door overlay		Damper		Without spring	Art. No.		
		With	Without		Click-on for screw fitting		
Overlay ¹		■	-	-	F028 140418		

¹ Cup material: steel, Night/Arm material: zamak, Night

PAGE REFERENCES

Tiomos mounting plates	86	Tipmatic	114		
Accessories	96	Assembly technology	637		
Technical information	100	Assembly aids	654		

PLANNING DIMENSIONS

All dimensions in millimetres

Inset

Mounting plate height 0

Mounting plate height 14

Cross mounting plates with mounting distance 37

Door reveal	Cup distance					
	3	4	5	6	7	
1			0			
2		0			2	
3	0			2	3	
4			2	3		
5		2	3			
6	2	3				
7	3					
	Mounting plate height					
	Cross mounting plate position (X)					

Door overlay	Cup distance					
	3	4	5	6	7	
22		15.5				
21	14		15			
20			14	15	15.5	
19	12			15	15	
18		12			14	
17			12			
16				12		
15	9				12	
	Mounting plate height					
	Cross mounting plate position (X)					

Door overlay	Cup distance					
	3	4	5	6	7	
22		53.0				
21	53.0		51.5			
20			51.0	50.5	50.0	
19	52.0			50.0	49.0	
18		50.5			48.5	
17			49.0			
16				47.5		
15	49.0				46.0	
	Cross mounting plate position (X)					

MINIMUM REVEAL

Door thickness	Cup distance					
	3	4	5	6	7	
24.0	2.4	2.1	2.1	2.1	2.0	
22.0	1.6	1.6	1.6	1.5	1.5	
21.0	1.4	1.3	1.3	1.3	1.3	
20.0	1.1	1.1	1.1	1.1	1.1	
19.0	0.9	0.9	0.9	0.9	0.9	
18.0	0.7	0.7	0.7	0.7	0.7	
17.0	0.6	0.6	0.6	0.6	0.6	
16.0	0.6	0.6	0.6	0.6	0.6	
	Minimum reveal (F)					

NOTES

Minimum reveal for doors with chamfered edges (R = 1 mm) with factory setting.

A trial fitting is recommended for door thicknesses from 24 mm.

DRILLING PATTERNS 45/9.5

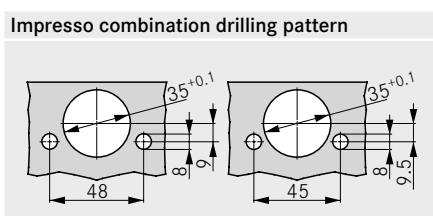
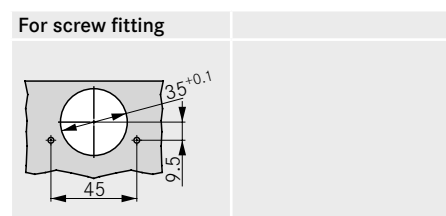

CUP DIMENSIONS

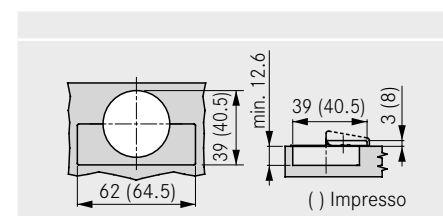

TIOMOS 120/-15A

-15° angle corner cabinet hinge (overlay)

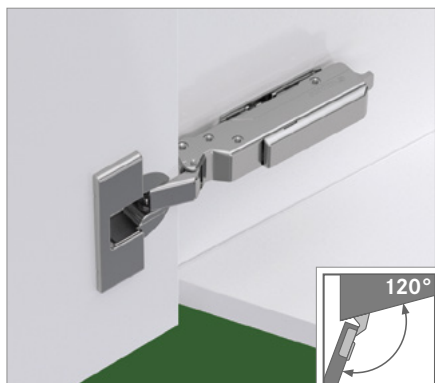

- For -15° angled cabinets
- 120° opening angle
- With convenient depth adjustment via worm screw
- 3-dimensional adjustment with corresponding mounting plate
- Minimum reveals

Available in two versions:

- With integrated damper (3 adjustable damping levels)
- Without integrated damper

ORDER INFORMATION FOR DRILLING PATTERN 45/9.5, NICKEL

Door overlay		Damper		Without spring	Art. No.		
		With	Without		Click-on for screw fitting	Click-on for press fitting	Impresso tool-free
Overlay ¹		■	-	-	F028 138555	-	F017 139347
		-	■	-	F045 138493	F045 138496	F034 139318

¹ Cup material: steel, nickel-plated/Arm material: zamak, nickel-plated

PAGE REFERENCES

Tiomos mounting plates	86
Accessories	96
Technical information	100

Assembly technology	637
Assembly aids	654

PLANNING DIMENSIONS

All dimensions in millimetres

Overlay

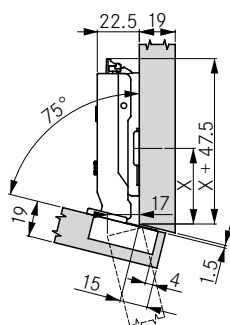

Mounting plate height 0

	Cup distance				
	3	4	5	6	7
18.0					0
17.0				0	
16.0			0		
15.0		0			
14.5				2	3
14.0	0				
13.5			2	3	
13.0					
12.5		2	3		
12.0					
11.5		3			6
11.0					
10.5	3				
10.0				6	
9.5			6		
8.5		6			
Mounting plate height					

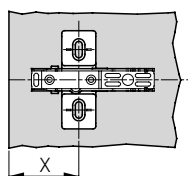

Cross mounting plates with mounting distance 37

	Mounting plate height				
	0	2	3	6	
X	40	40.5	40.5	41.5	
Cross mounting plate position (X)					

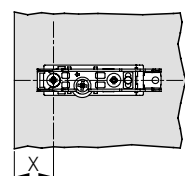

Linear mounting plates

	Mounting plate height			
	0	2	3	
X	23	23.5	23.5	
Linear mounting plate position (X)				

MINIMUM REVEAL

	Cup distance				
	3	4	5	6	7
24.0	6.4	5.4	4.4	3.4	2.4
22.0	3.0	2.0	1.5	1.5	1.5
21.0	1.4	1.3	1.3	1.3	1.3
20.0	1.1	1.1	1.1	1.1	1.1
19.0	0.9	0.9	0.9	0.9	0.9
18.0	0.7	0.7	0.7	0.7	0.7
17.0	1.0	1.0	1.0	1.0	1.5
16.0	1.0	1.0	1.0	1.0	1.0
Minimum reveal (F)					

NOTES

Minimum reveal for doors with chamfered edges (R = 1 mm) with factory setting.

We recommend a trial fitting.

DRILLING PATTERNS 45/9.5

For screw fitting

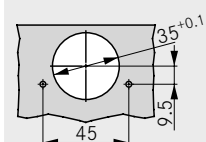

Impresso combination drilling pattern

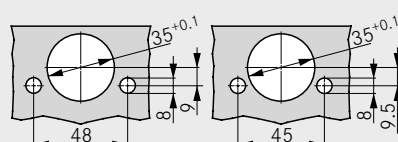

CUP DIMENSIONS

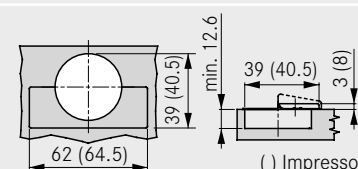

() Impresso



TIOMOS 120/-30A

-30° angle corner cabinet hinge (overlay)



- For -30° angled cabinets
- 120° opening angle
- With convenient depth adjustment via worm screw
- 3-dimensional adjustment with corresponding mounting plate
- Minimum reveals

Available in two versions:

- With integrated damper (3 adjustable damping levels)
- Without integrated damper

ORDER INFORMATION FOR DRILLING PATTERN 45/9.5, NICKEL

Door overlay		Damper		Without spring	Art. No.		
		With	Without		Click-on for screw fitting	Click-on for pressfitting	Impresso tool-free
Overlay ¹		■	-	-	F028 138556	F028 138559	F017 139348
		-	■	-	F045 138494	F045 138497	F034 139319

¹ Cup material: steel, nickel-plated/Arm material: zamak, nickel-plated

PAGE REFERENCES

Tiomos mounting plates	86	Assembly technology	637		
Accessories	96	Assembly aids	654		
Technical information	100				

PLANNING DIMENSIONS

All dimensions in millimetres

Overlay

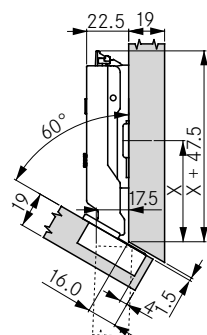

Mounting plate height 0

	Cup distance				
	3	4	5	6	7
19.0					0
18.0				0	
17.0			0		
16.5					2
16.0		0			
15.5				2	
15.0	0				3
14.5			2		
14.0				3	
13.5		2			
13.0			3		
12.5	2				
12.0		3			6
11.5					
11.0	3				6
10.5					
10.0			6		
9.0		6			
8.0	6				
Door overlay					
Mounting plate height					

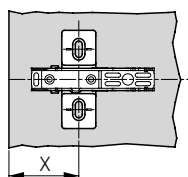

Cross mounting plates with mounting distance 37

	Mounting plate height				
	0	2	3	6	
X	53.5	55	55.5	57	
Cross mounting plate position (X)					

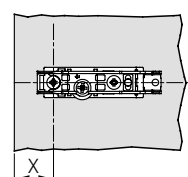

Linear mounting plates

	Mounting plate height				
	0	2	3		
X	36.5	38	38.5		
Linear mounting plate position (X)					

MINIMUM REVEAL

	Cup distance				
	3	4	5	6	7
24.0	6.4	5.4	4.4	3.4	2.4
22.0	3.0	2.0	1.5	1.5	1.5
21.0	1.4	1.3	1.3	1.3	1.3
20.0	1.1	1.1	1.1	1.1	1.1
19.0	0.9	0.9	0.9	0.9	0.9
18.0	0.7	0.7	0.7	0.7	0.7
17.0	1.0	1.0	1.0	1.0	1.5
16.0	1.0	1.0	1.0	1.0	1.0
Door thickness					
Minimum reveal (F)					

NOTES

Minimum reveal for doors with chamfered edges (R = 1 mm) with factory setting.

We recommend a trial fitting.

DRILLING PATTERNS 45/9.5

For screw fitting

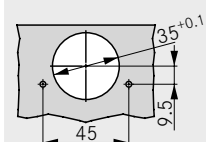

Impresso combination drilling pattern

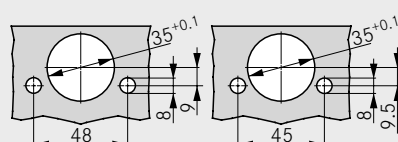

CUP DIMENSIONS

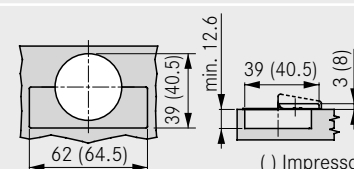

() Impresso



TIOMOS 120/-45A

-45° corner cabinet hinge (overlay)

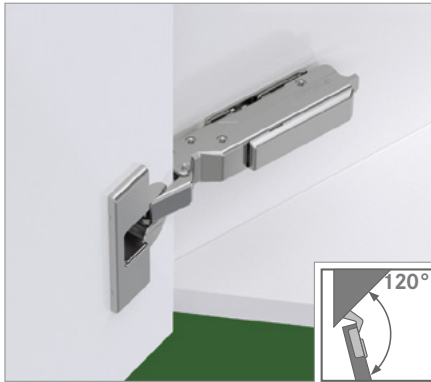

- For -45° angled cabinets
- 120° opening angle
- With convenient depth adjustment via worm screw
- 3-dimensional adjustment with corresponding mounting plate
- Minimum reveals

Available in two versions:

- With integrated damper (3 adjustable damping levels)
- Without integrated damper

ORDER INFORMATION FOR DRILLING PATTERN 45/9.5, NICKEL

Door overlay		Damper		Without spring	Art. No.		
		With	Without		Click-on for screw fitting	Click-on for press fitting	
Overlay ¹		■	-	-	F028 138557	F028 138560	
		-	■	-	F045 138495	F045 138498	

¹ Cup material: steel, nickel-plated/Arm material: zamak, nickel-plated

PAGE REFERENCES

Tiomos mounting plates	86	Assembly technology	637		
Accessories	96	Assembly aids	654		
Technical information	100				

PLANNING DIMENSIONS

All dimensions in millimetres

Overlay

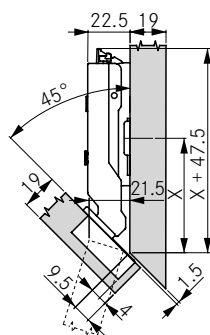

Mounting plate height 0

	Cup distance				
	3	4	5	6	7
12.0					0
11.5				0	
10.5			0		
9.5		0			2
8.5	0			2	
8.0					3
7.5			2		
7.0				3	
6.5		2			
6.0			3		
5.5	2				
5.0		3			
4.5					
4.0	3				6
3.5					
3.0				6	
2.0			6		
1.0		6			
0.0	6				
Door overlay					
Mounting plate height					

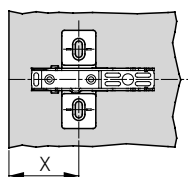

Cross mounting plates with mounting distance 37

	Mounting plate height				
	0	2	3	6	
X	60.5	62.5	63.5	66.5	
Cross mounting plate position (X)					

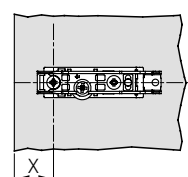

Linear mounting plates

	Mounting plate height				
	0	2	3		
X	43.5	45.5	46.5		
Linear mounting plate position (X)					

MINIMUM REVEAL

	Cup distance				
	3	4	5	6	7
24.0	6.4	5.4	4.4	3.4	2.4
22.0	3.0	2.0	1.5	1.5	1.5
21.0	1.4	1.3	1.3	1.3	1.3
20.0	1.1	1.1	1.1	1.1	1.1
19.0	0.9	0.9	0.9	0.9	0.9
18.0	0.7	0.7	0.7	0.7	0.7
17.0	1.0	1.0	1.0	1.0	1.5
16.0	1.0	1.0	1.0	1.0	1.0
Door thickness					
Minimum reveal (F)					

NOTES

Minimum reveal for doors with chamfered edges (R = 1 mm) with factory setting.

We recommend a trial fitting.

DRILLING PATTERNS 45/9.5

For screw fitting

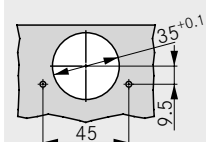

Impresso combination drilling pattern

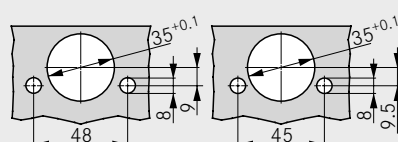

CUP DIMENSIONS

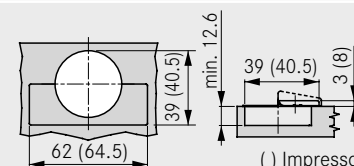

TIOMOS 100

100° refrigerator hinge

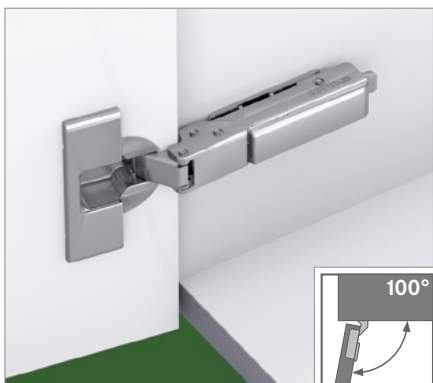

- Hinge for fridge doors (sliding system)
- 100° opening angle
- Flat hinge arm
- With self-closing mechanism (with spring)
- 3-dimensional adjustment with corresponding mounting plate

Available in one version:

- Without integrated damper

ORDER INFORMATION FOR DRILLING PATTERN 45/9.5, NICKEL

Door overlay		Cranking	Damper		Without spring	Art. No.	
			With	Without		Click-on for screw fitting	Click-on for press fitting
Overlay ¹		3	-	■	-	F045139071	F045139052

¹ Cup material: steel, nickel-plated/Arm material: zamak, nickel-plated

PAGE REFERENCES

Tiomos mounting plates	86	Assembly technology	637		
Accessories	96	Assembly aids	654		
Technical information	100				

PLANNING DIMENSIONS

All dimensions in millimetres

Overlay

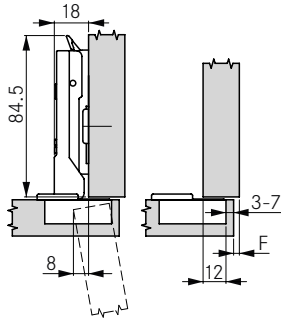

Mounting plate height 0

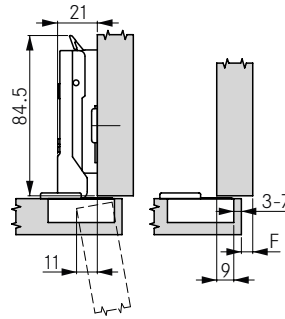

Mounting plate height 3

Door overlay	Cup distance					
	3	4	5	6	7	
21.0					-2	
20.0				-2		
19.0			-2			
18.0		-2		0		
17.0			0			
16.5	-2					
16.0		0		2	3	
15.5						
15.0	0		2	3		
14.5						
14.0		2	3			
13.5						
13.0	2	3				
12.5						
12.0	3					
	Mounting plate height					

MINIMUM GAP

Door thickness	Cup distance					
	3	4	5	6	7	
26.0	1.0	1.0	1.0	1.2	2.2	
24.0	1.0	1.0	1.0	1.0	1.8	
22.0	1.0	1.0	1.0	1.0	1.1	
20.0	1.0	1.0	1.0	1.0	1.0	
18.0	1.0	1.0	1.0	1.0	1.0	
16.0	1.0	1.0	1.0	1.0	1.0	
	Minimum gap					

MINIMUM REVEAL

Door thickness	Cup distance					
	3	4	5	6	7	
26.0	7.2	6.2	5.2	4.2	3.5	
24.0	4.8	3.8	2.8	2.3	2.2	
22.0	1.9	1.6	1.5	1.4	1.3	
20.0	0.9	0.9	0.9	0.8	0.8	
18.0	0.4	0.4	0.4	0.5	0.5	
16.0	0.3	0.3	0.3	0.3	0.3	
	Minimum reveal (F)					

NOTES

The minimum gap is the clearance required between the cabinet face and the closed door so that the door can be opened without hindrance.

Minimum reveal for doors with chamfered edges (R = 1 mm) with factory setting.

Hinge dimensions and reveal calculation with factory setting.

A trial fitting is recommended for door thicknesses from 24 mm.

DRILLING PATTERNS 45/9.5

For screw fitting

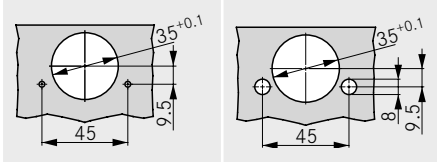

CUP DIMENSIONS

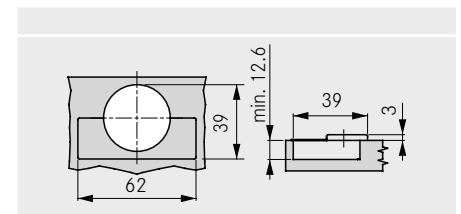

1

2

3

4

5

6

7

8

TIOMOS PCC

Pie-cut corner hinge

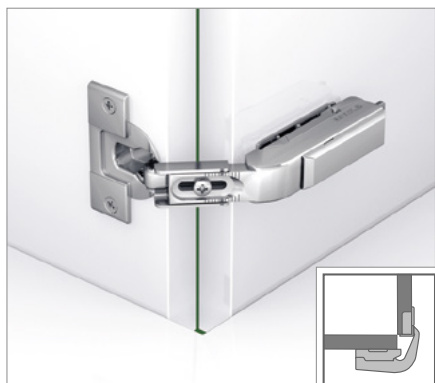

- For connecting two corner cabinet doors
- For door thicknesses up to 24 mm (factory setting for 19 mm door thickness with cup distance 3.5 mm)
- 35 mm full cup drill hole
- Shallow cup depth of 11.8 mm
- 3-dimensional adjustment with corresponding mounting plate
- Without integrated damper

Available in one version:

- Without integrated damper

ORDER INFORMATION FOR DRILLING PATTERN 45/9.5, NICKEL

Door overlay		Damper		Without spring	Art. No.	
		With	Without		Click-on for screw fitting	Click-on for press fitting
1		-	■	-	F045138517	F045138518

¹ Cup material: steel, nickel-plated/Arm material: zamak, nickel-plated

PAGE REFERENCES

Tiomos mounting plates	86
Accessories	96
Technical information	100

Assembly technology	637
Assembly aids	654

PLANNING DIMENSIONS

All dimensions in millimetres

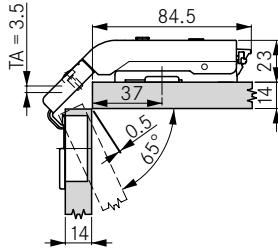

Door thickness (TS) 14 mm
Cup distance (TA) 3.5 mm
Mounting plate height 0

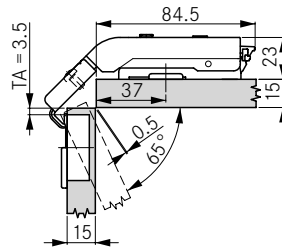

Door thickness (TS) 15 mm
Cup distance (TA) 3.5 mm
Mounting plate height 0

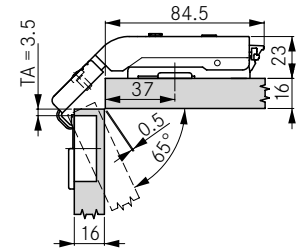

Door thickness (TS) 16 mm
Cup distance (TA) 3.5 mm
Mounting plate height 0

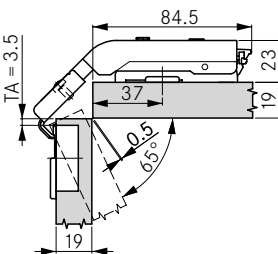

Door thickness (TS) 19 mm (factory setting)
Cup distance (TA) 3.5 mm
Mounting plate height 0

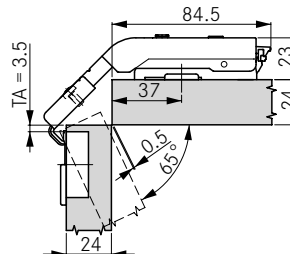

Door thickness (TS) 24 mm
Cup distance (TA) 3.5 mm
Mounting plate height 0

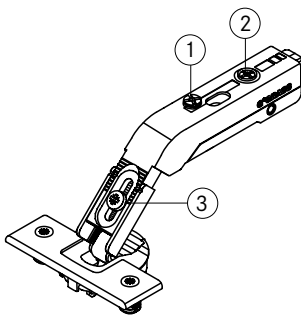

Adjustment in the hinge arm:

1. Stepless side adjustment ± 2 mm
2. Stepless depth adjustment via worm screw $+3/-2$ mm
3. Door thickness 14–24 mm (factory setting 19 mm)

Height adjustment via mounting plate

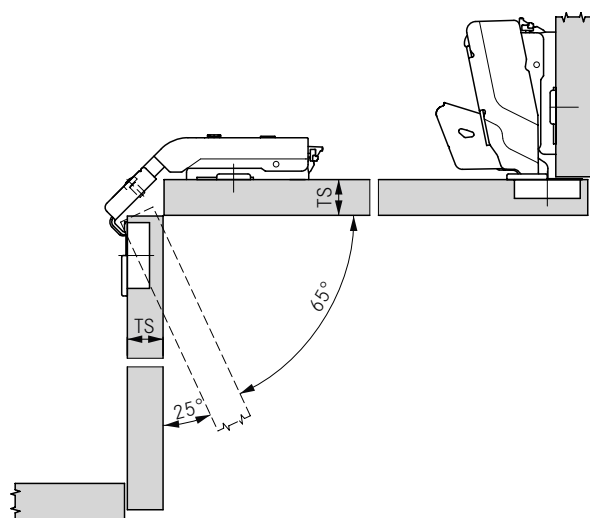

DRILLING PATTERNS 45/9.5

For screw fitting

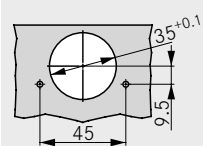

For press fitting

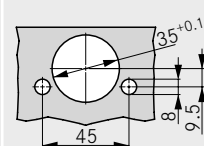

CUP DIMENSIONS

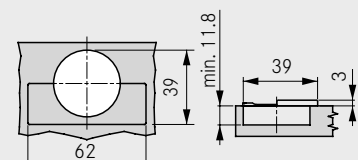

1

2

3

4

5

6

7

8