

DYNAPRO SOFT-CLOSE

Full extension slide 40/70 kg



- Excellent running characteristics
- Fully synchronised slide technology
- Soft-close damping system
- Maximum lateral stability
- Minimum drawer deflection
- Stepless self-locking of the drawer when pushed onto the slide
- Tool-free 4D adjustment facility with zamak front locking device:
 - Height adjustment + 3.5 mm
 - Tilt angle adjustment + 4 mm
 - Side adjustment ± 1.5 mm
 - Depth adjustment + 3.5 mm (optional)

ORDER INFORMATION

| 1 Dynapro full extension slide Soft-close Set: one left, one right | | | | | |
|---|------------|--|------------|--|--|
| NL | 40 kg | | 70 kg | | |
| | Art. No. | | Art. No. | | |
| 250 | F130107790 | | - | | |
| 270 | F130107793 | | - | | |
| 300 | F130107796 | | - | | |
| 320 | F130107799 | | - | | |
| 350 | F130107802 | | - | | |
| 380 | F130107805 | | - | | |
| 400 | F130107808 | | - | | |
| 420 | F130107811 | | - | | |
| 450 | F130107814 | | F130107832 | | |
| 480 | F130107817 | | - | | |
| 500 | F130107820 | | F130107838 | | |
| 520 | F130107823 | | F130107841 | | |
| 550 | F130107826 | | F130107844 | | |
| 580 | - | | F130107847 | | |
| 600 | F130107829 | | F130107850 | | |
| 650 | - | | F130107853 | | |
| 700* | - | | F130107856 | | |
| 750* | - | | F130107859 | | |

* Load capacity 50 kg

| 2 Dynapro 3D set Front locking device (2D) and adjustment adapter (1D), one left, one right | | | | | |
|--|--|--|--|--|--|
| Art. No. | | | | | |
| F134125074 | | | | | |

| Individual components | | | | | |
|---|--|------------|--|--|--|
| Description | | Art. No. | | | |
| Front locking device (2D) Set: one left, one right | | F134115305 | | | |
| Adjustment adapter (1D) Set: one left, one right | | F134115306 | | | |

| Optional: Depth adjustment (1D) for Dynapro 3D set Set: one left, one right | | | | | |
|---|--|--|--|--|--|
| Art. No. | | | | | |
| F134101313 | | | | | |

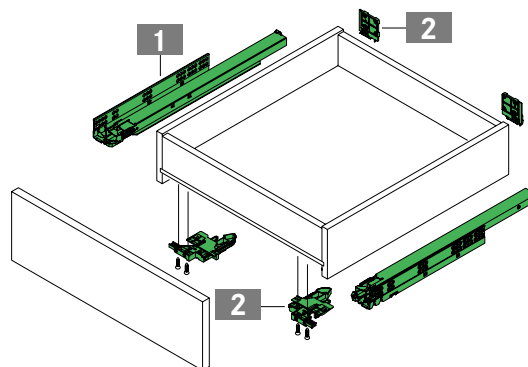

PAGE REFERENCES

| | | | | | |
|-----------------------|-----|---------------|-----|--|--|
| Pull-out shelf | 544 | Sensomatic | 617 | | |
| Application examples | 546 | Assembly aids | 668 | | |
| Technical information | 550 | | | | |

PLANNING DIMENSIONS

All dimensions in millimetres

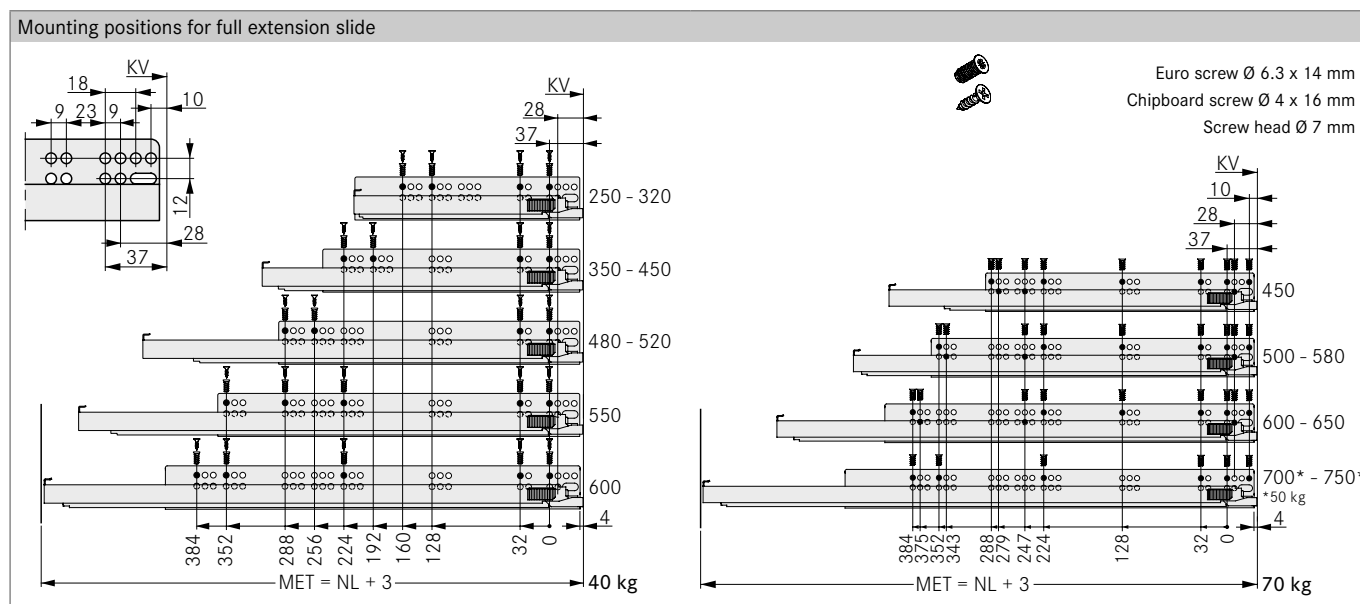
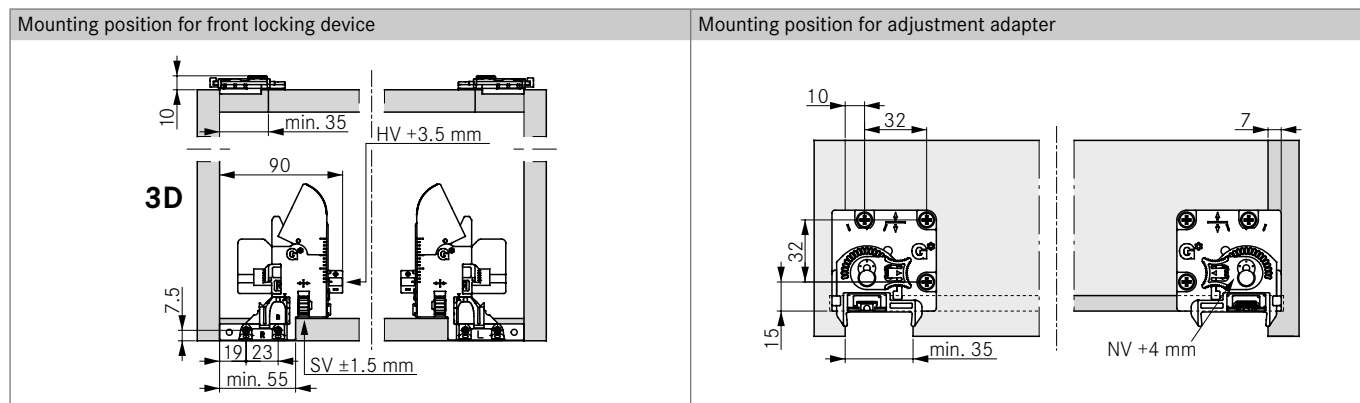
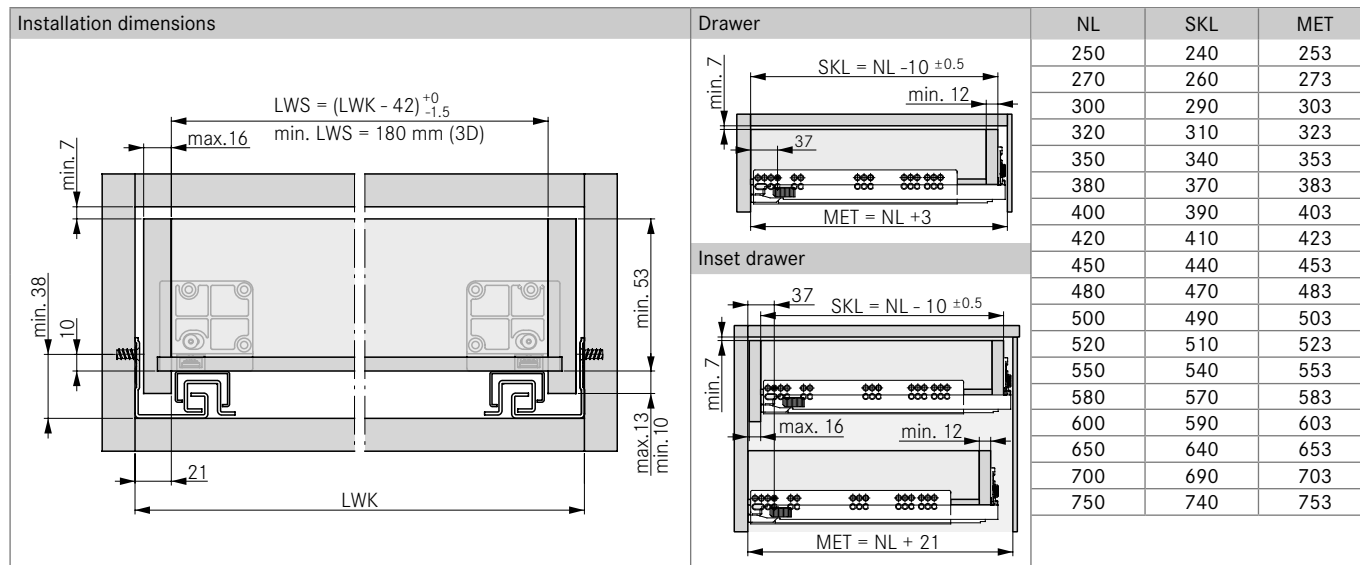

LEGEND

| | | | | | |
|-----|----------------------|-----|----------------------------|----|------------------|
| HV | Height adjustment | MET | Minimum installation depth | SV | Side adjustment |
| KV | Cabinet front edge | NL | Nominal length | TV | Depth adjustment |
| LWK | Inside cabinet width | NV | Tilt angle adjustment | | |
| LWS | Inside drawer width | SKL | Drawer length | | |

DYNAPRO SOFT-CLOSE

Full extension slide 40/70 kg

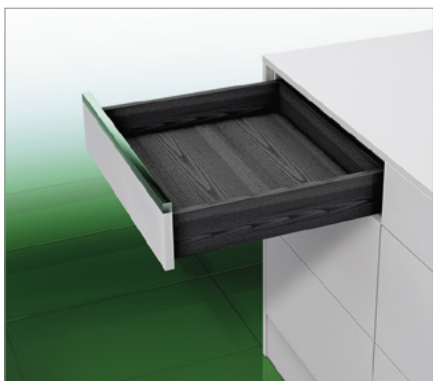

- Excellent running characteristics
- Fully synchronised slide technology
- Soft-close damping system
- Maximum lateral stability
- Minimum drawer deflection
- Stepless self-locking of the drawer when pushed onto the slide
- Tool-free 2D/3D/4D adjustment facility with plastic front locking devices:
 - Height adjustment + 3.5 mm
 - Tilt angle adjustment + 4 mm
 - Side adjustment ± 1.5 mm (3D/4D set only)
 - Depth adjustment + 3.5 mm (4D set only)

ORDER INFORMATION

| 1 Dynapro full extension slide Soft-close Set: one left, one right | | | | | |
|---|------------|--|--|------------|--|
| NL | 40 kg | | | 70 kg | |
| | Art. No. | | | Art. No. | |
| 250 | F130107790 | | | - | |
| 270 | F130107793 | | | - | |
| 300 | F130107796 | | | - | |
| 320 | F130107799 | | | - | |
| 350 | F130107802 | | | - | |
| 380 | F130107805 | | | - | |
| 400 | F130107808 | | | - | |
| 420 | F130107811 | | | - | |
| 450 | F130107814 | | | F130107832 | |
| 480 | F130107817 | | | - | |
| 500 | F130107820 | | | F130107838 | |
| 520 | F130107823 | | | F130107841 | |
| 550 | F130107826 | | | F130107844 | |
| 580 | - | | | F130107847 | |
| 600 | F130107829 | | | F130107850 | |
| 650 | - | | | F130107853 | |
| 700* | - | | | F130107856 | |
| 750* | - | | | F130107859 | |

* Load capacity 50 kg

| 2a Dynapro 4D set Front locking device (3D) and adjustment adapter (1D), one left, one right | | | | | |
|---|--|--|--|--|--|
| Art. No. | | | | | |
| F134108955 | | | | | |

| 2b Dynapro 3D set Front locking device (2D) and adjustment adapter (1D), one left, one right | | | | | |
|---|--|--|--|--|--|
| Art. No. | | | | | |
| F134108956 | | | | | |

| 2c Dynapro 2D set Front locking device (1D) and adjustment adapter (1D), one left, one right | | | | | |
|---|--|--|--|--|--|
| Art. No. | | | | | |
| F134117193 | | | | | |

| Individual components | | | | | |
|---|--|------------|--|--|--|
| Description | | Art. No. | | | |
| Front locking device (1D) Set: one left, one right | | F134140216 | | | |
| Adjustment adapter (1D) Set: one left, one right | | F134115306 | | | |
| Front locking device (2D) Set: one left, one right | | F134108949 | | | |
| Front locking device (3D) Set: one left, one right | | F134108946 | | | |
| Adjustment adapter (1D) Set: one left, one right | | F134108952 | | | |

| Optional: Depth adjustment (1D) for front locking device (2D) Set: one left, one right | | | | | |
|--|--|--|--|--|--|
| Art. No. | | | | | |
| F134108957 | | | | | |

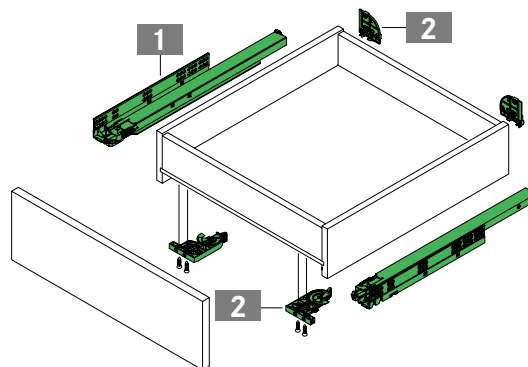

PAGE REFERENCES

| | | | | | |
|-----------------------|-----|---------------|-----|--|--|
| Pull-out shelf | 544 | Sensomatic | 617 | | |
| Application examples | 546 | Assembly aids | 668 | | |
| Technical information | 550 | | | | |

PLANNING DIMENSIONS

All dimensions in millimetres

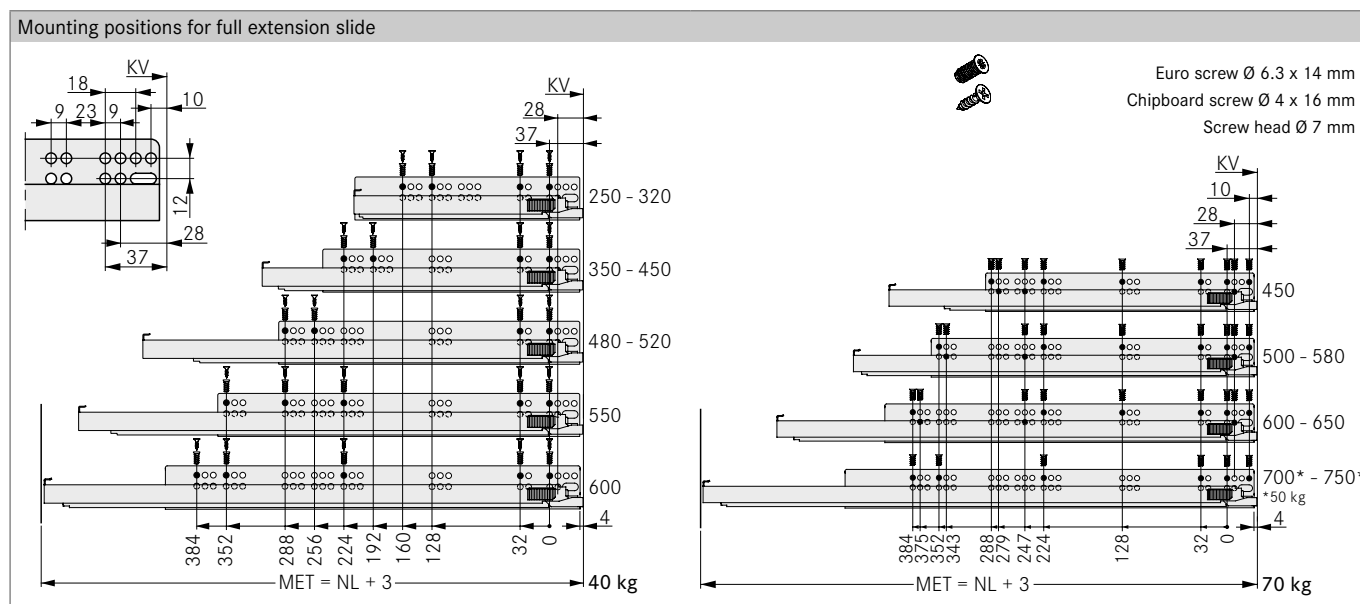
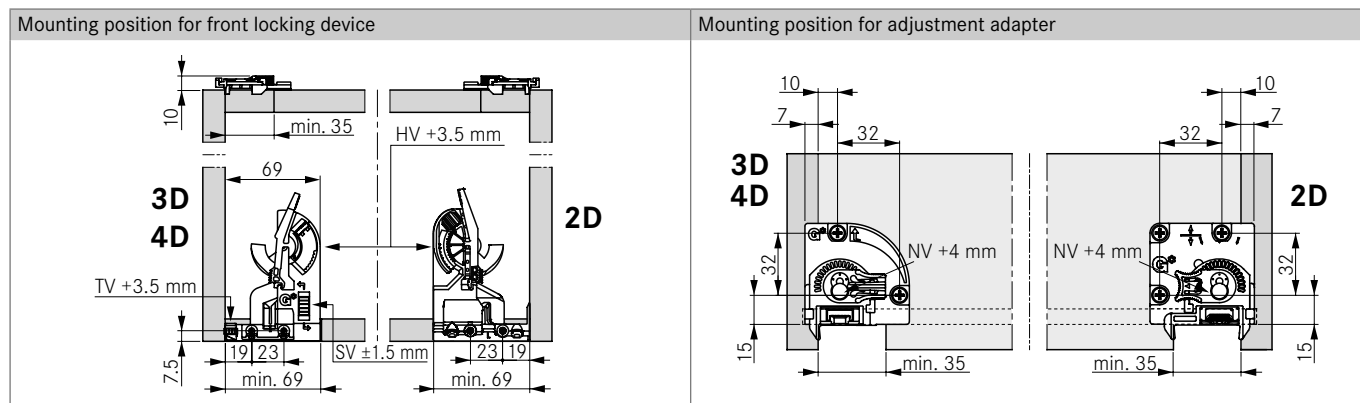
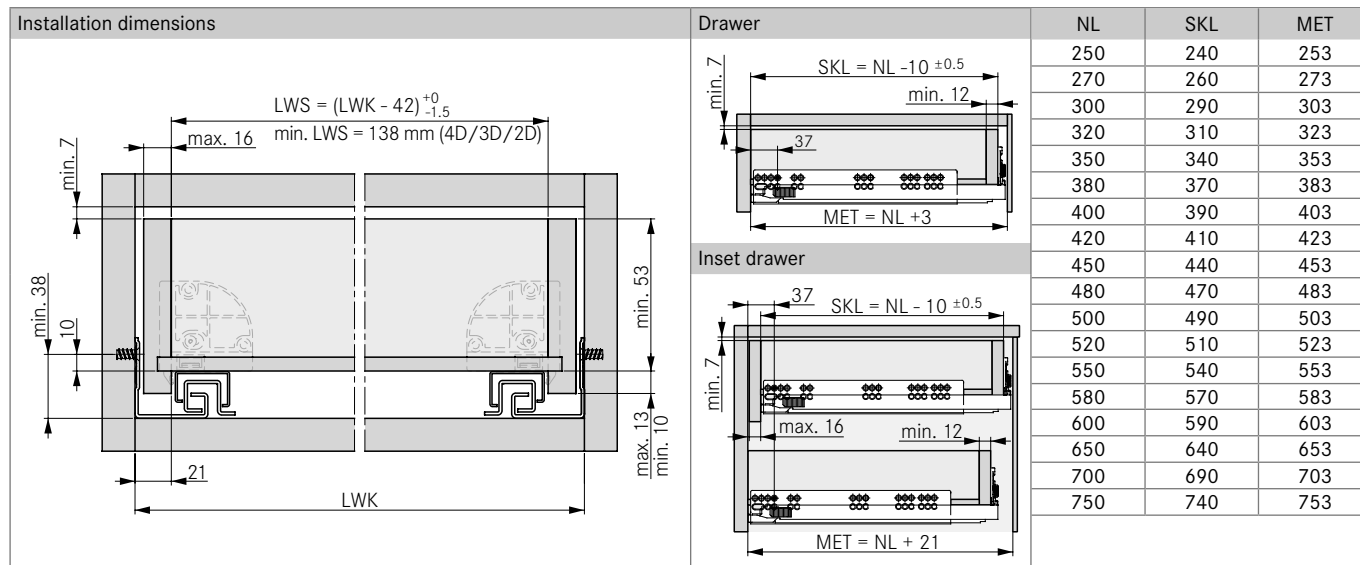

LEGEND

| | | | | | |
|-----|----------------------|-----|----------------------------|----|------------------|
| HV | Height adjustment | MET | Minimum installation depth | SV | Side adjustment |
| KV | Cabinet front edge | NL | Nominal length | TV | Depth adjustment |
| LWK | Inside cabinet width | NV | Tilt angle adjustment | | |
| LWS | Inside drawer width | SKL | Drawer length | | |

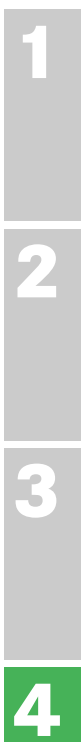

DYNAPRO TIPMATIC SOFT-CLOSE

Full extension slide 40/70 kg



- Mechanical opening system for handle-free fronts
- Combines Tipmatic function with Soft-close damper
- Tool-free installation of the Tipmatic Soft-close unit
- One unit for all nominal lengths and weight classes
- 3-stage adjustment of the opening force
- Large activation zone through synchronisation rod
- Tool-free 4D adjustment facility with Zamak front locking device:
 - Height adjustment + 3.5 mm
 - Tilt angle adjustment + 4 mm
 - Side adjustment ± 1.5 mm
 - Front gap adjustment +3/-1 mm (via Tipmatic Soft-close unit)



ORDER INFORMATION

| 1 Dynapro full extension slide Soft-close Set: one left, one right | | | | | |
|---|------------|--|------------|--|--|
| NL | 40 kg | | 70 kg | | |
| | Art. No. | | Art. No. | | |
| 270 | F130107793 | | - | | |
| 300 | F130107796 | | - | | |
| 320 | F130107799 | | - | | |
| 350 | F130107802 | | - | | |
| 380 | F130107805 | | - | | |
| 400 | F130107808 | | - | | |
| 420 | F130107811 | | - | | |
| 450 | F130107814 | | F130107832 | | |
| 480 | F130107817 | | - | | |
| 500 | F130107820 | | F130107838 | | |
| 520 | F130107823 | | F130107841 | | |
| 550 | F130107826 | | F130107844 | | |
| 580 | - | | F130107847 | | |
| 600 | F130107829 | | F130107850 | | |
| 650 | - | | F130107853 | | |
| 700* | - | | F130107856 | | |
| 750* | - | | F130107859 | | |

* Load capacity 50 kg

| 4 Synchronisation rod Single item: for cutting to length | | | | | |
|---|------------|--|--|--|--|
| L | Art. No. | | | | |
| 952 | F134109410 | | | | |
| 1562 | F102109394 | | | | |
| 1952 | F134131408 | | | | |

| Individual components | | | | | |
|---|------------|--|--|--|--|
| Description | Art. No. | | | | |
| Dynapro Tipmatic Soft-close unit Set: one left, one right | F134109324 | | | | |
| Dynapro Tipmatic Soft-close activator Set: one left, one right | F134109325 | | | | |
| Front locking device (2D) Set: one left, one right | F134115305 | | | | |
| Adjustment adapter (1D) Set: one left, one right | F134115306 | | | | |

| 2 Dynapro 3D set Front locking device (2D) and adjustment adapter (1D), one left, one right | | | | | |
|--|--|--|--|--|--|
| Art. No. | | | | | |
| F134125074 | | | | | |

| 3 Dynapro Tipmatic Soft-close (1D) Set: unit and activator, one left, one right | | | | | |
|---|--|--|--|--|--|
| Art. No. | | | | | |
| F134109323 | | | | | |

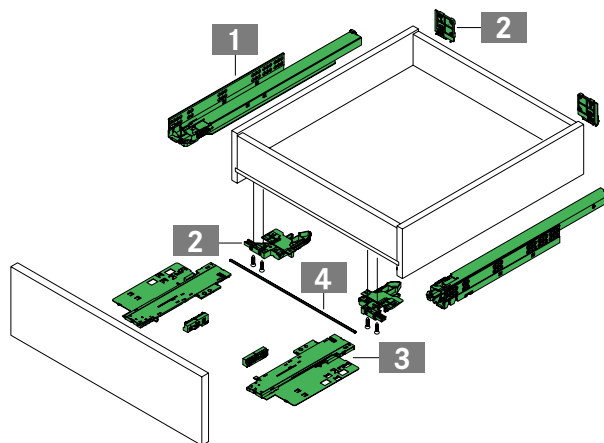

PAGE REFERENCES

| | | | | | |
|-----------------------|-----|---------------|-----|--|--|
| Pull-out shelf | 544 | Assembly aids | 668 | | |
| Application examples | 546 | | | | |
| Technical information | 550 | | | | |

PLANNING DIMENSIONS

All dimensions in millimetres

Installation dimensions

$LWS = (LWK - 42)_{-1.5}^{+0}$
min. LWS = 226 mm

min. 7, max. 16, min. 38, min. 53, max. 13, min. 10, 21, LWK, min. LWK = 268

Drawer

$SKL = NL - 10 \pm 0.5$
min. 2.5, min. 12, 37, MET = NL + 3, min. 7

Inset drawer

$SKL = NL - 10 \pm 0.5$
min. 2.5, max. 16, min. 12, MET = NL + 21, min. 7

| | NL | SKL | MET |
|--|-----|-----|-----|
| | 270 | 260 | 273 |
| | 300 | 290 | 303 |
| | 320 | 310 | 323 |
| | 350 | 340 | 353 |
| | 380 | 370 | 383 |
| | 400 | 390 | 403 |
| | 420 | 410 | 423 |
| | 450 | 440 | 453 |
| | 480 | 470 | 483 |
| | 500 | 490 | 503 |
| | 520 | 510 | 523 |
| | 550 | 540 | 553 |
| | 580 | 570 | 583 |
| | 600 | 590 | 603 |
| | 650 | 640 | 653 |
| | 700 | 690 | 703 |
| | 750 | 740 | 753 |

Cutting dimensions for synchronisation rod

LWK - 216

Mounting position for front locking device

10, min. 35, HV + 3.5 mm, 90, 7.5, 19, 23, min. 55, SV ± 1.5 mm

Mounting position for adjustment adapter

10, 32, 32, min. 35, NV + 4 mm

Position for the synchronisation rod

| NL | A | B |
|-----------|-----|-----|
| 270 - 320 | 248 | 265 |
| 350 - 750 | 283 | 300 |

Mounting positions for full extension slide

18, KV, 9, 23, 9, 10, 12, 28, 37, 270 - 320, 350 - 450, 480 - 520, 550, 600, 700* - 750*
50 kg, 40 kg, 70 kg, 384, 352, 288, 256, 224, 192, 160, 128, 32, 0, 4, MET = NL + 3, 28, 37, KV, 10, 28, 37, 450, 500 - 580, 600 - 650, 700 - 750*
*50 kg, 384, 375, 352, 343, 288, 279, 247, 224, 128, 32, 0, 4, MET = NL + 3

Euro screw $\varnothing 6.3 \times 14$ mm
Chipboard screw $\varnothing 4 \times 16$ mm
Screw head $\varnothing 7$ mm

LEGEND

| | | | | | |
|-----|----------------------|-----|----------------------------|-----|-----------------|
| HV | Height adjustment | LWS | Inside drawer width | SKL | Drawer length |
| KV | Cabinet front edge | MET | Minimum installation depth | SV | Side adjustment |
| L | Length | NL | Nominal length | | |
| LWK | Inside cabinet width | NV | Tilt angle adjustment | | |

DYNAPRO TIPMATIC

Full extension slide 40/60 kg



- Full extension slide Tipmatic for handle-free fronts
- Tipmatic opening unit integrated into the slide
- Excellent running characteristics
- Fully synchronised slide technology
- Maximum lateral stability
- Minimum drawer deflection
- Tool-free 4D adjustment facility with Zamak front locking device:
 - Height adjustment + 3.5 mm
 - Tilt angle adjustment + 4 mm
 - Side adjustment ± 1.5 mm
 - Front gap adjustment + 1.5 mm (via Tipmatic slide)

ORDER INFORMATION

| 1 Dynapro full extension slide Tipmatic Set: one left, one right | | | | |
|---|------------|--|------------|--|
| NL | 40 kg | | 60 kg | |
| | Art. No. | | Art. No. | |
| 250 | F130117458 | | - | |
| 270 | F130117459 | | - | |
| 300 | F130117460 | | - | |
| 320 | F130117461 | | - | |
| 350 | F130117462 | | - | |
| 380 | F130116955 | | - | |
| 400 | F130117463 | | - | |
| 420 | F130117464 | | - | |
| 450 | F130117465 | | F130117470 | |
| 480 | F130117466 | | - | |
| 500 | F130117467 | | F130117471 | |
| 520 | F130116956 | | F130116957 | |
| 550 | F130117468 | | F130117472 | |
| 580 | - | | F130117473 | |
| 600 | - | | F130116941 | |
| 650 | - | | F130117474 | |
| 700* | - | | F130117534 | |
| 750* | - | | F130117535 | |

* Load capacity 50 kg

| 2 Dynapro 3D set Front locking device (2D) and adjustment adapter (1D), one left, one right | | | | |
|--|------------|--|--|--|
| | Art. No. | | | |
| | F134125074 | | | |

| 3 Synchronisation unit Set: synchronisation module and synchronisation lever, one left, one right | | | | |
|--|------------|--|------------|--|
| | 40 kg | | 60 kg | |
| | Art. No. | | Art. No. | |
| | F134117475 | | F134117476 | |

| 4 Synchronisation rod Single item: for cutting to length | | | | |
|---|------------|--|--|--|
| L | Art. No. | | | |
| 981 | F134116947 | | | |

| Individual components | | | | |
|---|------------|--|--|--|
| Description | Art. No. | | | |
| Front locking device (2D) Set: one left, one right | F134115305 | | | |
| Adjustment adapter (1D) Set: one left, one right | F134115306 | | | |

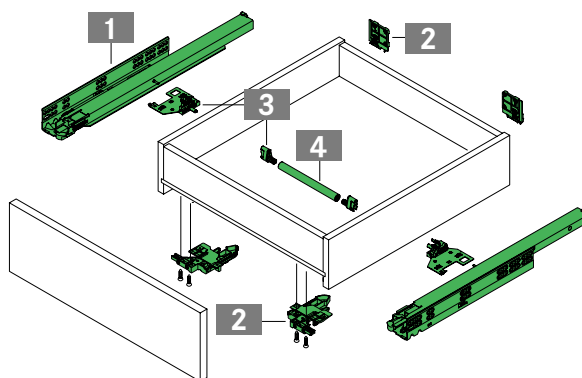

PAGE REFERENCES

| | | | | | |
|-----------------------|-----|---------------|-----|--|--|
| Pull-out shelf | 544 | Assembly aids | 668 | | |
| Application examples | 546 | | | | |
| Technical information | 550 | | | | |

PLANNING DIMENSIONS

All dimensions in millimetres

Installation dimensions

Drawer

Inset drawer

| NL | SKL | MET |
|-----|-----|-----|
| 250 | 240 | 253 |
| 270 | 260 | 273 |
| 300 | 290 | 303 |
| 320 | 310 | 323 |
| 350 | 340 | 353 |
| 380 | 370 | 383 |
| 400 | 390 | 403 |
| 420 | 410 | 423 |
| 450 | 440 | 453 |
| 480 | 470 | 483 |
| 500 | 490 | 503 |
| 520 | 510 | 523 |
| 550 | 540 | 553 |
| 580 | 570 | 583 |
| 600 | 590 | 603 |
| 650 | 640 | 653 |
| 700 | 690 | 703 |
| 750 | 740 | 753 |

Cutting dimensions for synchronisation rod

Mounting position for front locking device

Mounting position for adjustment adapter

Position for the synchronisation rod

| NL | A |
|-----------|-----|
| 250 - 320 | 205 |
| 350 - 750 | 241 |

Mounting positions for full extension slide

Euro screw \varnothing 6.3 x 14 mm
Chipboard screw \varnothing 4 x 16 mm
Screw head \varnothing 7 mm

LEGEND

| | | | | | |
|-----|----------------------|-----|----------------------------|-----|-----------------|
| HV | Height adjustment | LWS | Inside drawer width | SKL | Drawer length |
| KV | Cabinet front edge | MET | Minimum installation depth | SV | Side adjustment |
| L | Length | NL | Nominal length | | |
| LWK | Inside cabinet width | NV | Tilt angle adjustment | | |

DYNAPRO

For base panel mounting and pull-out shelf

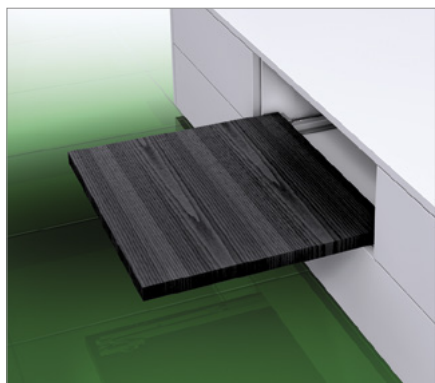

Dynapro for base panel mounting:

- Synchronised full extension slide, 40 kg load capacity
- Soft-close damper system
- Assembly on the cabinet or shelf
- Particularly suitable for pull-out shelves (no lateral screw-on angles)

Shelf clip set:

- Height adjustment + 3.5 mm
- Optional depth adjustment + 3.5 mm
- Stepless self-locking of shelf on slide
- Compatible with all Dynapro slides

ORDER INFORMATION

| 1 | | Dynapro full extension slide Soft-close for base panel mounting | | | |
|----------|-------------------|--|--|--|--|
| | | Set: one left, one right | | | |
| NL | 40 kg | | | | |
| | Art. No. | | | | |
| 400 | F130107878 | | | | |
| 450 | F130107884 | | | | |
| 500 | F130107890 | | | | |
| 550 | F130107893 | | | | |

| 2 | | Dynapro 1D set | | | |
|----------|-------------------|--|--|--|--|
| | | Front locking device (1D) and shelf clip, one left, one right | | | |
| | Art. No. | | | | |
| | F134107411 | | | | |

| Individual components | | | | | |
|--|-------------------|--|--|--|--|
| Description | Art. No. | | | | |
| Front locking device (1D) | F134140216 | | | | |
| Set: one left, one right | | | | | |
| Shelf clip | F134101305 | | | | |
| Single item: can be used on left/right | | | | | |

| Optional: depth adjustment (1D) | | | | | |
|--|-------------------|---------------------------------|--|--|--|
| | | Set: one left, one right | | | |
| | Art. No. | | | | |
| | F134101313 | | | | |

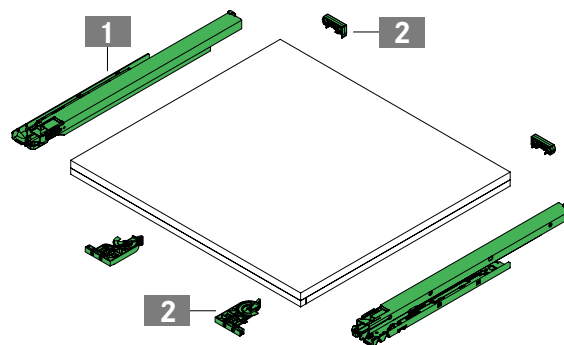

PAGE REFERENCES

| | |
|-----------------------------|-----|
| Dynapro Soft-close | 536 |
| Dynapro Tipmatic Soft-close | 540 |
| Dynapro Tipmatic | 542 |

| | |
|-----------------------|-----|
| Application examples | 546 |
| Technical information | 550 |
| Assembly aids | 668 |

| | |
|--|--|
| | |
| | |
| | |

PLANNING DIMENSIONS

All dimensions in millimetres

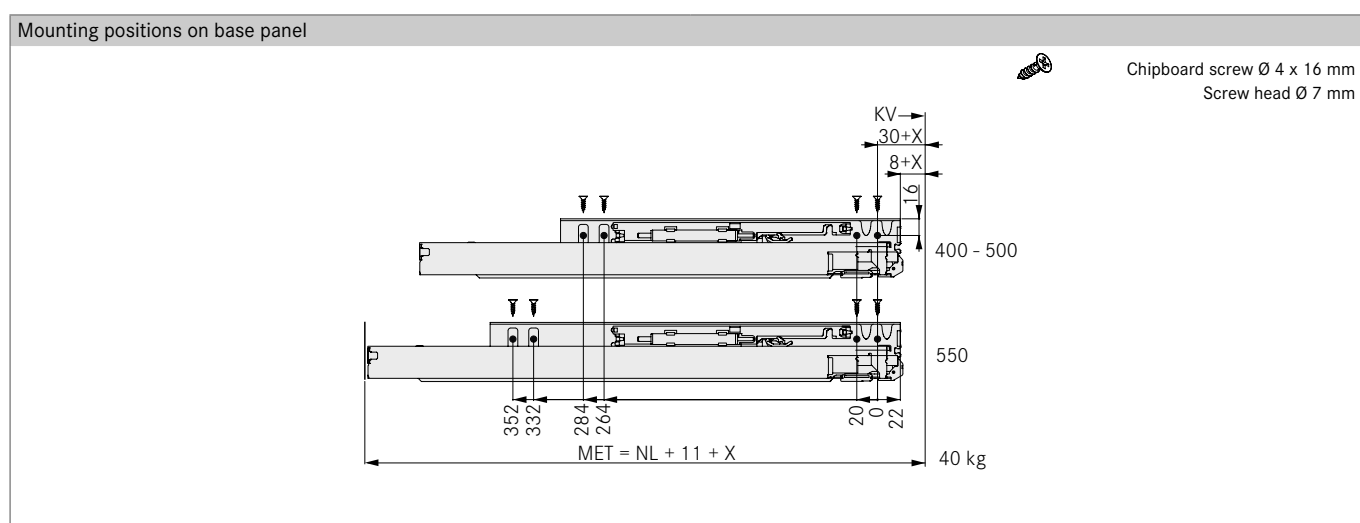
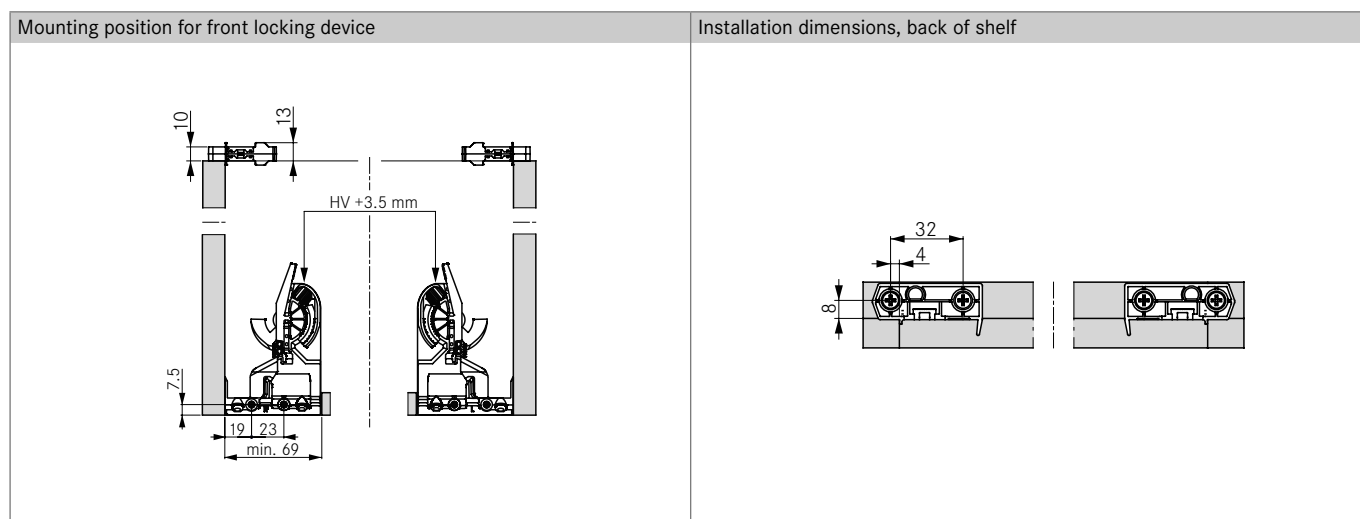
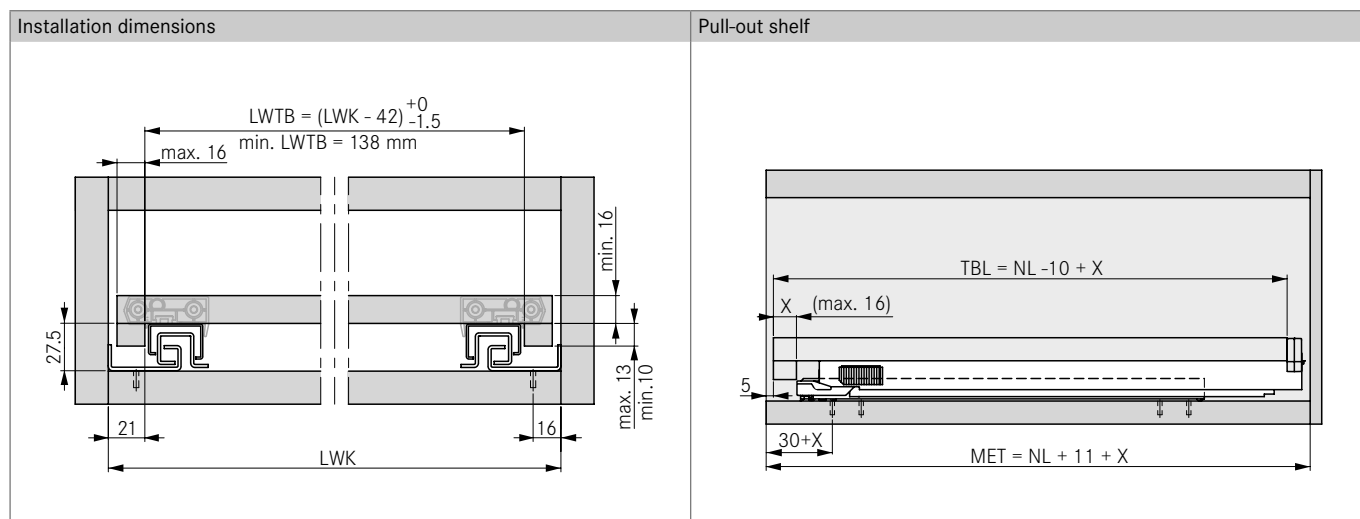

LEGEND

| | |
|------|----------------------------|
| HV | Height adjustment |
| LWK | Inside cabinet width |
| LWTB | Inside shelf width |
| MET | Minimum installation depth |

| | |
|-----|----------------|
| NL | Nominal length |
| TBL | Shelf length |



APPLICATION EXAMPLES

Dynapro Tipmatic Soft-close in double cabinet

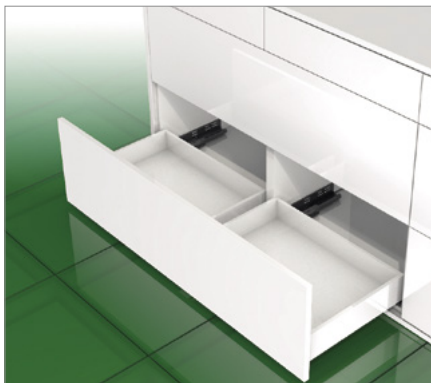

- Two drawers with one continuous front panel can be opened using Dynapro Tipmatic Soft-close
- Allows implementation of wide, handle-free fronts with a mechanical opening system
- Enables puristic and solid furniture design in new dimensions
- Large activation zone through synchronisation rod
- Tool-free 5D adjustment facility

Note:

- Minimum outside width: 1000 mm
- Maximum outside width: 2200 mm
- Maximum total weight: 40 kg
- Only the Dynapro slides on the outer walls of the double cabinet are fitted with a Tipmatic Soft-close unit and an activator.
- The Soft-close unit must be removed for Dynapro slides on the inner walls of the double cabinet

ORDER INFORMATION

| 1 Dynapro full extension slide Soft-close Set: one left, one right | | | | | |
|---|------------|--|--|--|--|
| NL | 40 kg | | | | |
| | Art. No. | | | | |
| 270 | F130107793 | | | | |
| 300 | F130107796 | | | | |
| 320 | F130107799 | | | | |
| 350 | F130107802 | | | | |
| 380 | F130107805 | | | | |
| 400 | F130107808 | | | | |
| 420 | F130107811 | | | | |
| 450 | F130107814 | | | | |
| 480 | F130107817 | | | | |
| 500 | F130107820 | | | | |
| 520 | F130107823 | | | | |
| 550 | F130107826 | | | | |
| 600 | F130107829 | | | | |

| 3 Dynapro Tipmatic Soft-close (1D) Set: unit and activator, one left, one right | | | | | |
|--|------------|--|--|--|--|
| | Art. No. | | | | |
| | F134109323 | | | | |

| 4 Synchronisation rod Single item: for cutting to length | | | | | |
|---|------------|--|--|--|--|
| L | Art. No. | | | | |
| 952 | F134109410 | | | | |
| 1562 | F102109394 | | | | |
| 1952 | F134131408 | | | | |

| 2 Dynapro accessories for double cabinet Set: front locking device (2D) (4x), adjustment adapter (2D) (2x) and adjustment adapter (1D) (2x) | | | | | |
|--|------------|--|--|--|--|
| | Art. No. | | | | |
| | F134136776 | | | | |

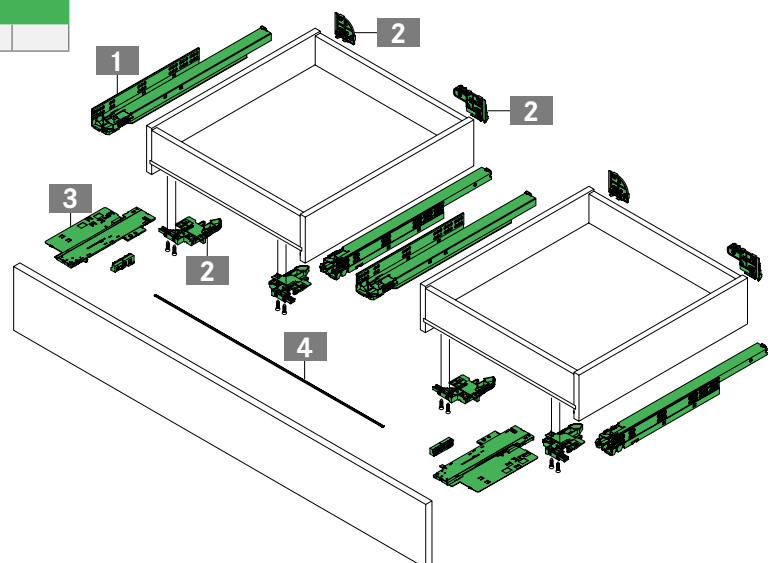

PAGE REFERENCES

| | | | | | |
|-----------------------------|-----|-----------------------|-----|--|--|
| Dynapro Soft-close | 536 | Pull-out shelf | 544 | | |
| Dynapro Tipmatic Soft-close | 540 | Technical information | 550 | | |
| Dynapro Tipmatic | 542 | Assembly aids | 668 | | |

PLANNING DIMENSIONS

All dimensions in millimetres

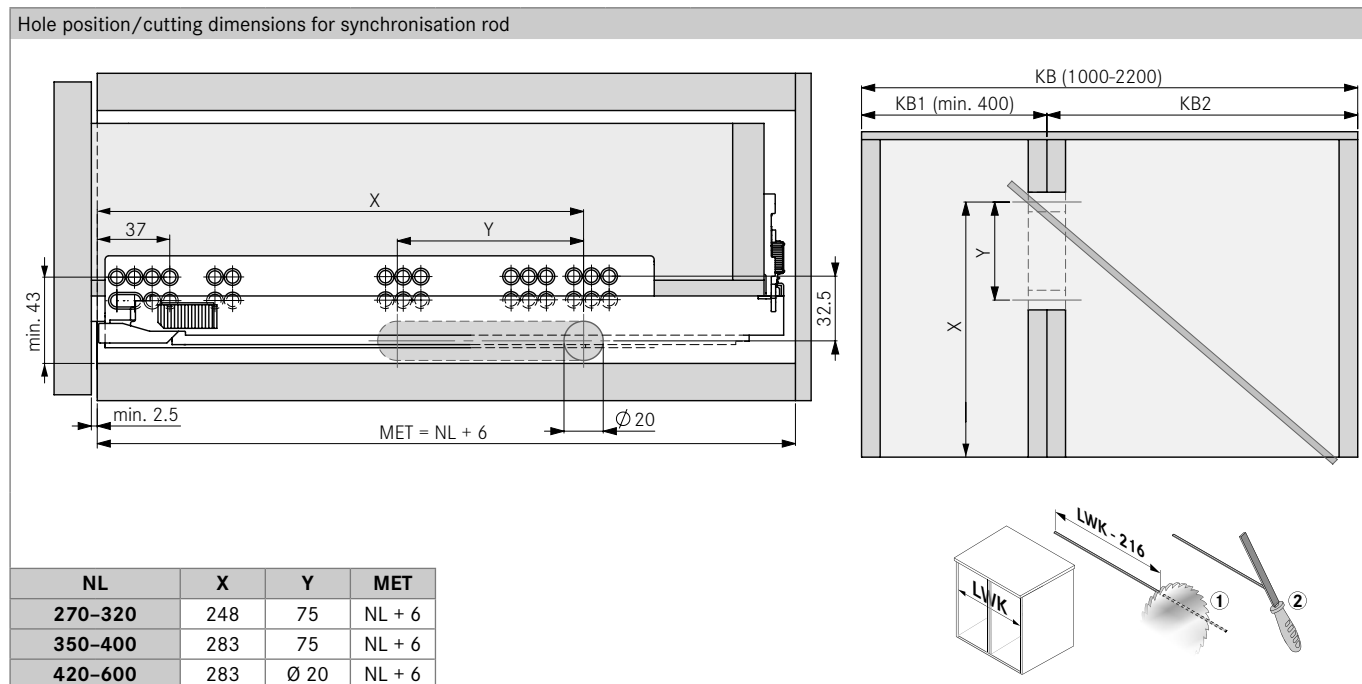
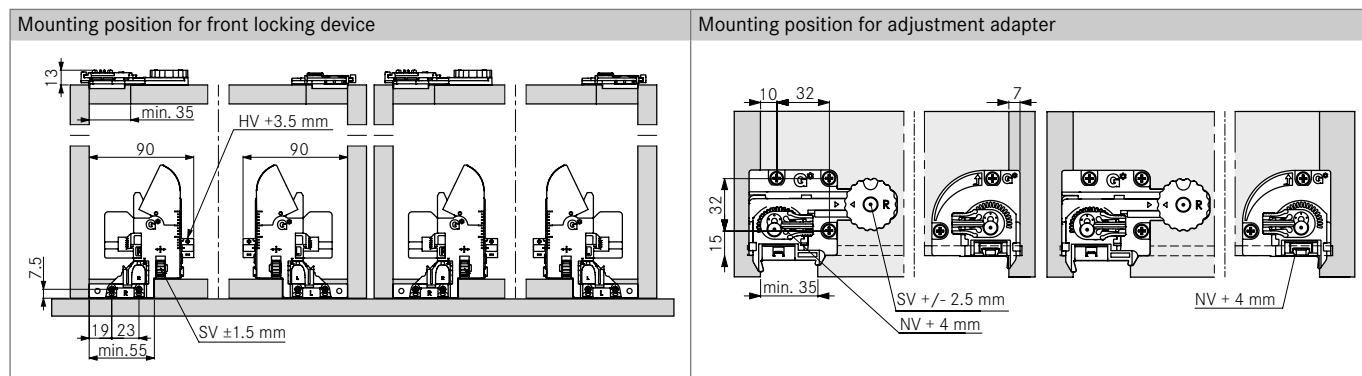
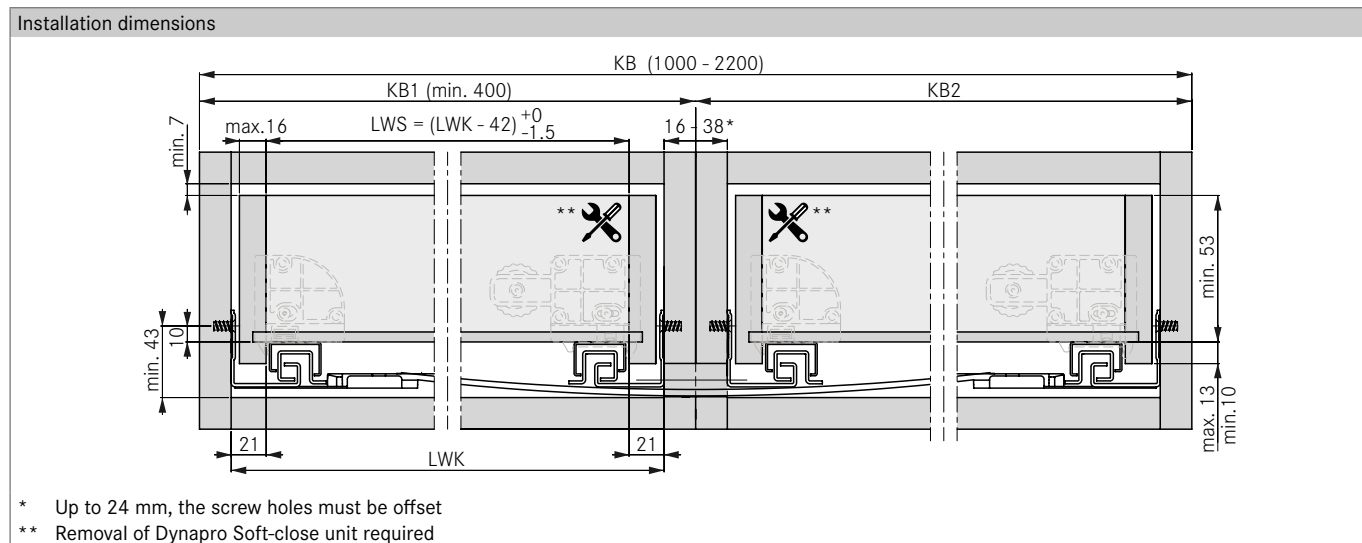

LEGEND

| | |
|-----|----------------------|
| HV | Height adjustment |
| KB | Cabinet width |
| L | Length |
| LWK | Inside cabinet width |

| | |
|-----|----------------------------|
| LWS | Inside drawer width |
| MET | Minimum installation depth |
| NL | Nominal length |
| NV | Tilt angle adjustment |

| | |
|----|-----------------|
| SV | Side adjustment |
|----|-----------------|



APPLICATION EXAMPLES

Extra-wide drawer

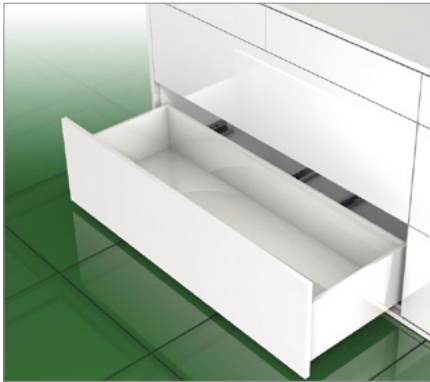

- Extra-wide drawer for cabinet without additional centre wall
- Modern furniture design with large fronts and no lost storage space
- Ideal for living room storage systems or bed drawers
- Made possible thanks to the combination of standard Dynapro slides with Dynapro for base panel mounting

ORDER INFORMATION

| | | | | | |
|----------|--|--|--|--|--|
| 1 | | Dynapro full extension slide Soft-close | | | |
| | | Set: one left, one right | | | |
| NL | | 40 kg | | | |
| | | Art. No. | | | |
| 400 | | F130107808 | | | |
| 450 | | F130107814 | | | |
| 500 | | F130107820 | | | |
| 550 | | F130107826 | | | |

| | | | | | |
|----------|--|---|--|--|--|
| 3 | | Dynapro 3D set | | | |
| | | Front locking device (2D) and adjustment adapter (1D), one left, one right | | | |
| | | Art. No. | | | |
| | | F134125074 | | | |

| | | | | | |
|----------|--|--|--|--|--|
| 2 | | Dynapro full extension slide Soft-close for base panel mounting | | | |
| | | Set: one left, one right | | | |
| NL | | 40 kg | | | |
| | | Art. No. | | | |
| 400 | | F130107878 | | | |
| 450 | | F130107884 | | | |
| 500 | | F130107890 | | | |
| 550 | | F130107893 | | | |

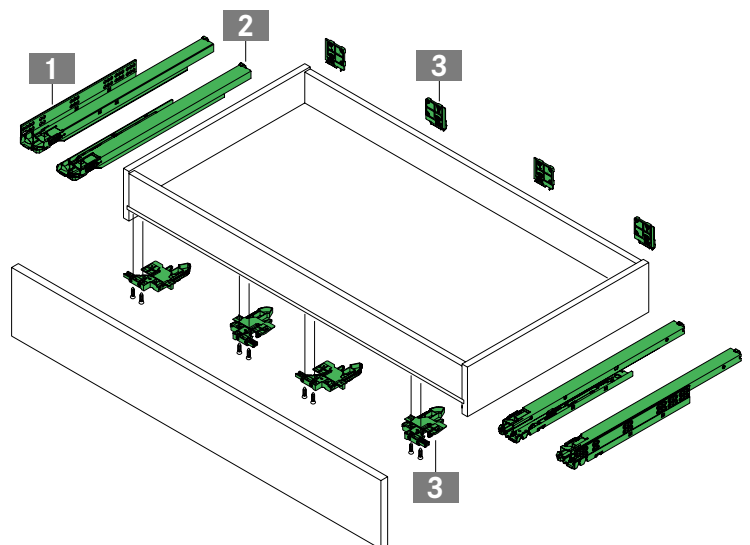

PAGE REFERENCES

| | | | | | |
|-----------------------------|-----|-----------------------|-----|--|--|
| Dynapro Soft-close | 536 | Pull-out shelf | 544 | | |
| Dynapro Tipmatic Soft-close | 540 | Technical information | 550 | | |
| Dynapro Tipmatic | 542 | Assembly aids | 668 | | |

PLANNING DIMENSIONS

All dimensions in millimetres

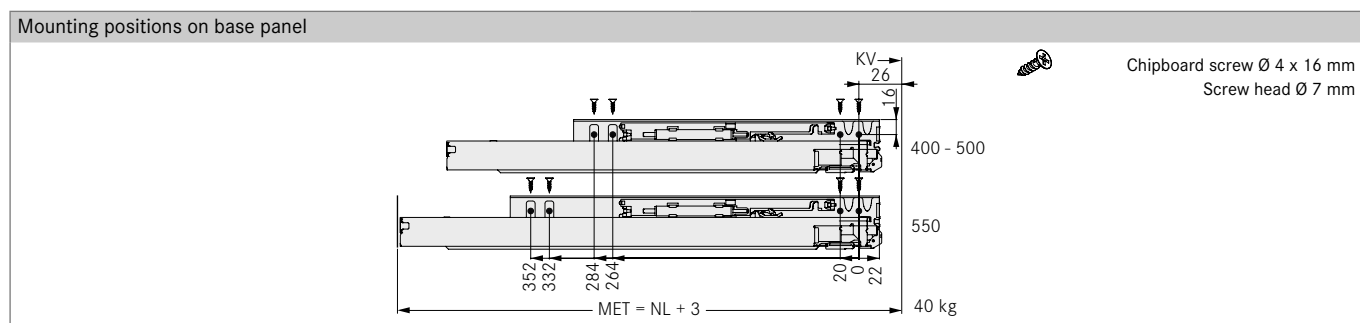
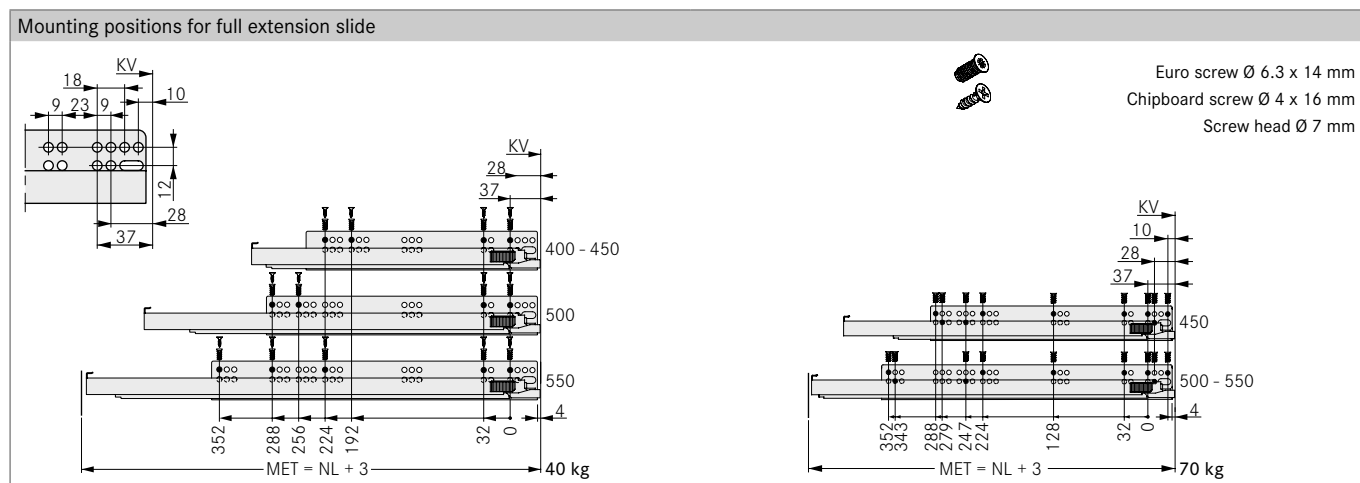
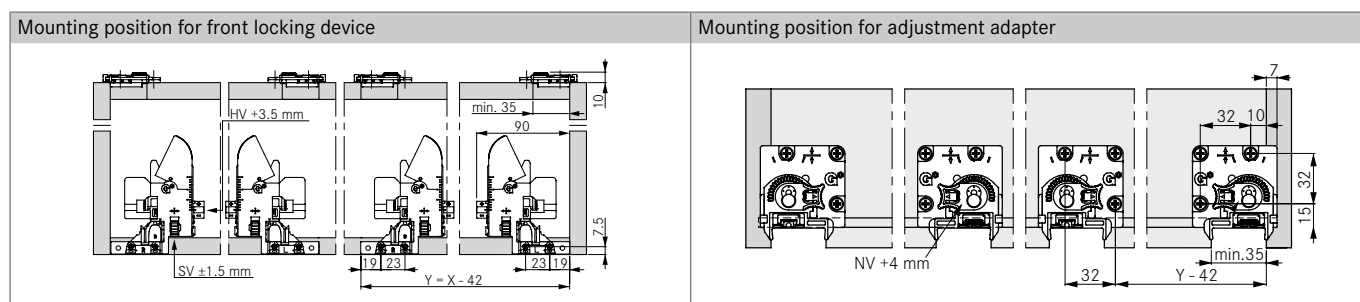
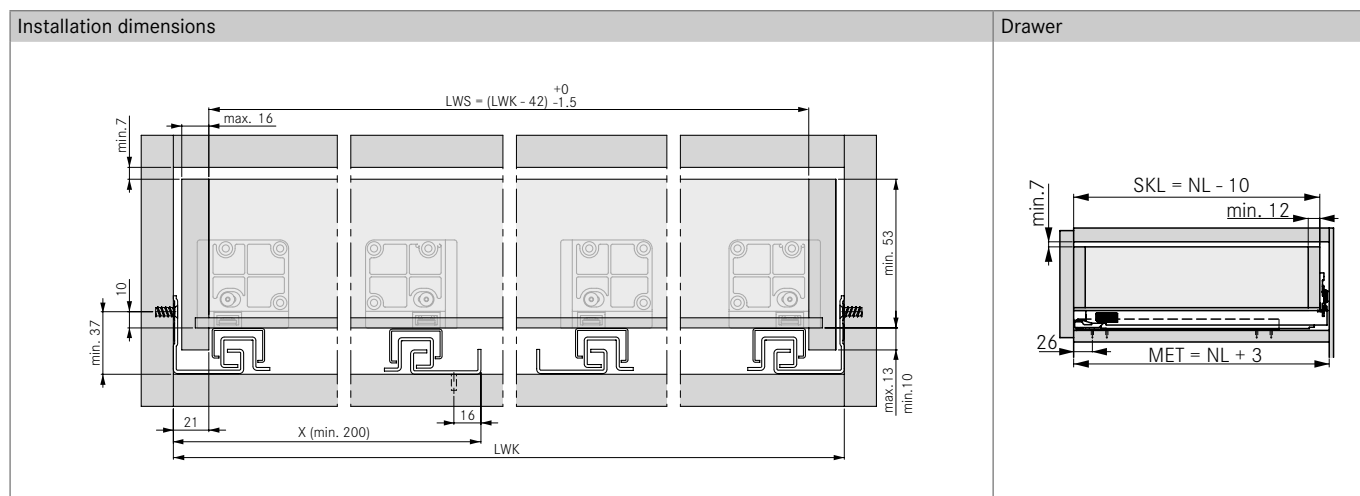

LEGEND

| | | | | | |
|----|--------------------|-----|----------------------------|-----|-----------------------|
| HV | Height adjustment | LWK | Inside cabinet width | NV | Tilt angle adjustment |
| KB | Cabinet width | LWS | Inside drawer width | SKL | Drawer length |
| KV | Cabinet front edge | MET | Minimum installation depth | SV | Side adjustment |
| L | Length | NL | Nominal length | | |



DYNAPRO

Technical information

PLANNING DIMENSIONS

Inserting the drawer

Place the drawer on the extended Dynapro slides and slide in until it audibly engages.

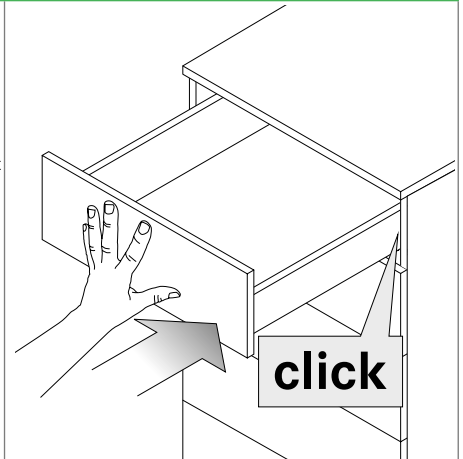
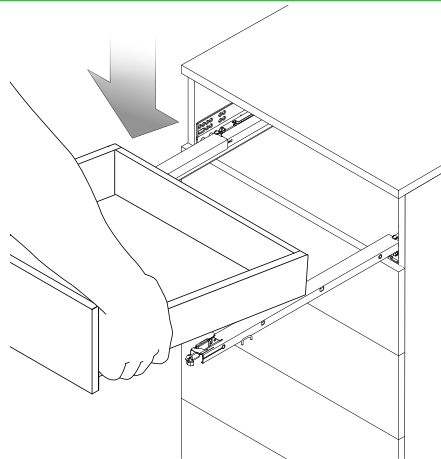

Removing the drawer

Pull out the drawer, actuate the lever of the front locking device on both sides and pull the drawer forwards, away from the slide.

Dynapro 3D/4D

Dynapro 2D

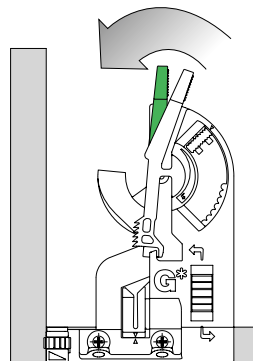
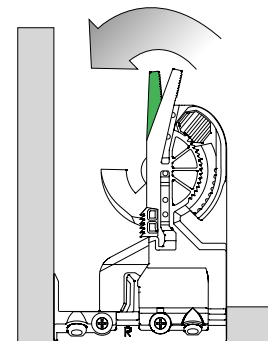
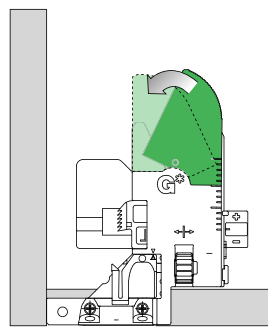

NOTES



Mounting of cabinet members:

The screw recommendations are intended for reference. Screw head \varnothing 7 mm. Assemblers must ensure that the substrate material is thick enough.

PAGE REFERENCES

| | | | | | |
|-----------------------------|-----|----------------------|-----|---------------|-----|
| Dynapro Soft-close | 536 | Pull-out shelf | 544 | Assembly aids | 668 |
| Dynapro Tipmatic Soft-close | 540 | Application examples | 546 | | |
| Dynapro Tipmatic | 542 | Sensomatic | 617 | | |

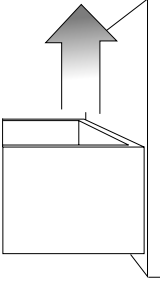
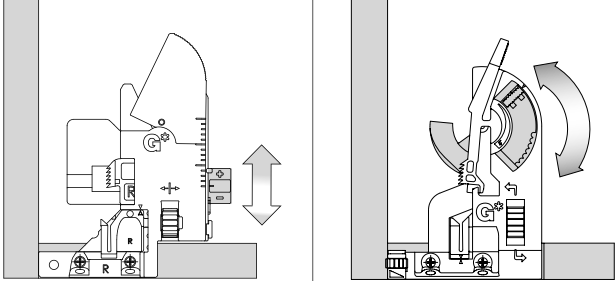
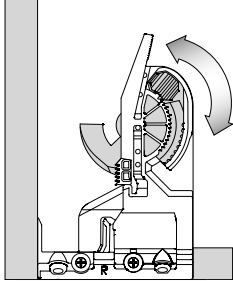
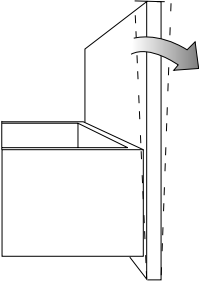
ADJUSTMENT

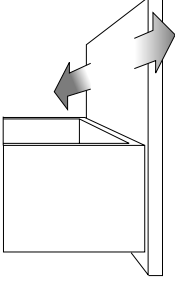
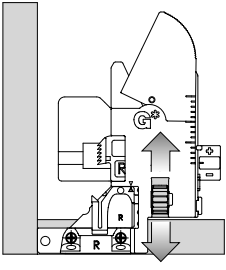
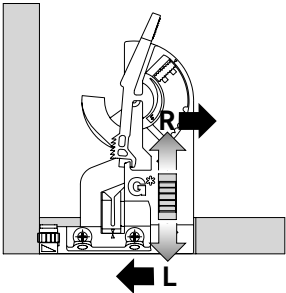
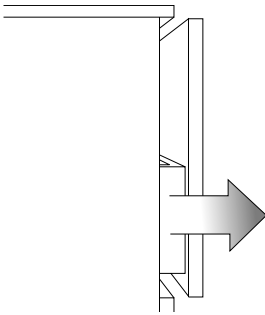
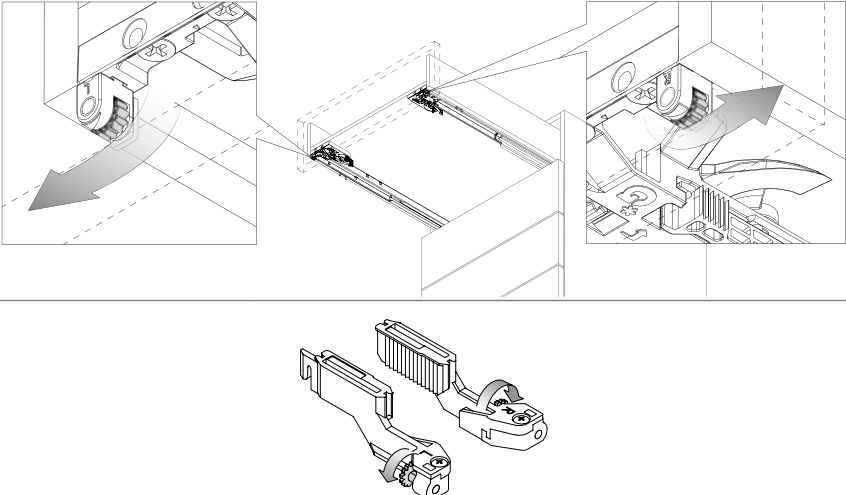
| | | | |
|---|--|--|---|
| <p>Height adjustment (max. +3.5 mm)</p>  | <p>Dynapro 3D/4D</p>  | | <p>Dynapro 2D</p>  |
| <p>Front tilt angle adjustment (max. +4.0 mm)</p>  | <p>Dynapro 2D/3D/4D</p>  | | |
| <p>Side adjustment (max. ±1.5 mm)</p>  | <p>Dynapro 3D/4D</p>  | |  |
| <p>Depth adjustment (max. +3.5 mm)</p>  | <p>Dynapro 3D/4D</p>  | | |

- 1
- 2
- 3
- 4
- 5
- 6
- 7
- 8



DYNAPRO

Technical information

DYNAPRO TIPMATIC SOFT-CLOSE

Front gap adjustment (+3 mm/-1 mm)

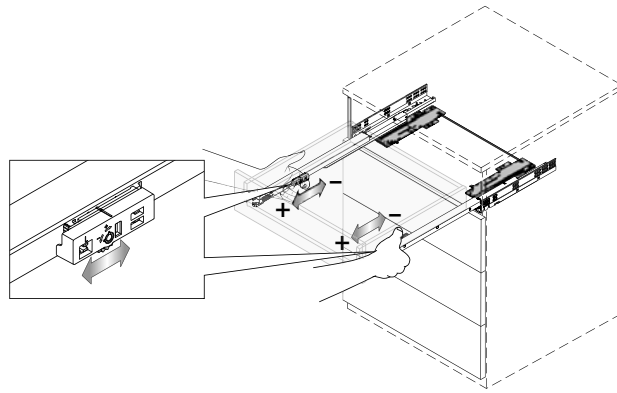
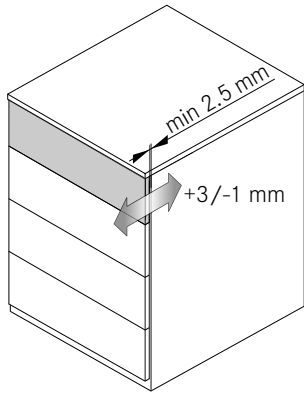

Opening force

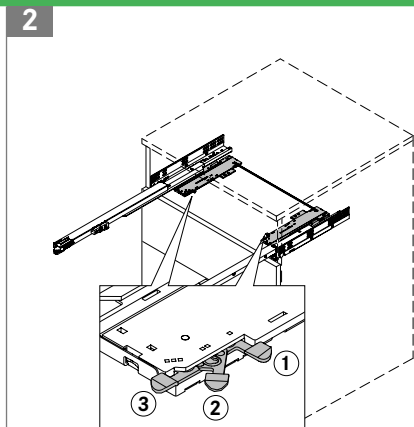
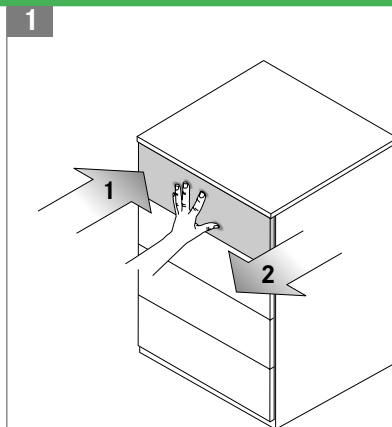
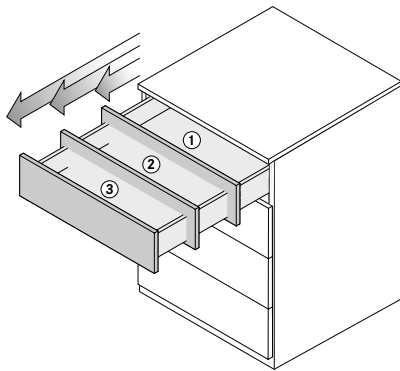

Activation zone

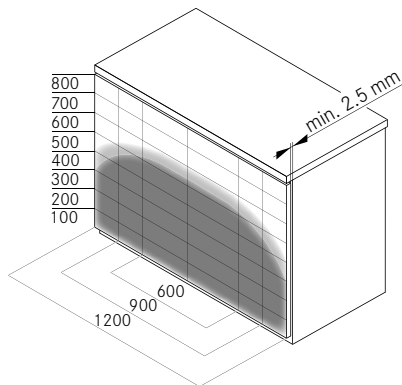

PAGE REFERENCES

| | | | | | |
|-----------------------------|-----|----------------------|-----|---------------|-----|
| Dynapro Soft-close | 536 | Pull-out shelf | 544 | Assembly aids | 668 |
| Dynapro Tipmatic Soft-close | 540 | Application examples | 546 | | |
| Dynapro Tipmatic | 542 | Sensomatic | 617 | | |

DYNAPRO TIPMATIC

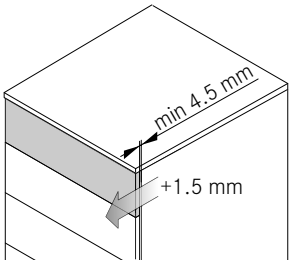
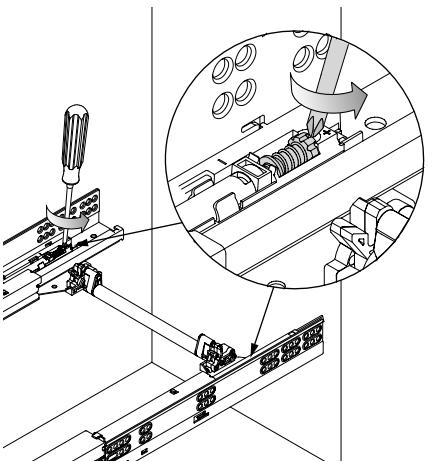
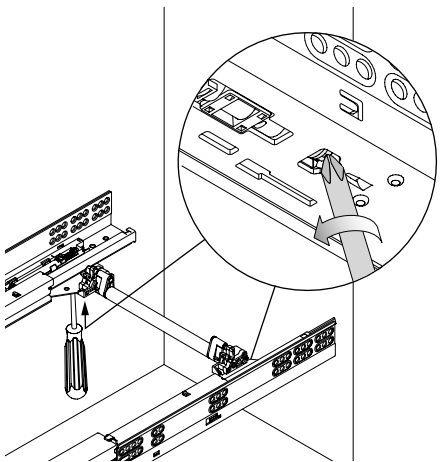
| Front gap adjustment (max. +1.5 mm) | Front gap adjustment from above | Front gap adjustment from below |
|---|--|---|
| <p>The reliable opening and closing of the drawer depends on the front gap setting (min. 4.5 mm = factory setting). If the front height is greater than 300 mm, the front gap must be increased to the maximum of 6 mm.</p>  |  |  |

2D ADJUSTMENT ADAPTER WITH TILT ANGLE AND SIDE ADJUSTMENT

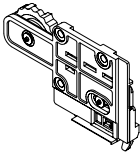
| | | Art. No. | |
|---|---|--------------------------|--|
| <ul style="list-style-type: none"> • Adjustment adapter for increased demands on the front gap, e.g. for extra-wide drawers • Integrated vertical tilt angle adjustment (+ 4 mm) and additional side adjustment (± 2.5 mm) • If necessary, this replaces the right-hand standard adjustment adapter |  | <p>F134100635</p> | |

LEGEND

